

# CHAMPION

GLOBAL POWER EQUIPMENT

TM-MC

OWNER'S MANUAL & OPERATING INSTRUCTIONS



6250 Starting Watts / 5000 Running Watts  
Recoil Start

## PORTABLE GENERATOR



MODEL NUMBER

100496

SAVE THESE INSTRUCTIONS  
Important Safety Instructions  
are included in this manual.

REV 100496-20210608

12039 Smith Ave.  
Santa Fe Springs CA 90670  
USA / 1-877-338-0999  
[www.championpowerequipment.com](http://www.championpowerequipment.com)

**AN IMPORTANT MESSAGE ABOUT TEMPERATURE:**

Your Champion Power Equipment product is designed and rated for continuous operation at ambient temperatures up to 40°C (104°F). When your product is needed your product may be operated at temperatures ranging from -15°C (5°F) to 50°C (122°F) for short periods. If the product is exposed to temperatures outside this range during storage, it should be brought back within this range before operation. In any event, the product must always be operated outdoors, in a well-ventilated area and away from doors, windows and other vents.

**Have questions or need assistance?**

Do not return this product to the store!

**WE ARE HERE TO HELP!**

Visit our website:

**[www.championpowerequipment.com](http://www.championpowerequipment.com)**

for more info:

- Product Info & Updates
- Tech Bulletins
- Frequently Asked Questions
- Product Registration

– or –

Call our Customer Care Team Toll-Free at:

**1-877-338-0999**

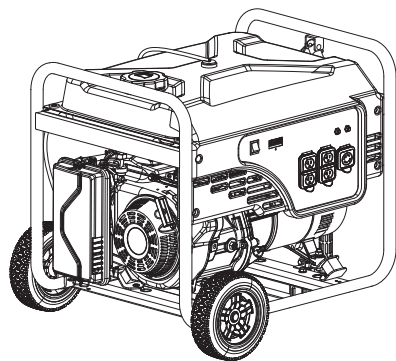

6250 Starting Watts / 5000 Running Watts  
Recoil Start

# PORTABLE GENERATOR

## TABLE OF CONTENTS

<b>Introduction</b> . . . . .	<b>1</b>	<b>Maintenance and Storage</b> . . . . .	<b>13</b>
<b>Manual Conventions</b> . . . . .	<b>2</b>	Engine Maintenance . . . . .	13
<b>Safety Rules</b> . . . . .	<b>3</b>	Oil . . . . .	13
<b>Controls and Features</b> . . . . .	<b>5</b>	Spark Plugs . . . . .	14
Generator . . . . .	5	Air Filter . . . . .	14
Power Panel . . . . .	6	Spark Arrester . . . . .	14
Parts Included . . . . .	7	Cleaning . . . . .	14
Wheel Kit . . . . .	7	Adjustments . . . . .	15
Other . . . . .	7	Maintenance Schedule . . . . .	15
<b>Assembly</b> . . . . .	<b>8</b>	Generator Maintenance . . . . .	15
Remove the Generator from the Shipping Carton . . . . .	8	Storage . . . . .	15
Install the Wheel Kit . . . . .	8	Generator Storage . . . . .	15
Install the Support Leg . . . . .	8	<b>Specifications</b> . . . . .	<b>17</b>
Install the Handle . . . . .	8	Engine Specifications . . . . .	17
Add Engine Oil . . . . .	9	Generator Specifications . . . . .	17
Add Fuel . . . . .	10	Fuel . . . . .	17
Grounding . . . . .	10	Oil . . . . .	17
<b>Operation</b> . . . . .	<b>11</b>	Spark Plugs . . . . .	17
Generator Location . . . . .	11	Maintenance Valve Clearance . . . . .	17
Surge Protection . . . . .	11	An Important Message About Temperature . . . . .	17
Starting the Engine . . . . .	11	Wiring Diagram . . . . .	18
Connecting Electrical Loads . . . . .	12	Parts Diagram . . . . .	19
Stopping the Engine . . . . .	12	Parts List . . . . .	20
Grounding . . . . .	12	Engine Parts Diagram . . . . .	21
Do Not Overload Generator . . . . .	12	Engine Parts List . . . . .	22
Capacity . . . . .	12	<b>Troubleshooting</b> . . . . .	<b>23</b>
Power Management . . . . .	12		
Operation at High Altitude . . . . .	13		

# INTRODUCTION

## Introduction

Congratulations on your purchase of a Champion Power Equipment product. Champion Power Equipment and Champion Engine Technology designs, builds, and supports all of our products to strict specifications and guidelines. With proper product knowledge, safe use, and regular maintenance, this product should bring years of satisfying service.

Every effort has been made to ensure the accuracy and completeness of the information in this manual, and we reserve the right to change, alter and/or improve the product and this document at any time without prior notice.

Since CPE/CET highly value how our products are designed, manufactured, operated and are serviced, and also highly value your safety and the safety of others, we would like you to take the time to review this product manual and other product materials thoroughly and be fully aware and knowledgeable of the assembly, operation, dangers and maintenance of the product before use. Fully familiarize yourself, and make sure others who plan on operating the product fully familiarize themselves too, with the proper safety and operation procedures before each use. Please always exercise common sense and always err on the side of caution when operating the product to ensure no accidents, property damage, or injury occurs. We want you to continue to use and be satisfied with your CPE/CET product for years to come.

Record the model and serial numbers as well as date and place of purchase for future reference. Have this information available when ordering parts and when making technical or warranty inquiries.

<b>Champion Power Equipment Support</b>	
<b>1-877-338-0999</b>	
Model Number	
<b>100496</b>	
Serial Number	
Date of Purchase	
Purchase Location	
<small>For <b>Oil Type</b> see 'Add Engine Oil' section. For <b>Fuel Type</b> see 'Add Fuel' section.</small>	

This manual uses the following symbols to help differentiate between different kinds of information. The safety symbol is used with a key word to alert you to potential hazards in operating and owning power equipment.

Follow all safety messages to avoid or reduce the risk of serious injury or death.

 **DANGER**

DANGER indicates an imminently hazardous situation which, if not avoided, **will** result in death or serious injury.

 **WARNING**

WARNING indicates a potentially hazardous situation which, if not avoided, **could** result in death or serious injury.

 **CAUTION**

CAUTION indicates a potentially hazardous situation which, if not avoided, **may** result in minor or moderate injury.

**CAUTION**

CAUTION used without the safety alert symbol indicates a potentially hazardous situation which, if not avoided, **may** result in property damage.

 **NOTE**

If you have questions regarding your generator, we can help. Please call our help line at **1-877-338-0999**

# SAFETY RULES

## WARNING

Read this manual thoroughly before operating your generator. Failure to follow instructions could result in serious injury or death.

## DANGER

Generator exhaust contains carbon monoxide, a colorless, odorless, poison gas. Breathing carbon monoxide will cause nausea, dizziness, fainting or death. If you start to feel dizzy or weak, get to fresh air immediately.

Operate generator outdoors only in a well ventilated area.

DO NOT operate the generator inside any building, including garages, basements, crawlspaces and sheds, enclosure or compartment, including the generator compartment of a recreational vehicle. DO NOT allow exhaust fumes to enter a confined area through windows, doors, vents or other openings.

**DANGER CARBON MONOXIDE:** using a generator indoors **CAN KILL YOU IN MINUTES.**

## DANGER

Rotating parts can entangle hands, feet, hair, clothing and/or accessories.  
Traumatic amputation or severe laceration can result.

Keep hands and feet away from rotating parts.  
Tie up long hair and remove jewelry.  
Operate equipment with guards in place.  
DO NOT wear loose-fitting clothing, dangling drawstrings or items that could become caught.

## WARNING

Operation of this equipment may create sparks that can start fires around dry vegetation.

A spark arrestor may be required. The operator should contact local fire agencies for laws or regulations relating to fire prevention requirements.

## DANGER

Generator produces powerful voltage.

DO NOT touch bare wires or receptacles.  
DO NOT use electrical cords that are worn, damaged or frayed.  
DO NOT operate generator in wet weather.  
DO NOT allow children or unqualified persons to operate or service the generator  
Use a ground fault circuit interrupter (GFCI) in damp areas and areas containing conductive material such as metal decking.  
Use approved transfer equipment to isolate generator from your electric utility and Notify your utility company before connecting your generator to your power system.

## WARNING

Sparks can result in fire or electrical shock.

### When servicing the generator:

Disconnect the spark plug wire and place it where it cannot contact the plug.  
DO NOT check for spark with the plug removed.  
Use only approved spark plug testers.

## WARNING

Running engines produce heat. Severe burns can occur on contact.  
Combustible material can catch fire on contact.

DO NOT touch hot surfaces.  
Avoid contact with hot exhaust gases.  
Allow equipment to cool before touching.  
Maintain at least 3 ft. (91.4 cm) of clearance on all sides to ensure adequate cooling.  
Maintain at least 5 ft. (1.5 m) of clearance from combustible materials.

## WARNING

Medical and Life Support Uses.

In case of emergency, call 911 immediately.  
NEVER use this product to power life support devices or life support appliances.  
NEVER use this product to power medical devices or medical appliances.  
Inform your electricity provider immediately if you or anyone in your household depends on electrical equipment to live.  
Inform your electrical provider immediately if a loss of power would cause you or anyone in your household to experience a medical emergency.

**⚠ DANGER**

Fuel and fuel vapors are highly flammable and extremely explosive.  
Fire or explosion can cause severe burns or death.  
Unintentional startup can result in entanglement, traumatic amputation or laceration.

**When adding or removing fuel:**

Turn the generator off and let it cool for at least two minutes before removing the fuel cap. Loosen the cap slowly to relieve pressure in the tank.  
Only fill or drain fuel outdoors in a well-ventilated area.  
DO NOT pump gas directly into the generator at the gas station. Use an approved container to transfer the fuel to the generator.  
DO NOT overfill the fuel tank.  
Always keep fuel away from sparks, open flames, pilot lights, heat and other sources of ignition.  
DO NOT light or smoke cigarettes.

**When starting the generator:**

DO NOT attempt to start a damaged generator.  
Make certain that the gas cap, air filter, spark plug, fuel lines and exhaust system are properly in place.  
Allow spilled fuel to evaporate fully before attempting to start the engine.  
Make certain that the generator is resting firmly on level ground.

**When operating the generator:**

DO NOT move or tip the generator during operation.  
DO NOT tip the generator or allow fuel or oil to spill.

**When transporting or servicing the generator:**

Make certain that the fuel shutoff valve is in the off position and the fuel tank is empty.  
Disconnect the spark plug wire.

**When storing the generator:**

Store away from sparks, open flames, pilot lights, heat and other sources of ignition.

**⚠ WARNING**

Cancer and Reproductive Harm –  
[www.P65Warnings.ca.gov](http://www.P65Warnings.ca.gov)

**⚠ WARNING**

Rapid retraction of the starter cord will pull hand and arm towards the engine faster than you can let go.  
Unintentional startup can result in entanglement, traumatic amputation or laceration.  
Broken bones, fractures, bruises or sprains could result.

When starting engine, pull the starter cord slowly until resistance is felt and then pull rapidly to avoid kickback.  
DO NOT start or stop the engine with electrical devices plugged in.

**⚠ CAUTION**

Exceeding the generator's running capacity can damage the generator and/or electrical devices connected to it.

DO NOT overload the generator.  
Start the generator and allow the engine to stabilize before connecting electrical loads.  
Connect electrical equipment in the off position, and then turn them on for operation.  
Turn electrical equipment off before stopping the generator.  
DO NOT tamper with the governed speed.  
DO NOT modify the generator in any way.

**⚠ CAUTION**

Improper treatment or use of the generator can damage it, shorten its life and void your warranty.

Use the generator only for intended uses.  
Operate only on level surfaces.  
DO NOT expose generator to excessive moisture, dust, or dirt.  
DO NOT allow any material to block the cooling slots.  
If connected devices overheat, turn them off and disconnect them from the generator.  
DO NOT use the generator if:

- Electrical output is lost
- Equipment sparks, smokes or emits flames
- Equipment vibrates excessively

# CONTROLS AND FEATURES

Read this owner's manual before operating your generator. Familiarize yourself with the location and function of the controls and features. Save this manual for future reference.

## Generator

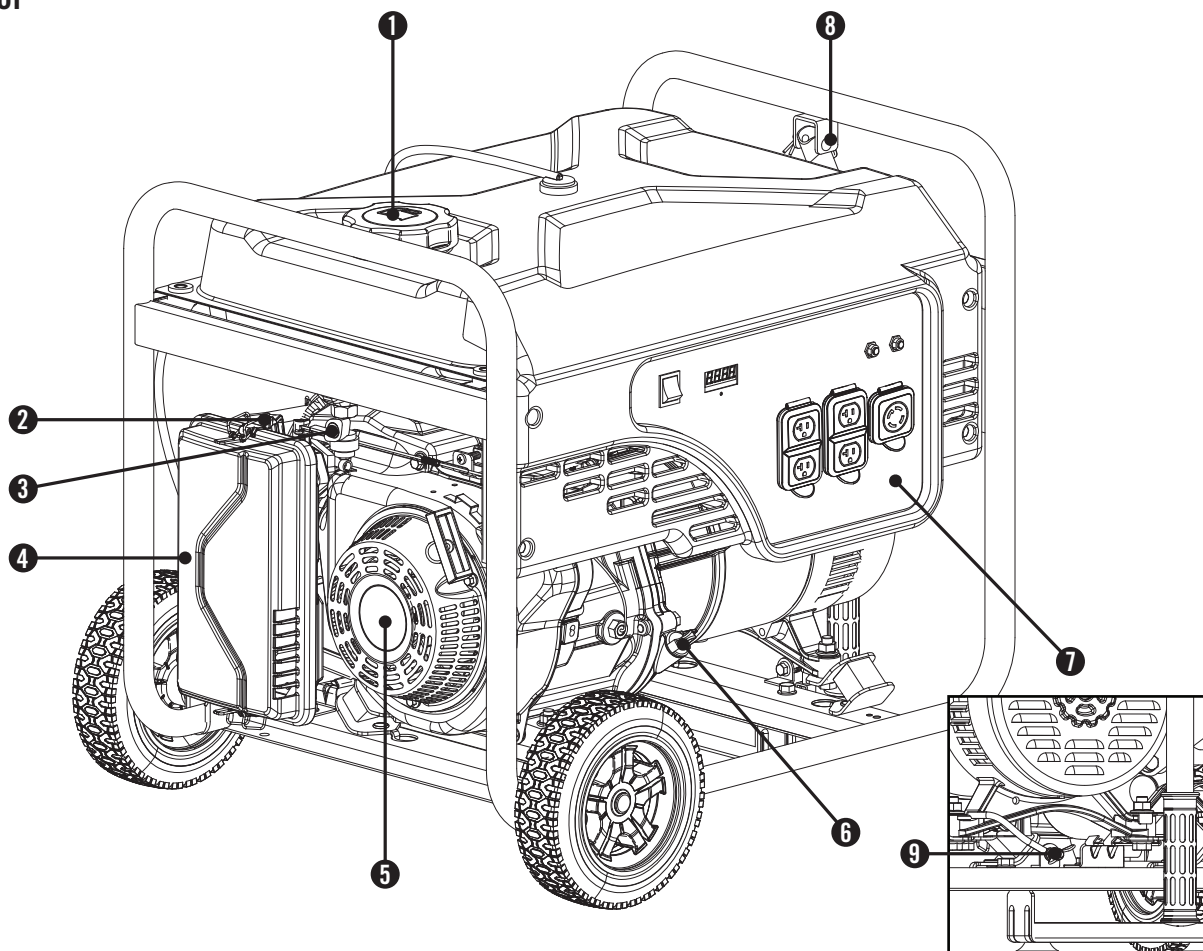

- |   |  |
|---|--|
| (1) <b>Fuel Tank</b> – 5.7 gallon (21.5 L) capacity fuel tank.                                | (5) <b>Recoil Starter</b> – Used to start the engine.                                |
| (2) <b>Choke</b> – Used to start the engine.  | (6) <b>Oil Filler Cap</b> – Check and fill engine oil level.                         |
| (3) <b>Fuel Valve</b> – Turn this valve to the “ON” position to supply fuel to the engine.    | (7) <b>Power Panel</b> – See “Power Panel” section.                                  |
| (4) <b>Air Filter</b> – Protects the engine by filtering dust and debris from the intake air. | (8) <b>Handle</b>  |
|   | (9) <b>Ground Terminal</b> – Consult an electrician for local grounding regulations. |



## Power Panel

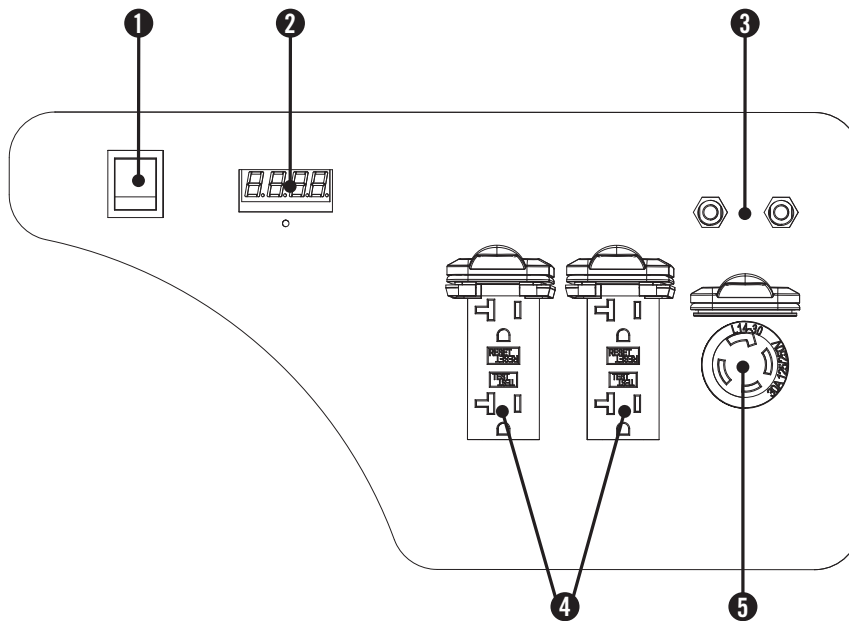

- (1) **Engine Switch** – Used to turn the generator on and off.
- (2) **Intelligauge** – Three mode digital meter for displaying running hours, voltage and hertz.
- (3) **Circuit Breakers** – Protects the generator against electrical overloads. Push to reset breaker.
- (4) **120 Volt AC, 20 Amp Duplex (2) (GFCI 5-20R)** – May be used to supply electrical power for the operation of 120 Volt AC single phase 60 Hz electrical loads.
- (5) **120/240 Volt AC, 30 Amp Twist-Lock Receptacle (NEMA L14-30R)** – May be used to supply electrical power for the operation of 120/240 Volt AC, single phase 60 Hz electrical loads.

# CONTROLS AND FEATURES

## Parts Included

Your 100496 Gasoline Powered Generator ships with the following parts:

### Wheel Kit

- 8 in. Wheel . . . . . 2
- Pin Roll (Ø16x90 for Wheel) . . . . . 2
- R-Pin . . . . . 2
- Handle . . . . . 1
- Support Leg w/Vibration Mounts . . . . . 1
- Flange Bolt (M8x16 for Support Leg) . . . . . 2
- Nut (M8) . . . . . 2
- Pin Roll (Ø8x40 for Handle) . . . . . 1
- R-Pin (R5 for Handle) . . . . . 1

### Other

- Oil . . . . . 1.2 qt. (1.1 L)
- Oil Funnel . . . . . 1

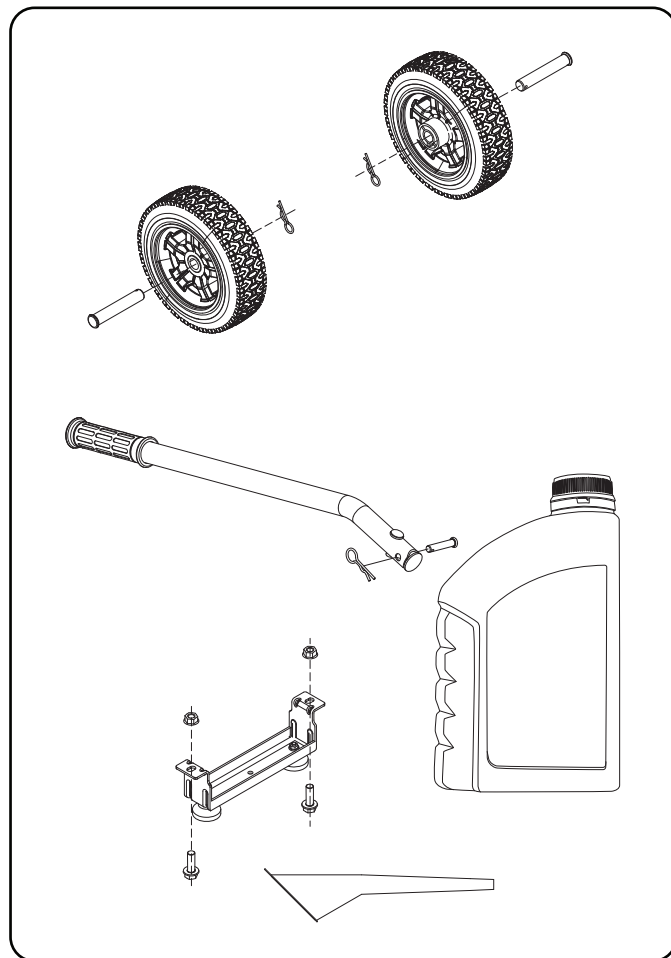

Your generator requires some assembly. This unit ships from our factory without oil. It must be properly serviced with fuel and oil before operation.

If you have any questions regarding the assembly of your generator, call our help line at 1-877-338-0999. Please have your serial number and model number available.

## Remove the Generator from the Shipping Carton

1. Set the shipping carton on a solid, flat surface.
2. Remove everything from the carton except the generator.
3. Carefully cut each corner of the box from top to bottom. Fold each side flat on the ground to provide a surface area to install the wheel kit and support leg.

## Install the Wheel Kit

### ! CAUTION

The wheel kit is not intended for over-the-road use.

1. Before adding fuel and oil, tip the generator on it's side.
2. Slide the wheel pin roll (#12) through the wheel (#13) from the outside.
3. Slide the pin roll through the mount point on the frame.
4. Secure the R-Pin (#14).
5. Repeat steps 2-4 to attach the second wheel.

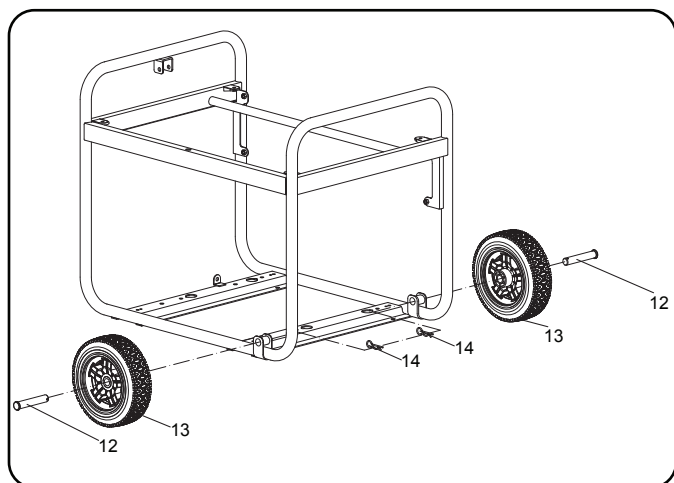

## Install the Support Leg

1. Align the Support Foot (#36) with the holes on the frame.
2. Insert an M8x16 flange bolt (#41) through each hole from the bottom.
3. Secure each bolt with an M8 nut (#35) from the top.

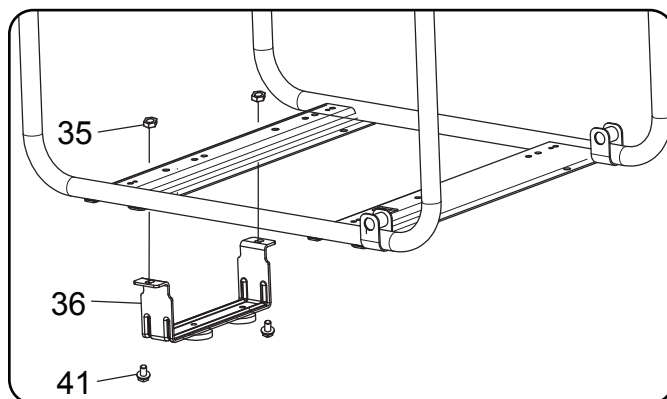

## Install the Handle

1. Place the Handle inside the mounting channel on the frame.
2. Secure the Handle to the frame using a Pin Roll (25).
3. Place an R-Pin (26) on the end of the Pin Roll and fasten securely.

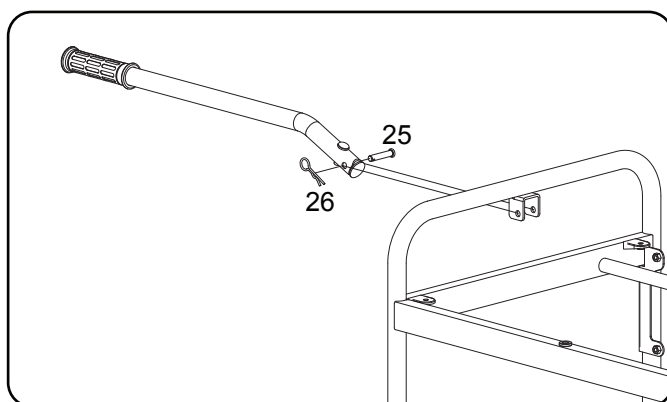

# ASSEMBLY

## Add Engine Oil

### ! CAUTION

DO NOT attempt to crank or start the engine before it has been properly filled with the recommended type and amount of oil. Damage to the generator as a result of failure to follow these instructions will void your warranty.

### NOTE

The generator rotor has a sealed, pre-lubricated ball bearing that requires no additional lubrication for the life of the bearing.

### NOTE

The recommended oil type is 10W-30 automotive oil.

1. Place the generator on a flat, level surface.

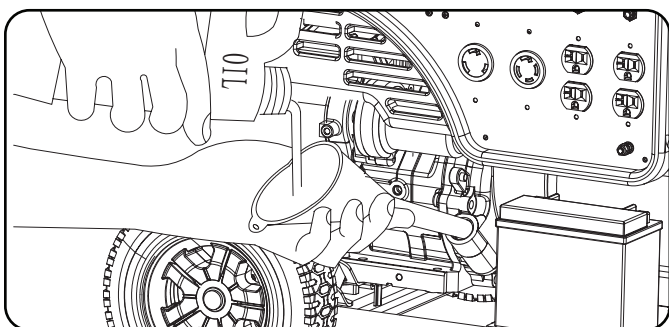

2. Remove oil fill cap/dipstick to add oil.
3. Add up to 1.2 qt. (1.1 L) of oil (included) and replace oil fill cap/dipstick. DO NOT OVERFILL.
4. Check engine oil level daily and add as needed.

### NOTE

Once oil has been added, a visual check should show oil about 1-2 threads from running out of the fill hole. If using the dipstick to check oil level, DO NOT screw in the dipstick while checking.

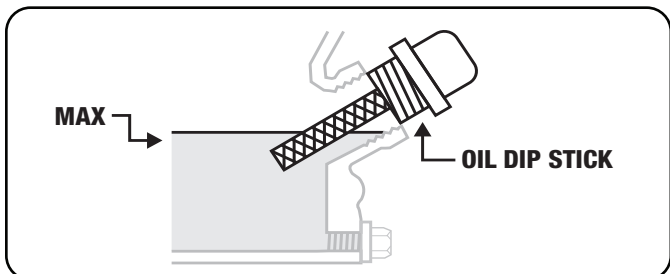

## Add Engine Oil Cont'd.

### NOTE

Check oil often during the break-in period. Refer to the Maintenance section for recommended service intervals.

### CAUTION

The engine is equipped with a low oil shut-off and will stop when the oil level in the crankcase falls below the threshold level.

### NOTE

We consider the first 5 hours of run time to be the break-in period for the unit. During the break in period stay at or below 50% of the running watt rating and vary the load occasionally to allow stator windings to heat and cool. Adjusting the load will also cause engine speed to vary and help seat piston rings. After the 5 hour break-in period, change the oil.

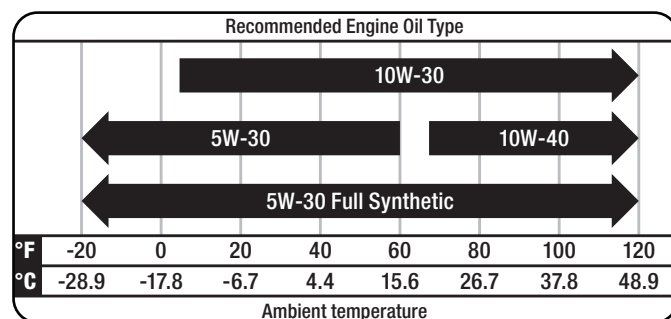

### NOTE

Weather will affect engine oil and engine performance. Change the type of engine oil used based on weather conditions to suit the engine needs.

### NOTE

Synthetic oil may be used after the 5 hour initial break-in period. Using synthetic oil does not increase the recommended oil change interval.

## Add Fuel

1. Use clean, fresh, regular unleaded fuel with a minimum octane rating of 87 and an ethanol content of less than 10% by volume.
2. DO NOT mix oil with fuel.
3. Clean the area around the fuel cap.
4. Remove the fuel cap.
5. Slowly add fuel to the tank. DO NOT OVERFILL. Fuel can expand after filling. A minimum of  $\frac{1}{4}$  in. (6.4 mm) of space left in the tank is required for fuel expansion, more than  $\frac{1}{4}$  in. (6.4 mm) is recommended. Fuel can be forced out of the tank as a result of expansion if it is overfilled, and can affect the stable running condition of the product. When filling the tank, it is recommended to leave enough space for the fuel to expand.

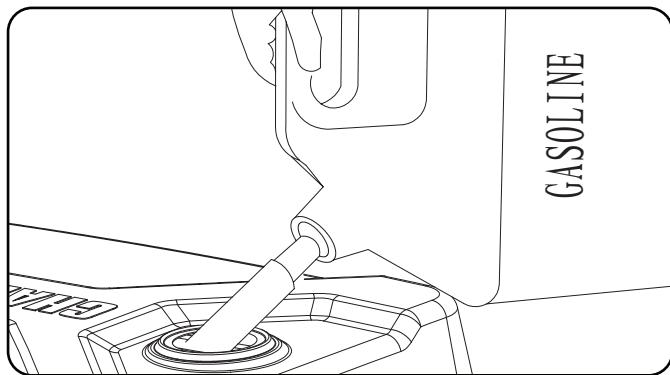

6. Screw on the fuel cap and wipe away any spilled fuel.

### ⚠ CAUTION

Use regular unleaded gasoline with a minimum octane rating of 87.

Do not mix oil and gasoline.  
 Fill tank to approximately  $\frac{1}{4}$  in. (6.4 mm) below the top of the tank to allow for fuel expansion.  
 DO NOT pump gas directly into the generator at the gas station. Use an approved container to transfer the fuel to the generator.  
 DO NOT fill fuel tank indoors.  
 DO NOT fill fuel tank when the engine is running or hot.  
 DO NOT overfill the fuel tank.  
 DO NOT light cigarettes or smoke when filling the fuel tank.

### ⚠ WARNING

Pouring fuel too fast through the fuel screen may result in blow back of fuel at the operator while filling.

## Add Fuel Cont'd.

### NOTE

Our engines work well with 10% or less ethanol blend fuels. When using blended fuels there are some issues worth noting:

- Ethanol-gasoline blends can absorb more water than gasoline alone.
- These blends can eventually separate, leaving water or a watery goo in the tank, fuel valve and carburetor.
- With gravity-fed fuel supplies, this compromised fuel can be drawn into the carburetor and cause damage to the engine and/or potential hazards.
- There are only a few suppliers of fuel stabilizer that are formulated to work with ethanol blend fuels.
- Any damages or hazards caused by using improper fuel, improperly stored fuel, and/or improperly formulated stabilizers, are not covered by manufacture's warranty.

It is advisable to always shut off the fuel supply, run the engine to fuel starvation and drain the tank when the equipment is not in use for more than 30 days.

## Grounding

Your generator must be properly connected to an appropriate ground to help prevent electric shock.

### ⚠ WARNING

Failure to properly ground the generator can result in electric shock.

A ground terminal connected to the frame of the generator has been provided on the power panel. For remote grounding, connect of a length of heavy gauge (12 AWG minimum) copper wire between the generator ground terminal and a copper rod driven into the ground. We strongly recommend that you consult with a qualified electrician to ensure compliance with local electrical codes.

# OPERATION

## Generator Location

NEVER operate the generator inside any building, including garages, basements, crawlspaces and sheds, enclosure or compartment, including the generator compartment of a recreational vehicle. Please consult your local authority. In some areas, generators must be registered with the local utility. Generators used at construction sites may be subject to additional rules and regulations. Generators should be on a flat, level surface at all times. (Even while not in operation) Generators must have at least 5 ft. (1.5 m) of clearance from all combustible material. In addition to clearance from all combustible material, generators must also have at least 3 ft. (91.4 cm) of clearance on all sides to allow for adequate cooling, maintenance and servicing. Generators should never be started or operated in the back of a SUV, camper, trailer, in the bed of a truck (regular, flat or otherwise), under staircases/stairwells, next to walls or buildings, or in any other location that will not allow for adequate cooling of the generator and/or the muffler. DO NOT contain generators during operation. Allow generators to properly cool before transport or storage.

Place the generator in a well-ventilated area. DO NOT place the generator near vents or intakes where exhaust fumes could be drawn into occupied or confined spaces. Carefully consider wind and air currents when positioning generator.

**Failure to follow proper safety precautions may void manufacturer's warranty.**

### WARNING

Do not operate or store the generator in rain, snow, or wet weather.

Using a generator or electrical appliance in wet conditions, such as rain or snow, or near a pool or sprinkler system, or when your hands are wet, could result in electrocution.

### WARNING

During operation the muffler and exhaust fumes produced will become hot. If adequate cooling and breathing space are not supplied, or if the generator is blocked or contained, temperatures can become extremely heated and may lead to fire.

## Surge Protection

### CAUTION

Voltage fluctuation may impair the proper functioning of sensitive electronic equipment.

Electronic devices, including computers and many programmable appliances use components that are designed to operate within a narrow voltage range and may be affected by momentary voltage fluctuations. While there is no way to prevent voltage fluctuations, you can take steps to protect sensitive electronic equipment.

1. *Install UL1449, CSA-listed, plug-in surge suppressors on the outlets feeding your sensitive equipment.*  
Surge suppressors come in single- or multi-outlet styles. They're designed to protect against virtually all short-duration voltage fluctuations.

## Starting the Engine

1. Make certain the generator is on a flat, level surface.
2. Disconnect all electrical loads from the generator.  
Never start or stop the generator with electrical devices plugged in or turned on.
3. Turn the Fuel Valve to the "ON" position.
4. Flip the engine switch to the "ON" position.
5. Move the choke lever to the "CHOKE" position.
6. Pull the starter cord slowly until resistance is felt and then pull rapidly
7. Do not over-choke. As soon as engine starts, move the choke lever to the "RUN" position.

### NOTE

Keep choke lever in "Choke" position for only 1 pull of the recoil starter. After first pull, move choke lever to the "Run" position for up to the next 3 pulls of the recoil starter. Too much choke leads to sparkplug fouling/engine flooding due to the lack of incoming air. This will cause the engine not to start.

### NOTE

If the engine starts but does not run make certain that the generator is on a flat, level surface. The engine is equipped with a low oil sensor that will prevent the engine from running when the oil level falls below a critical threshold.

## Connecting Electrical Loads

1. Let the engine stabilize and warm up for a few minutes after starting
2. Plug in and turn on the desired 120/240 Volt AC single phase, 60 Hz electrical loads.
  - DO NOT connect 3-phase loads to the generator.
  - DO NOT connect 50 Hz loads to the generator.
  - DO NOT overload the generator.

### NOTE

Connecting a generator to your electric utility company's power lines or to another power source may be against the law. In addition this action, if done incorrectly, could damage your generator and appliances and could cause serious injury or even death to you or a utility worker who may be working on nearby power lines. If you plan to run a portable electric generator during an outage, please notify your electric utility company immediately and remember to plug your appliances directly into the generator. Do not plug the generator into any electric outlet in your home. Doing so could create a connection to the utility company power lines. You are responsible for ensuring that your generator's electricity does not feed back into the electric utility power lines.

If the generator will be connected to a building electrical system, consult your local utility company or a qualified electrician. Connections must isolate generator power from utility power and must comply with all applicable laws and codes.

## Stopping the Engine

1. Turn off and unplug all electrical loads. Never start or stop the generator with electrical devices plugged in or turned on.
2. Let the generator run at no-load for several minutes to stabilize internal temperatures of the engine and generator.
3. Turn the Fuel Valve to the "OFF" position.
4. Let the engine run until fuel starvation has stopped the engine. This usually takes a few minutes.
5. Press the engine switch to the "OFF" position.

**Important:** Always ensure that the Fuel Valve and the Engine Switch are in the "OFF" position when the engine is not in use.

### NOTE

If the engine will not be used for a period of two (2) weeks or longer, please see the Storage section for proper engine and fuel storage.

## Grounding

The generator system ground connects the frame to the ground terminals on the power panel. The system ground is connected to the AC neutral wire.

## Do Not Overload Generator

### Capacity

Follow these simple steps to calculate the running and starting watts necessary for your purposes.

1. Select the electrical devices you plan on running at the same time.
2. Total the running watts of these items. This is the amount of power you need to keep your items running.
3. Identify the highest starting wattage of all devices identified in step 1. Add this number to the number calculated in step 2. Surge wattage is the extra burst of power needed to start some electric driven equipment. Following the steps listed under "Power Management" will guarantee that only one device will be starting at a time.

### Power Management

Use the following formula to convert voltage and amperage to watts:

$$\text{Volts} \times \text{Amps} = \text{Watts}$$

To prolong the life of your generator and attached devices, follow these steps to add electrical load:

1. Start the generator with no electrical load attached
2. Allow the engine to run for several minutes to stabilize.
3. Plug in and turn on the first item. It is best to attach the item with the largest load first.
4. Allow the engine to stabilize.
5. Plug in and turn on the next item.
6. Allow the engine to stabilize.
7. Repeat steps 5-6 for each additional item.

### NOTE

Never exceed the specified capacity when adding loads to the generator.

# OPERATION

## OPERATION AT HIGH ALTITUDE

The density of air at high altitudes is lower than at sea level. Engine power is reduced as the air mass and air-fuel ratio decrease. Engine power and generator output will be reduced approximately 3½% for every 1000 ft. of elevation above sea level. At high altitudes increased exhaust emissions can also result due to the increased enrichment of the air fuel ratio. Other high altitude issues can include hard starting, increased fuel consumption and spark plug fouling.

To alleviate high altitude issues other than the natural power loss, CPE can provide a high altitude carburetor main jet. The alternative main jet and installation instructions can be obtained by contacting our Technical Support Team. Installation instructions are also available in the Technical Bulletin area of the CPE website.

The part number and recommended minimum altitude for the application of the high altitude carburetor main jet is listed in the following table.

In order to select the correct high altitude main jet it is necessary to identify the carburetor model. For this purpose, a code is stamped on the side of the carburetor. Select the correct high altitude jet part number corresponding to the carburetor code found on your particular carburetor.

Carb. Code	High Alt. Jet Part Number	Min. Altitude
Z910-2	100155680	3281 ft. (1000 m)
	100062832	6562 ft. (2000 m)

### WARNING

Operation using the alternative main jet at elevations lower than the recommended minimum altitude can damage the engine. For operation at lower elevations, the originally supplied standard main jet must be used. Operating the engine with the wrong engine configuration at a given altitude may increase its emissions and decrease fuel efficiency and performance.

## MAINTENANCE AND STORAGE

The owner/operator is responsible for all periodic maintenance.

### WARNING

Never operate a damaged or defective generator.

### WARNING

Tampering with the factory set governor will void your warranty.

### WARNING

Improper maintenance will void your warranty.

### NOTE

Maintenance, replacement, or repair of emission control devices and systems may be performed by any non-road engine repair establishment or individual.

Complete all scheduled maintenance in a timely manner. Correct any issue before operating the generator.

### NOTE

For service or parts assistance, contact our help line at **1-877-338-0999**

## Engine Maintenance

To prevent accidental starting, remove and ground spark plug wire before performing any service.

### Oil

Change oil when the engine is warm. Refer to the oil specification to select the proper grade of oil for your operating environment.

1. Remove the oil drain plug with a 12 mm socket and extension (not included).
2. Allow the oil to drain completely.
3. Replace the drain plug.
4. Remove oil fill cap/dipstick to add oil.
5. Add up to 1.2 qt. (1.1 L) of oil and replace oil fill cap/dipstick. **DO NOT OVERFILL.**
6. Dispose of used oil at an approved waste management facility.



## Oil Cont'd.

**NOTE**

Once oil has been added, a visual check should show oil about 1-2 threads from running out of the fill hole. If using the dipstick to check oil level, DO NOT screw in the dipstick while checking.

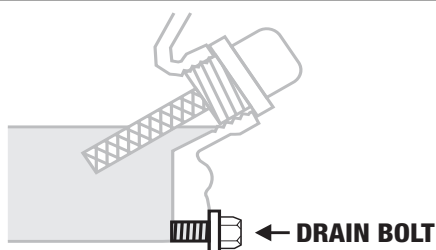

## Spark Plugs

1. Remove the spark plug cable from the spark plug.
2. Use the spark plug tool (not included) that shipped with your generator to remove the plug.
3. Inspect the electrode on the plug. It must be clean and not worn to produce the spark required for ignition.
4. Make certain the spark plug gap is 0.6 - 0.8 mm (0.024 - 0.031 in.).

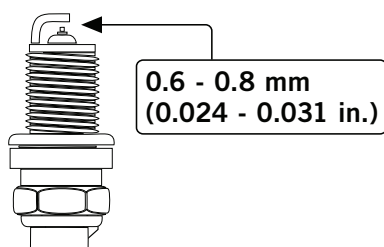

5. Refer to the spark plug recommendation chart when replacing the plug.
6. Carefully thread the plug into the engine.
7. Use the spark plug tool (not included) to firmly install the plug.
8. Attach the spark plug wire to the plug.

## Air Filter

1. Remove the snap-on cover holding the air filter to the assembly.
2. Remove the foam element.
3. Wash in liquid detergent and water. Squeeze thoroughly dry in a clean cloth.
4. Saturate in clean engine oil.
5. Squeeze in a clean, absorbent cloth to remove all excess oil.
6. Place the filter in the assembly.
7. Reattach the air filter cover and snap in place.

## Spark Arrester

1. Allow the engine to cool completely before servicing the spark arrester.
2. Remove the two screws holding the cover plate which retains the end of the spark arrester to the muffler.
3. Remove the spark arrester screen.
4. Carefully remove the carbon deposits from the spark arrester screen with a wire brush.
5. Replace the spark arrester if it is damaged.
6. Position the spark arrester in the muffler and attach with the two screws.

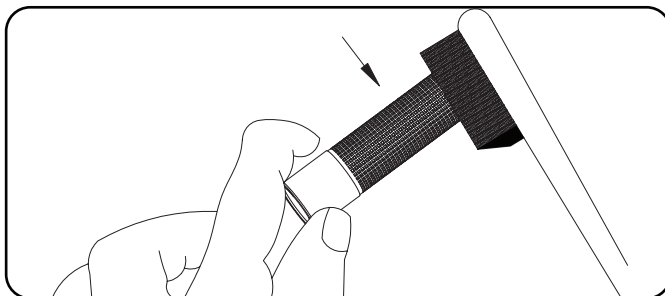
**CAUTION**

Failure to clean the spark arrester will result in degraded engine performance.

**NOTE**

Federal and local laws and administrative requirements indicate when and where spark arresters are required. When ordered, spark arresters are required for operation of this generator in National Forest lands. In California, this generator must not be used on any forest-covered land, brush-covered land, or grass-covered land unless the engine is equipped with a spark arrester.

## Cleaning

**CAUTION**

DO NOT spray engine with water.

Water can contaminate the fuel system.

Use a damp cloth to clean exterior surfaces of the engine. Use a soft bristle brush to remove dirt and oil. Use an air compressor (25 PSI) to clear dirt and debris from the engine.

# MAINTENANCE AND STORAGE

## Adjustments

The air-fuel mixture is not adjustable. Tampering with the governor can damage your generator and your electrical devices and will void your warranty. CPE recommends that you contact our service line at **1-877-338-0999** for all other service and/or adjustment needs.

## Maintenance Schedule

Follow the service intervals indicated in the following maintenance schedule.

Service your generator more frequently when operating in adverse conditions.

Contact our helpline at **1-877-338-0999** to locate the nearest Champion Power Equipment certified service dealer for your generator or engine maintenance needs.

Every 8 hours or daily	
	Check oil level
	Clean around air intake and muffler
First 5 Hours	
	Change oil
Every 50 hours or every season	
	Clean air filter
	Change oil if operating under heavy load or in hot environments
Every 100 hours or every season	
	Change oil
	Clean/Adjust spark plug
	Check/Adjust valve clearance*
	Clean spark arrester
	Clean fuel tank and filter*
Every 250 hours	
	Clean combustion chamber*
Every 3 years	
	Replace fuel line

\*To be performed by knowledgeable, experienced owners or Champion Power Equipment certified dealers.

## Generator Maintenance

Make certain that the generator is kept clean and stored properly. Only operate the unit on a flat, level surface in a clean, dry operating environment. DO NOT expose the unit to extreme conditions, excessive dust, dirt, moisture or corrosive vapors.

### ! CAUTION

**DO NOT** use a garden hose to clean the generator.

Water can enter the generator through the cooling slots and damage the generator windings.

Use a damp cloth to clean exterior surfaces of the generator. Use a soft bristle brush to remove dirt and oil. Use an air compressor (25 PSI) to clear dirt and debris from the generator. Inspect all air vents and cooling slots to ensure that they are clean and unobstructed.

## Storage

The generator should be started at least once every 14 days and allowed to run for at least 20 minutes. For longer term storage, please follow these guidelines.

### Generator Storage

1. Add a properly formulated fuel stabilizer to the tank.
2. Be sure all appliances are disconnected from the generator.
3. Run the generator for a few minutes so the treated fuel cycles through the fuel system and carburetor.
4. Turn the fuel valve to the "Off" position.
5. Let the generator run until fuel starvation has stopped the engine. This usually takes a few minutes.
6. The generator needs to cool completely before cleaning and storage.
7. Clean the generator according to the maintenance section.
8. Change the oil.
9. Remove the spark plug and pour about 1/2 ounce (14.8 mL) of oil into the cylinder. Crank the engine slowly to distribute the oil and lubricate the cylinder.
10. Reattach the spark plug.
11. Store the unit in a clean, dry place out of direct sunlight.

## Generator Storage Cont'd.

 **NOTE**

Our engines work well with 10% or less ethanol blend fuels. When using blended fuels there are some issues worth noting:

- Ethanol-gasoline blends can absorb more water than gasoline alone.
- These blends can eventually separate, leaving water or a watery goo in the tank, fuel valve and carburetor.
- With gravity-fed fuel supplies, this compromised fuel can be drawn into the carburetor and cause damage to the engine and/or potential hazards.
- There are only a few suppliers of fuel stabilizer that are formulated to work with ethanol blend fuels.
- Any damages or hazards caused by using improper fuel, improperly stored fuel, and/or improperly formulated stabilizers, are not covered by manufacture's warranty.

It is advisable to always shut off the fuel supply, run the engine to fuel starvation and drain the tank when the equipment is not in use for more than 30 days.

 **DANGER**

Generator exhaust contains odorless and colorless carbon monoxide gas.

To avoid accidental or unintended ignition of your generator during periods of storage, the following precautions should be followed:

- When **storing the generator for short or extended periods of time** make sure that the Engine Switch and the Fuel Valve are set in the **OFF** position.

# SPECIFICATIONS

## Engine Specifications

- Model . . . . . FH300
- Displacement . . . . . 292cc
- Type . . . . . 4-Stroke OHV
- Start Type . . . . . Recoil

## Generator Specifications

- Model . . . . . 100496
- Running Wattage . . . . . 5000 Watts
- Starting Wattage . . . . . 6250 Watts
- AC Load . . . . . 120/240 V
- Phase . . . . . Single
- Frequency . . . . . 60 Hz
- Fuel Capacity . . . . . 5.7 gallons (21.5 L)
- Gross Weight . . . . . 162 lb. (73.5 kg)
- Net Weight . . . . . 152.1 lb. (69 kg)
- Height . . . . . 25.2 in. (64 cm)
- Width . . . . . 25.7 in. (65.4 cm)
- Length . . . . . 30.1 in. (76.5 cm)

## Fuel

Fuel capacity is 5.7 gallons (21.5 L). Use regular unleaded gasoline with a minimum octane rating of 87 and an ethanol content of less than 10% by volume.

## Oil

Use 10W-30 automotive oil.

Oil capacity is up to 1.2 qt. (1.1 L).

**DO NOT OVERFILL.**

Please reference the following chart for recommended oil types for use in the generator.

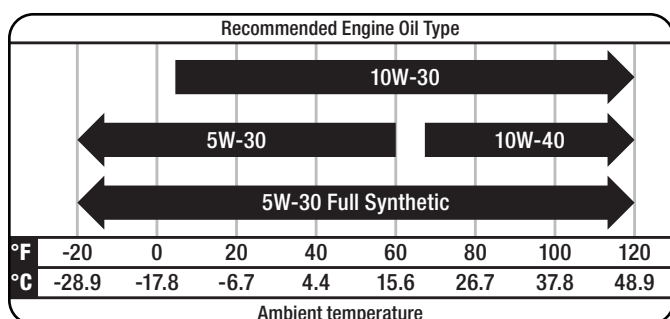

**NOTE**  
Weather will affect engine oil and engine performance. Change the type of engine oil used based on weather conditions to suit the engine needs.

## Spark Plugs

**OEM spark plug:** F6RTC

**Replacement spark plug:** NGK BPR6ES or equivalent  
Make certain the spark plug gap is 0.6 - 0.8 mm or (0.024 - 0.031 in.).

## Maintenance Valve Clearance

- Intake: 0.10 – 0.15 mm (0.004 – 0.006 in.)
  - Exhaust: 0.15 – 0.20 mm (0.006 – 0.008 in.)
- Note: Tech bulletin regarding the valve adjustment procedure is on [www.championpowerequipment.com](http://www.championpowerequipment.com).

## An Important Message About Temperature

Your Champion Power Equipment product is designed and rated for continuous operation at ambient temperatures up to 40°C (104°F). When your product is needed your product may be operated at temperatures ranging from -15°C (5°F) to 50°C (122°F) for short periods. If the product is exposed to temperatures outside this range during storage, it should be brought back within this range before operation. In any event, the product must always be operated outdoors, in a well-ventilated area and away from doors, windows and other vents.

Wiring Diagram

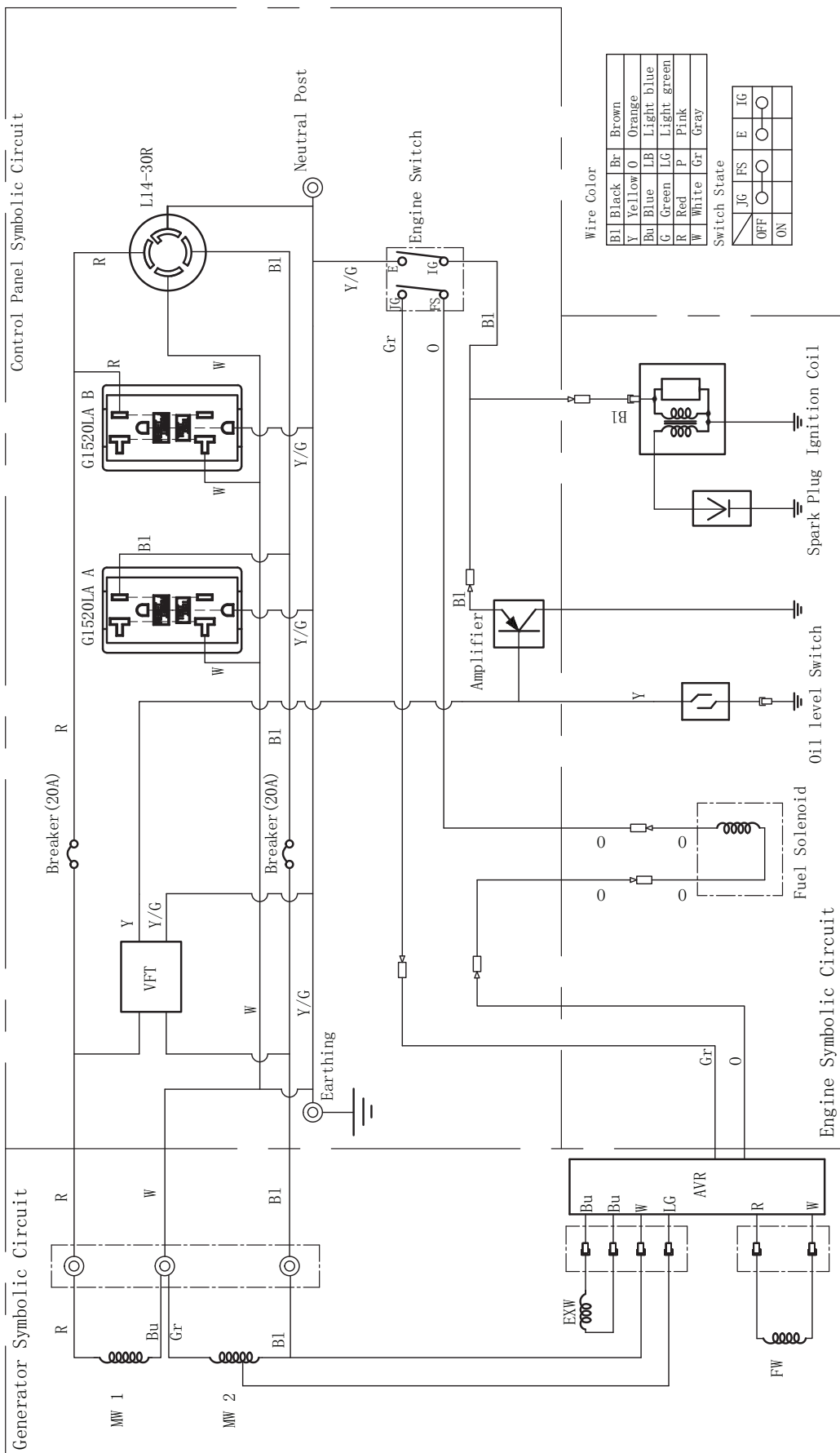

# SPECIFICATIONS

## Parts Diagram

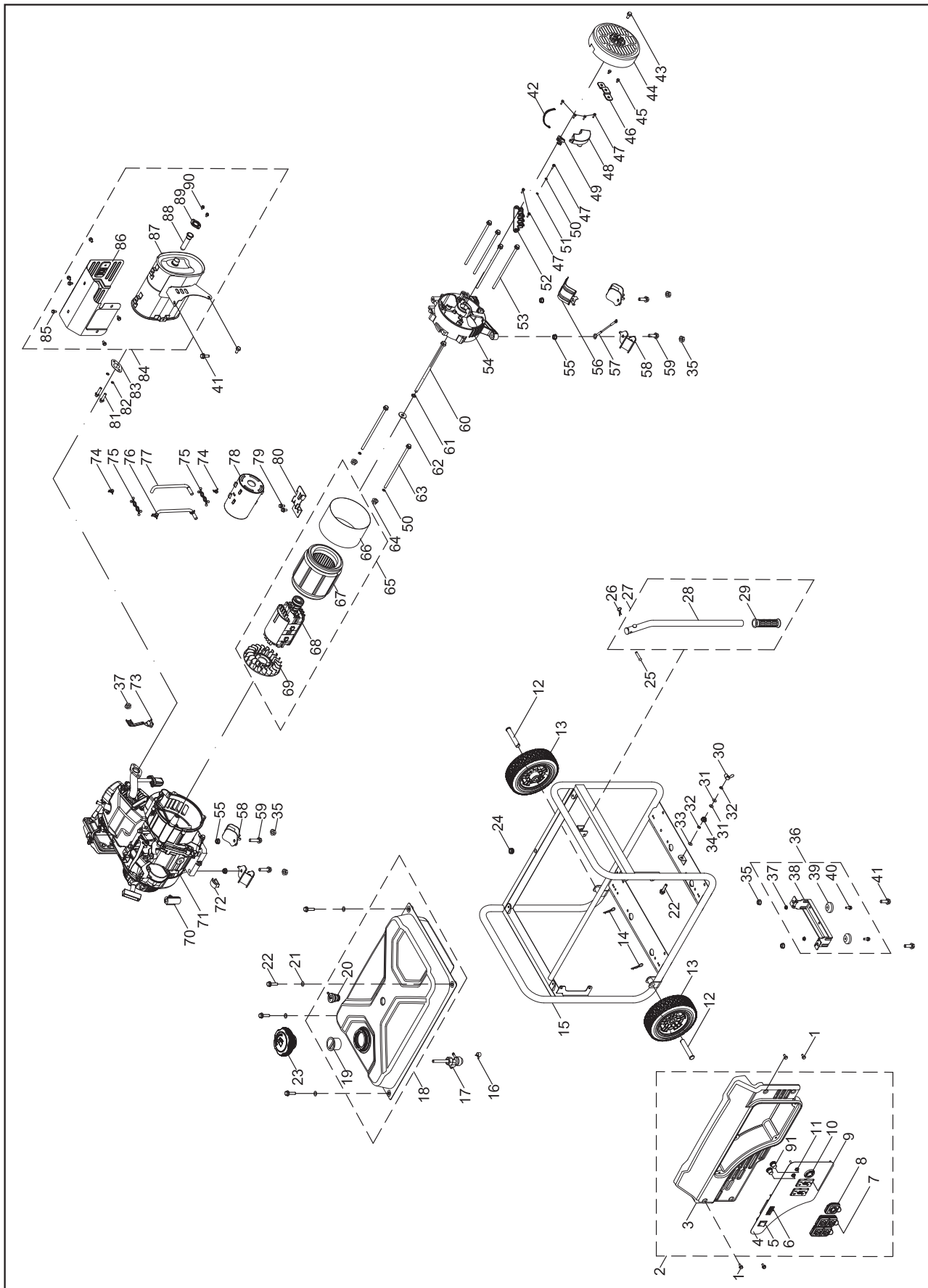

#	Part Number	Description	Qty
1	100011530-0002	Flange Bolt M6 x 16	4
2	100156472-0001	Panel Assembly	1
3	100019842	Protect Panel	1
4	100077161	Control Panel	1
5	100019772-0001	Switch	1
6	100019890	Intelligauge	1
7	100088270	Receptacle Cover GFCI 5-20R, Duplex	2
8	100088267	Receptacle Cover L14-30R	1
9	100052461-0001	Receptacle GFCI 5-20R, Duplex	2
10	100020021	Receptacle L14-30R	1
11	100019754	20Amp Circuit Breaker, Push Button	2
12	100123528-0001	Pin Roll Ø16 x 90	2
13	100020702-0001	8 In. Wheel	2
14	100023414-0001	R-pin	2
15	100077374-0001	Frame	1
16	100005138	Clamp Ø9.5 x 8	1
17	100021153	Fuel Valve	1
18	100136768-0001	Fuel Tank	1
19	100032382	Fuel Level Filter Assembly	1
20	100008968	Reversal Valve	1
21	100010439-0002	Washer Ø6.5 x 2 x Ø25	4
22	100011268-0003	Flange Bolt M6 x 25	5
23	100091755	Fuel Tank Cap	1
24	100009075	Rubber Damper	1
25	100011047-0003	Pin Roll Ø8 x 40	1
26	100714685-0001	R-pin, R5	1
27	100078539-0001	Handle Assembly	1
28	100078540-0001	Handle	1
29	100031982	Sheath, Handle	1
30	100010828-0002	Butterfly Type Nut M6	1
31	100010920-0002	Flat Washer Ø6	2
32	100010886-0004	Spring Washer Ø6	2
33	100011025-0001	Lock Washer Ø6, Toothed	1
34	100011421-0003	Flange Nut M6	1
35	100011453-0003	Lock Nut M8, Flange	6
36	100020978-0001	Support Leg Assembly	1
37	100011452-0003	Lock Nut M6, Flange	3
38	100020659-0001	Support Leg	1
39	100021015	Vibration Mount	2
40	100011265-0003	Flange Bolt M6 x 18	2
41	100011311-0005	Flange Bolt M8 x 16	4
42	100000563	Cable Ties, L=85 mm	1
43	100011570-0001	Big Flange Bolt M6 x 12	1
44	100018662-0001	Generator End Cover	1
45	100011250-0002	Flange Bolt M5 x 14	2

#	Part Number	Description	Qty
46	100020167	Support, End Cover	1
47	100011252-0001	Flange Bolt M5 x 18	7
48	100018611	AVR	1
49	100018595	Carbon Brush Assembly	1
50	100010885-0004	Spring Washer Ø5	3
51	100010919-0002	Flat Washer Ø5	1
52	100018701	Terminal Block	1
53	100011296-0001	Flange Bolt M6 x 160	4
54	100018572	End Housing	1
55	100011456-0003	Flange Nut M10 x 1.25	4
56	100021029	Protective Plate	1
57	100009983	Grounding Line 150 mm	1
58	100031984	Vibration Mount, Support	4
59	100011381-0002	Flange Bolt M10 x 1.25 x 40	4
60	100011393-0001	Flange Bolt M10 x 1.25 x 250	1
61	100010888-0002	Spring Washer Ø10	1
62	100010905-0001	Washer Ø10	1
63	100077436-0002	Flange Bolt M5 x 193	2
64	100018476	Flange Nut M5	2
65	100077191	Alternator Assembly	1
66	100077489	Stator Cover	1
67	100077486	Stator Assembly, Ø190 x 120 mm	1
68	100077487	Rotor Assembly	1
69	100018560	Cooling Fan	1
70	100000657	Cable Clamp	1
71	1ZC7DF0N6	Engine, 292 cc	1
72	100018704	Rubber Plug	1
73	100021036	Holder, Air Cleaner	1
74	100005148	Clamp 1	2
75	100000658	Clamp 2	2
76	100006128	Connection Tube Assembly 1	1
77	100077409	Connection Tube Assembly, 850mm	1
78	100008945	Carbon Canister 650 cc	1
79	100011261-0004	Flange Bolt M6 x 12	2
80	100008675-0001	Holder, Carbon Canister	1
81	100011553-0001	Flange Bolt M8 x 32	2
82	100010887-0004	Spring Washer Ø8	2
83	100006938	Gasket, Exhaust Pipe	1
84	100077372	Exhaust Muffler Assembly	1
85	100011260-0004	Flange Bolt M6 x 10	6
86	100006814	Muffler Cover	1
87	100006495	Muffler	1
88	100006594	Spark Arrester Assembly	1
89	100006999	Plate, Spark Arrester	1
90	100011247-0003	Flange Bolt M5 x 8	2
91	100120180	Breaker Cover	2

# SPECIFICATIONS

## Engine Parts Diagram

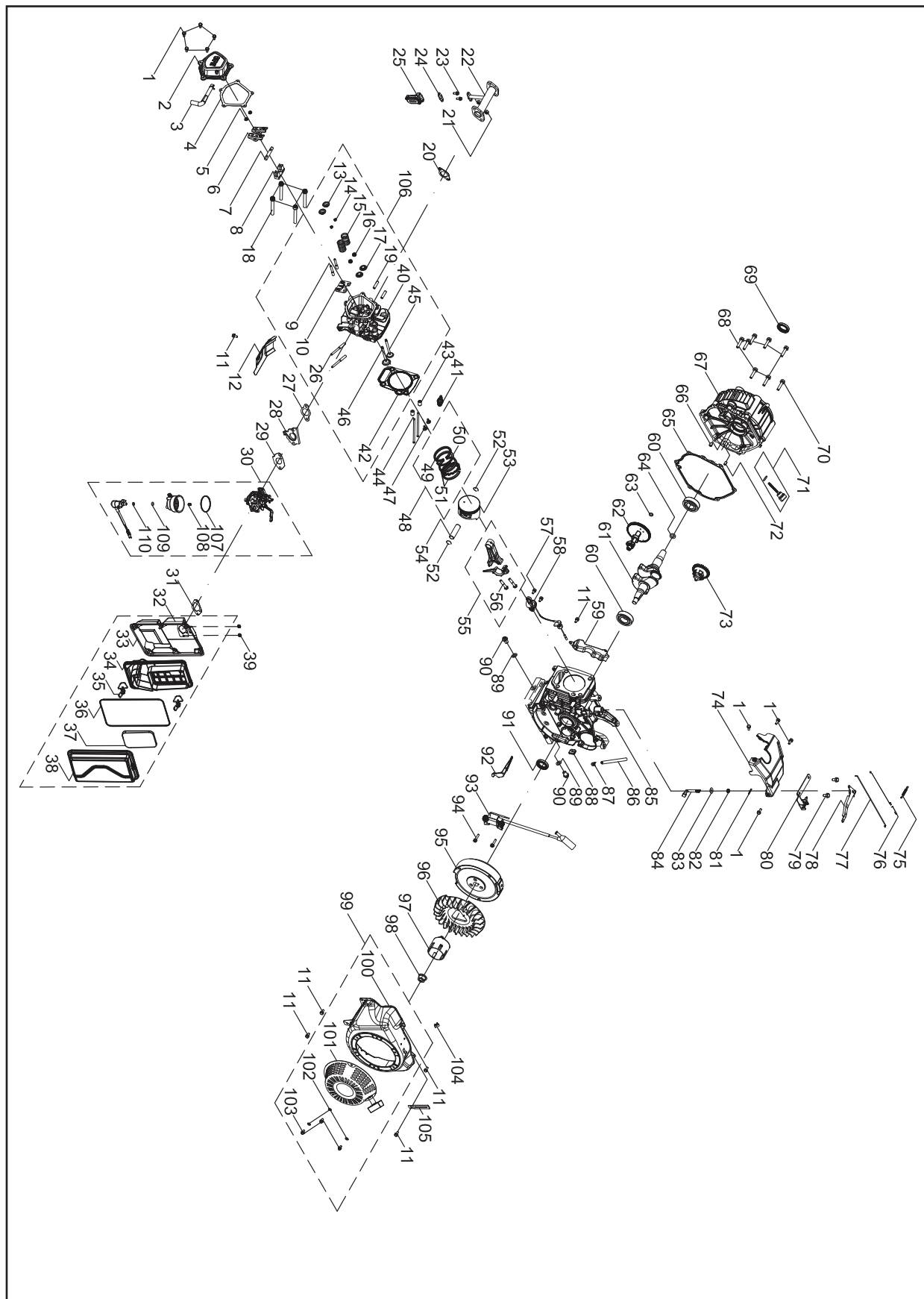



#	Part Number	Description	Qty
1	100011264-0003	Flange Bolt M6 x 16, GB5789	9
2	100002337	Cylinder Head Cover(Cpe)	1
3	100031973	Breather Tube	1
4	100010186	Gasket, Cylinder Head Cover	1
5	100011463-0002	Flange Nut M6	2
6	100004433	Rocker Arm Assembly	2
7	100004513	Shaft, Rocker Arm	1
8	100004507	Retainer, Rocker Arm	1
9	100004505	Bolt, Rocker Arm	2
10	100004479	Guide Plate, Push Rod	1
11	100011261-0004	Flange Bolt M6 x 12	6
12	100007112	Air Guide, Lower	1
13	100004516	Valve Spring Seat, 182F	2
14	100004576	Valve Collet	4
15	100004570	Spring Valve	2
16	100004602	Oil Seal, Valve	2
17	100004575	Valve Spring Seat, 173F	2
18	100002470	Flange Bolt M10 x 1.25 x 87	4
19	100010389	Stud Bolt M8 x 35	2
20	100006940	Gasket, Exhaust Pipe	1
21	100011422-0004	Flange Nut M8	2
22	100006989	Exhaust Pipe	1
23	100011216-0001	Flange Bolt M6 x 14	2
24	100008500	Gasket, Second Air Valve	1
25	100008497	Second Air Valve	1
26	100010363	Stud Bolt M6-8 x 98	2
27	100005574	Gasket, Insulator	1
28	100005609	Insulator, Carburetor	1
29	100005933	Gasket, Carburetor	1
30	100005518-0001	Carburetor	1
31	100005955	Gasket, Air Filter Base, 173F	1
32	100004747	Air Filter Assembly	1
33	100005024	Air Filter Base	1
34	100004878	Air Filter Separator	1
35	100004895	Air Filter Clip	2
36	100004798	Gasket, Air Filter Cover, 173F-2	1
37	100004781	Air Filter Element	1
38	100004874	Air Filter Cover	1
39	100011452-0003	Lock Nut M6, Flange	2
40	100002406	Cylinder Head	1
41	100009378	Spark Plug(F6RTC)	1
42	100010222	Gasket, Cylinder Head	1
43	100010562	Dowel Pin Ø12 x 20	2
44	100004411	Push Rod	2
45	100004554	Valve Exhaust	1
46	100004531	Valve Intake	1
47	100004268	Lifter, Valve	2
48	100003252	Piston Ring Set	1
49	100003157	1st Piston Ring	1
50	100003198	2nd Piston Ring	1
51	100003288	Oil Ring	1
52	100003221	Circlip	2
53	100003093	Piston	1
54	100003129	Wrist Pin	1
55	100003453	Connecting Rod	1
56	100003432	Bolt, Connecting Rod	2
57	100011217-0002	Flange Bolt M6 x 16	2

#	Part Number	Description	Qty
58	100010037	Oil Level Sensor	1
59	100007113	Shroud 2	1
60	100010788	Bearing TM6206 - P63	2
61	100003951	Crankshaft	1
62	100004320	Camshaft	1
63	100010522-0001	Washer Ø16 x Ø24 x 0.5	1
64	100030244	Washer Ø30 x Ø40 x 0.2	1
65	100010159	Gasket, Crankcase Cover	1
66	100010553	Dowel Pin Ø9 x 12	1
67	100003010	Cover, Crankcase	1
68	100011324-0001	Flange Bolt M8 x 38	7
69	100017652	Oil Seal Ø30 x Ø46 x 8, Spiral Grain	1
70	100011329-0001	Flange Bolt M8 x 45	1
71	100032059-0001	Oil Dipstick Assembly	1
72	100010544	Dowel Pin Ø7 x 14	1
73	100008303	Gear, Governor	1
74	100002444	Cylinder Head Shield	1
75	100007884	Spring, Governor	1
76	100007930	Spring, Throttle Return	1
77	100007957	Rod, Governor	1
78	100008400	Arm, Governor	1
79	100011309-0002	Flange Bolt M8 x 14	2
80	100008060	Control Assembly	1
81	100007989	Pin, Shaft	1
82	100017631	Oil Seal Ø8 x Ø14 x 4	1
83	100010518-0001	Washer Ø8 x Ø20 x 0.8	1
84	100007979	Shaft, Governor Arm	1
85	100002776	Crankcase	1
86	100017832	Pipe, Fuel, Ø4 x Ø10 x 155	1
87	100005138	Clamp Ø9.5 x 8	1
88	100000676	Rubber Block	1
89	100010467	Washer Ø12 x Ø20 x 2	2
90	100010275	Drain Bolt, M12 x 1.5 x 15	2
91	100017647	Oil Seal Ø30 x Ø46 x 8	1
92	100007114	Shroud 3	1
93	100009327	Ignition Module	1
94	100009362	Bolt M6 x 28, Ignition	2
95	100009562	Flywheel	1
96	100007032	Cooling Fan	1
97	100007560	Pulley, Starter	1
98	100011460-0001	Flange Nut M16 x 1.5	1
99	100007343-0003	Recoil Starter Assembly	1
100	100007663-0007	Fan Cover	1
101	100007407-0004	Recoil Starter	1
102	100010894-0001	Washer Ø6	3
103	100011565-0001	Flange Bolt M6 x 10	3
104	100000667	Clamp Ø8 x 8	1
105	100000655	Wire Clip B	1
106	100127019	Cylinder Head Assembly	1
107	100085766	Fuel Bowl O-Ring	1
108	100089154	Main Jet Standard	1
	100155680	Main Jet Altitude 1000-2000m	/
	100062832	Main Jet Altitude 2000-3000m	/
109	100134226	O-Ring, Solenoid Valve Base	1
110	100134227	O-Ring, Solenoid Valve	1

# TROUBLESHOOTING

Problem	Cause	Solution
Generator will not start	No fuel	Add fuel
	Faulty spark plug	Replace spark plug
	Unit loaded during start up	Remove load from unit
Generator will not start; Generator starts but runs roughly	Low oil level	Fill crankcase to the proper level Place generator on a flat, level surface
	Choke in the wrong position	Adjust choke
	Spark plug wire loose	Attach wire to spark plug
Generator shuts down during operation	Out of fuel	Fill fuel tank
	Low oil level	Fill crankcase to the proper level. Place generator on a flat, level surface
Generator cannot supply enough power or overheating	Generator is overloaded	Review load and adjust. See "Power Management"
	Insufficient ventilation	Check for air restriction. Move to a well ventilated area
No AC output	Cable not properly connected	Check all connections
	Connected device is defective	Replace defective device
	Circuit breaker is open	Reset circuit breaker
	Faulty brush assembly	Replace brush assembly (Service Center)
	Faulty AVR (auto voltage regulator)	Replace AVR (Service Center)
	Loose wiring	Inspect and tighten wiring connections
	Other	Contact the help line
Generator gallops	Engine governor defective	Contact the help line
Repeated circuit breaker tripping	Overload	Review load and adjust. See "Power Management"
	Faulty cords or device	Check for damaged, bare or frayed wires. Replace defective device

## For further technical support:

### Technical Service

Mon – Fri 8:30 AM – 5:00 PM (PST/PDT)

Toll Free: 1-877-338-0999

tech@championpowerequipment.com

# WARRANTY\*

CHAMPION POWER EQUIPMENT  
3 YEAR LIMITED WARRANTY

## Warranty Qualifications

To register your product for warranty and FREE lifetime call center technical support please visit:

<https://www.championpowerequipment.com/register>

To complete registration you will need to include a copy of the purchase receipt as proof of original purchase. Proof of purchase is required for warranty service. Please register within ten (10) days from date of purchase.

## Repair/Replacement Warranty

CPE warrants to the original purchaser that the mechanical and electrical components will be free of defects in material and workmanship for a period of three years (parts and labor) from the original date of purchase and 270 days (parts and labor) for commercial and industrial use. Transportation charges on product submitted for repair or replacement under this warranty are the sole responsibility of the purchaser. This warranty only applies to the original purchaser and is not transferable.

## Do Not Return The Unit To The Place Of Purchase

Contact CPE's Technical Service and CPE will troubleshoot any issue via phone or e-mail. If the problem is not corrected by this method, CPE will, at its option, authorize evaluation, repair or replacement of the defective part or component at a CPE Service Center. CPE will provide you with a case number for warranty service. Please keep it for future reference. Repairs or replacements without prior authorization, or at an unauthorized repair facility, will not be covered by this warranty.

## Warranty Exclusions

This warranty does not cover the following repairs and equipment:

### Normal Wear

Products with mechanical and electrical components need periodic parts and service to perform well. This warranty does not cover repair when normal use has exhausted the life of a part or the equipment as a whole.

### Installation, Use and Maintenance

This warranty will not apply to parts and/or labor if the product is deemed to have been misused, neglected, involved in an accident, abused, loaded beyond the product's limits, modified, installed improperly or connected incorrectly to any electrical component. Normal maintenance is not covered by this warranty and is not required to be performed at a facility or by a person authorized by CPE.

## Other Exclusions

This warranty excludes:

- Cosmetic defects such as paint, decals, etc.
- Wear items such as filter elements, o-rings, etc.
- Accessory parts such as starting batteries, and storage covers.
- Failures due to acts of God and other force majeure events beyond the manufacturer's control.
- Problems caused by parts that are not original Champion Power Equipment parts.

When applicable, this warranty does not apply to products used for prime power in place of a utility.

## Limits of Implied Warranty and Consequential Damage

Champion Power Equipment disclaims any obligation to cover any loss of time, use of this product, freight, or any incidental or consequential claim by anyone from using this product. THIS WARRANTY AND THE ATTACHED U.S. EPA and/or CARB EMISSION CONTROL SYSTEM WARRANTIES (WHEN APPLICABLE) ARE IN LIEU OF ALL OTHER WARRANTIES, EXPRESS OR IMPLIED, INCLUDING WARRANTIES OF MERCHANTABILITY OR FITNESS FOR A PARTICULAR PURPOSE.

A unit provided as an exchange will be subject to the warranty of the original unit. The length of the warranty governing the exchanged unit will remain calculated by reference to the purchase date of the original unit.

This warranty gives you certain legal rights which may change from state to state or province to province. Your state or province may also have other rights you may be entitled to that are not listed within this warranty.

## Contact Information

### Address

Champion Power Equipment, Inc.  
12039 Smith Ave.  
Santa Fe Springs, CA 90670 USA  
[www.championpowerequipment.com](http://www.championpowerequipment.com)

### Customer Service

Toll Free: 1-877-338-0999  
[info@championpowerequipment.com](mailto:info@championpowerequipment.com)  
Fax no.: 1-562-236-9429

### Technical Service

Toll Free: 1-877-338-0999  
[tech@championpowerequipment.com](mailto:tech@championpowerequipment.com)  
📞 EMERGENCY 24 HOUR SUPPORT: 1-562-204-1188

\*Except as otherwise stipulated in any of the following enclosed Emission Control System Warranties (when applicable) for the Emission Control System: U.S. Environment Protection Agency (EPA) and/or California Air Resources Board (CARB).

**CHAMPION POWER EQUIPMENT, INC. (CPE),  
THE UNITED STATES ENVIRONMENTAL PROTECTION AGENCY (U.S. EPA)  
AND THE CALIFORNIA AIR RESOURCES BOARD (CARB) EMISSION CONTROL SYSTEM WARRANTY**

**Your Champion Power Equipment (CPE) engine complies with both the U.S. EPA and state of California Air Resources Board (CARB) Exhaust and Evaporative emissions regulations.**

**YOUR WARRANTY RIGHTS AND OBLIGATIONS:**

The US EPA, California Air Resources Board, and CPE are pleased to explain the Federal and California Exhaust and Evaporative Emission Control Systems Warranty on your 2021 small off-road engine (SORE) and engine powered equipment. In California, new equipment that use small off-road engines (SORE) must be designed, built and equipped to meet the State's stringent anti-smog standards.

CPE must warrant the exhaust and evaporative emission control system on your small off-road engine (SORE) for the period listed below, provided there has been no abuse, neglect, unapproved modification, or improper maintenance of your equipment leading to the failure of the exhaust and evaporative emission control systems.

Your evaporative emission control system may include parts such as: carburetors, fuel tanks, fuel lines, (for liquid fuel and fuel vapors), fuel caps, valves, canisters, filters, clamps, connectors, and other associated components. Also included for your exhaust emission control system may be the fuel-injection system, the ignition system, catalytic converter and other exhaust emission related assemblies. Where a warrantable condition exists, CPE will repair your small off-road engine (SORE) at no cost to you including diagnosis, parts and labor.

**MANUFACTURER'S WARRANTY COVERAGE:**

This exhaust and evaporative emission control system is warranted for two years. If any exhaust and evaporative, emission related part on your engine or equipment is defective in, the part will be repaired or replaced by CPE.

**OWNER WARRANTY RESPONSIBILITIES:**

As the small off-road engine (SORE) owner, you are responsible for the performance of the required maintenance listed in your Owner's Manual. CPE recommends that you retain all your receipts covering maintenance on your small off-road engine (SORE), but CPE cannot deny warranty coverage solely for the lack of receipts.

As the small off-road engine (SORE) owner, you should be aware that CPE may deny you warranty coverage if your small off-road engine (SORE) or a part has failed due to abuse, neglect, improper maintenance or unapproved modifications.

You are responsible for presenting your small off-road engine to an Authorized CPE distribution center, service center or alternate service outlet as described in (3)(f) below or CPE dealer or CPE, Santa Fe Springs, Ca. as soon as the problem exists. The warranty repairs shall be completed in a reasonable amount of time, not to exceed 30 days.

If you have any questions regarding your warranty coverage, you should contact:

Champion Power Equipment, Inc.  
Customer Service  
12039 Smith Ave.  
Santa Fe Springs, CA 90670  
1-877-338-0999  
tech@championpowerequipment.com

## **EXHAUST AND EVAPORATIVE EMISSION CONTROL SYSTEM WARRANTY**

The following are specific provisions relative to your Exhaust and Evaporative Emission Control System (ECS) Warranty Coverage.

- 1. APPLICABILITY:** This warranty shall apply to 1995 and later model year California small off-road engines (SORE) (for other states, 1997 and later model year engines). The ECS Warranty Period shall begin on the date the new engine or equipment is delivered to its original, end-use purchaser, and shall continue for 24 consecutive months thereafter.
- 2. GENERAL EMISSIONS WARRANTY COVERAGE**

CPE warrants to the original, end-use purchaser of the new engine or equipment and to each subsequent purchaser that each of its small off-road engines (SORE) is:

  - 2a. Designed, built and equipped to conform to U.S. EPA emissions standards for spark-ignited engines at or below 19 kilowatts and all applicable regulations adopted by the California Air Resources Board and
  - 2b. Free from defects in materials and workmanship that cause the failure of a warranted part to be identical in all material respects to the part as described in the engine manufacturer's application for certification for a period of two years.
- 3. THE WARRANTY ON EXHAUST AND EVAPORATIVE EMISSION-RELATED PARTS WILL BE INTERPRETED AS FOLLOWS:**
  - 3a. Any warranted part that is not scheduled for replacement as required maintenance in the Owner's Manual shall be warranted for the ECS Warranty Period. If any such part fails during the ECS Warranty Period, it shall be repaired or replaced by CPE according to Subsection "d" below. Any such part repaired or replaced under the ECS Warranty shall be warranted for any remainder of the ECS Warranty Period.
  - 3b. Any warranted, exhaust and evaporative emissions-related part which is scheduled only for regular inspection as specified in the Owner's Manual shall be warranted for the ECS Warranty Period. A statement in such written instructions to the effect of "repair or replace as necessary", shall not reduce the ECS Warranty Period. Any such part repaired or replaced under the ECS Warranty shall be warranted for the remainder of the ECS Warranty Period.
  - 3c. Any warranted, exhaust and evaporative emissions-related part which is scheduled for replacement as required maintenance in the Owner's Manual shall be warranted for the period of time prior to the first scheduled replacement point for that part. If the part fails prior to the first scheduled replacement, the part shall be repaired or replaced by CPE according to Subsection "d" below. Any such exhaust and evaporative emissions-related part repaired or replaced under the ECS Warranty, shall be warranted for the remainder of the ECS Warranty Period prior to the first scheduled replacement point for such emissions-related part.
  - 3d. Repair or replacement of any warranted, exhaust and evaporative emissions-related part under this ECS Warranty shall be performed at no charge to the owner at a CPE Authorized Service Outlet.
  - 3e. The owner shall not be charged for diagnostic labor which leads to the determination that a part covered by the ECS Warranty is in fact defective, provided that such diagnostic work is performed at a CPE Authorized Service Outlet.
  - 3f. CPE shall pay for covered exhaust and evaporative emissions warranty repairs at non-authorized service outlets under the following circumstances:
    - i. The service is required in a population center with a population over 100,000 according to U.S. Census 2000 without a CPE Authorized Service Outlet AND
    - ii. The service is required more than 100 miles from a CPE Authorized Service Outlet. The 100 mile limitation does not apply in the following states: Alaska, Arizona, Colorado, Hawaii, Idaho, Montana, Nebraska, Nevada, New Mexico, Oregon, Texas, Utah and Wyoming.
  - 3g. CPE shall be liable for damages to other original engine components or approved modifications proximately caused by a failure under warranty of an emission-related part covered by the ECS Warranty.
  - 3h. Throughout the ECS Warranty Period, CPE shall maintain a supply of warranted exhaust and evaporative emission-related parts sufficient to meet the expected demand for such exhaust and evaporative emission-related parts.
  - 3i. Any CPE Authorized and approved exhaust and evaporative emission-related replacement part may be used in the performance of any ECS Warranty maintenance or repair and will be provided without charge to the owner. Such use shall not reduce CPE's warranty obligation.
  - 3j. Unapproved add-on or modified parts may not be used to modify or repair a CPE engine. Such use voids this ECS Warranty and shall be sufficient grounds for disallowing an ECS Warranty claim. CPE shall not be liable hereunder for failures of any warranted parts of a CPE engine caused by the use of such an unapproved add-on or modified part.

**EMISSION-RELATED PARTS INCLUDE THE FOLLOWING: (using those portions of the list applicable to the engine)**

<b>Systems covered by this warranty</b>	<b>Parts Description</b>
Fuel Metering System	Carburetor and internal parts (and/or pressure regulator or fuel injection system), Air/fuel ratio feedback and control system, Cold start enrichment system.
Air Induction System	Controlled hot air intake system, Intake manifold, Air filter.
Ignition System	Spark plug, Magneto or electronic ignition system, Spark advance/retard system.
Exhaust Gas Recirculation (EGR) System	EGR valve body, and carburetor spacer if applicable, EGR rate feedback and control system.
Air Injection System	Air pump or pulse valve, Valves affecting distribution of flow, Distribution manifold.
Catalyst or Thermal Reactor System	Catalytic Converter, Thermal Reactor, Exhaust Manifold.
Particulate Controls	Traps, Filters, Precipitators, and any other device used to capture particulate emissions.
Miscellaneous items used in Above Systems	Vacuum, Temperature, and time sensitive valves and switches, Electronic Controls, Hoses, Belts, Connectors, and Assemblies.
Evaporative Controls	Fuel Tank, Fuel Cap, Fuel Lines (for liquid fuel and fuel vapors), Fuel Line Fittings, Clamps, Pressure Relief Valves, Control Valves, Control Solenoids, Electronic Controls, Vacuum Control Diaphragms, Control Cables, Control Linkages, Purge Valves, Gaskets, Liquid/Vapor Separator, Carbon Canister, Canister Mounting Brackets, Carburetor Purge Port Connector.

**TO OBTAIN WARRANTY SERVICE:**

You must take your CPE engine or the product on which it is installed, along with your warranty registration card or other proof of original purchase date, at your expense, to any Champion Power Equipment dealer who is authorized by Champion Power Equipment, Inc. to sell and service that CPE product during his normal business hours. Alternate service locations defined in Section (3)(f) above must be approved by CPE prior to service. Claims for repair or adjustment found to be caused solely by defects in material or workmanship will not be denied because the engine was not properly maintained and used.

**If you have any questions regarding your warranty rights and responsibilities, or to obtain warranty service, please write or call Customer Service at Champion Power Equipment, Inc.**

**Champion Power Equipment, Inc.**  
 12039 Smith Ave.  
 Santa Fe Springs, CA 90670  
 1-877-338-0999  
 Attn.: Customer Service  
[tech@championpowerequipment.com](mailto:tech@championpowerequipment.com)