



10006 Santa Fe Springs Road
Santa Fe Springs, CA 90670 USA
Made in China

18051
Rev 18051-20100204



Owner's Manual and Operating Instructions



SAVE THESE INSTRUCTIONS

**Important Safety
Instructions are included in
this manual**

8000 lb.

WINCH

Table of Contents

Introduction.....	1	Troubleshooting	13
Accessories	1	Warranty	14
This Booklet	1	Warranty Qualifications.....	14
Manual Conventions	2	Repair/Replacement Warranty	14
Safety Rules	3	Do not return the unit to the place of	
Controls and Features	5	purchase	14
Mounting	6	Warranty Exclusions.....	14
Mounting the Winch.....	6	Normal Wear	14
Operation.....	7	Installation, Use and Maintenance	14
General Tips for Safe Operation	7	Other Exclusions	14
Self Recovery.....	7	Limits of Implied Warranty and	
Winching Techniques A-Z	8	Consequential Damage	14
Maintenance	9	Contact Information	14
Lubrication.....	9	Notes	15
Cable Assembly Replacement.....	9		
Specifications.....	10		
Performance Specifications	10		
Winch Diagram	11		
Winch Parts List.....	12		

Introduction

Congratulations on your purchase of a Champion Power Equipment winch. CPE designs and builds winches to strict specifications. With proper use and maintenance, this winch will bring years of satisfying service.

This Owner's Manual contains important safety instructions and information. **SAVE THESE INSTRUCTIONS FOR FUTURE REFERENCE.**

Accessories

Champion Power Equipment manufactures and sells accessories designed to help you get the most from your purchase. To find out more about our covers, tree savers, hooks, fairleads, etc., please visit our web site at

www.championpowerequipment.com

Record the model and serial numbers as well as date and place of purchase for future reference. Have this information available when ordering parts and when making technical or warranty inquiries.

Champion Power Equipment Support
1-877-338-0999
Model Number
18051
Serial Number
Date of Purchase
Purchase Location

This Booklet

Every effort has been made to ensure the accuracy and completeness of the information in this manual. We reserve the right to change, alter and/or improve the product and this document at any time without prior notice.

Manual Conventions

Manual Conventions

This manual uses the following symbols to help differentiate between different kinds of information. The safety symbol is used with a key word to alert you to potential hazards in operating and owning power equipment.

Follow all safety messages to avoid or reduce the risk of serious injury or death.

DANGER

DANGER indicates an imminently hazardous situation which, if not avoided, *will* result in death or serious injury.

WARNING

WARNING indicates a potentially hazardous situation which, if not avoided, *could* result in death or serious injury.

CAUTION

CAUTION indicates a potentially hazardous situation which, if not avoided, *may* result in minor or moderate injury.

CAUTION

CAUTION used without the safety alert symbol indicates a potentially hazardous situation which, if not avoided, *may* result in property damage.

NOTE

If you have questions regarding your winch, we can help. Please call our help line at 1-877-338-0999.

Safety Rules

WARNING

Read this manual thoroughly before operating your winch. Failure to follow instructions could result in serious injury or death.

WARNING

Do not exceed the rated capacity.

DANGER

Do not use this winch for lifting or moving people or animals.

DANGER

Keep yourself and others a safe distance to the side of the cable when under tension.

DANGER

Never step over a cable or near a cable under load.

WARNING

The wire rope may break before the motor stalls. For heavy loads at or near rated capacity, use a pulley block/snatch block to reduce the load on the wire rope.

WARNING

Do not move the vehicle to pull a load (towing) on the winch cable. This could result in cable breakage.

WARNING

Pull only on areas of the vehicle as specified by the vehicle manufacturer

WARNING

Do not use the winch to secure or hold a vehicle for a long period of time. Do not use the winch to secure a vehicle for transport.

WARNING

Disconnect the remote control and battery leads when not in use.

WARNING

Avoid "shock loads" by using the control switch intermittently to take up the slack in the wire rope. "Shock loads" can far exceed the rate capacity for the wire rope and drum.

Do not accelerate your vehicle while winching. Loss of traction can cause a shock load on the cable.

Safety Rules

WARNING

Batteries contain acid and produce explosive gases.

Keep sparks, flames and cigarettes away from batteries at all times. Wear safety glasses and protect the eyes at all times. Do not lean over the batteries during operation.

WARNING

When re-spooling the cable, ensure that the cable spools in the under-wind position with the cable entering the drum from the bottom, not the top.

To re-spool correctly, and while wearing gloves, keep a slight load on the cable while pushing the remote button to draw in the cable. Walk toward the winch not allowing the cable to slide through your hands. Do not let your hands get within 12" of the winch while re-spooling. Turn off the winch and repeat the procedure until a few feet of cable is left. Disconnect the remote control and finish spooling by rotating the drum by hand with the clutch disengaged. Keep hands clear of the fairlead and drum while the winch is under power.

WARNING

Do not use as a hoist. Do not use for overhead lifting.

CAUTION

Use gloves to protect hands when handling the cable. Never let the cable slide through your hands.

CAUTION

Do not wrap the cable around any object and hook it back onto itself.

CAUTION

Apply blocks to the wheels of the vehicle when on an incline.

CAUTION

Duration of winching pulls should be kept as short as possible.

If the motor becomes uncomfortably hot to the touch, stop winching immediately and let it cool down for a few minutes. Do not pull for more than one minute at or near the rated load.

CAUTION

If the motor stalls, do not maintain power to the winch.

Electric winches are designed and made for intermittent use and should not be used in constant duty applications.

CAUTION

Never release the free-spool clutch when there is a load on the winch.

CAUTION

Use hook strap when handling the hook for spooling or unspooling the wire rope.

Controls and Features

Read this owner's manual before operating your winch. Familiarize yourself with the location and function of the controls and features. Save this manual for future reference.

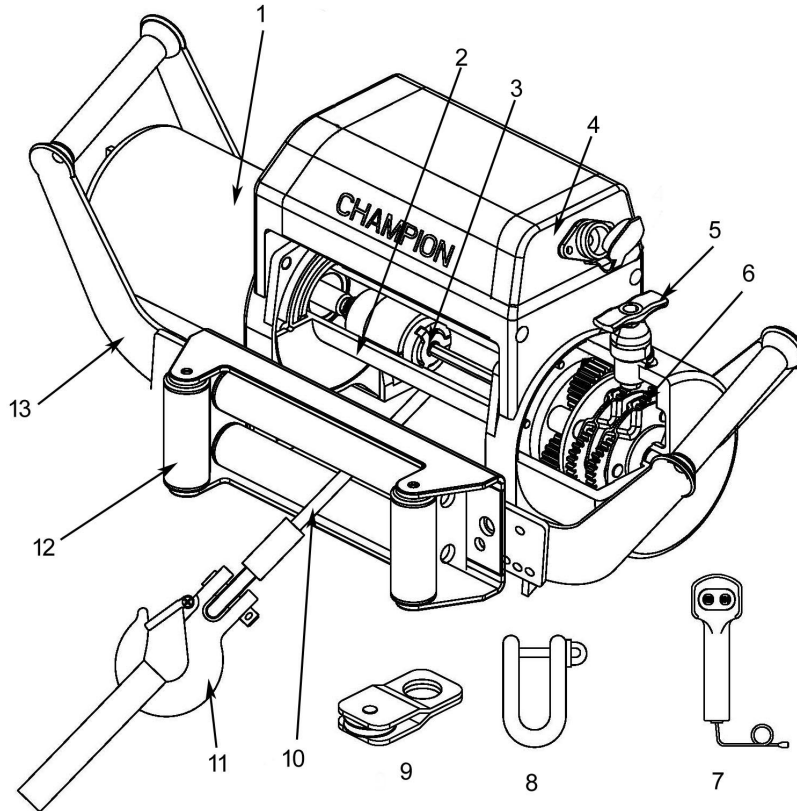

(1) Motor - 3.6 HP 12V DC motor provides power to the planetary gear mechanism.

(2) Winch Drum -The winch drum is the cylinder on which the wire rope is stored.

(3) Braking System - Braking action is automatically applied to the winch drum by a separate mechanical brake when the winch motor is stopped and there is a load on the wire rope.

(4) Solenoid - Power from the vehicle battery flows through the weather sealed solenoid switch before being directed to the winch motor.

(5) Free spooling Clutch - The clutch allows the operator to manually disengage ("Out") the spooling drum from the gear train, free spool. Engaging the clutch ("In") locks the winch into the gear system.

(6) Planetary Gear System - The reduction gears convert the winch motor power into extreme pulling forces. This system allows high torque while maintaining compact size and light weight.

(7) Remote Switch - Dual switches for powering the rope in or out of your winch drum.

(8) D -Shackle

(9) Snatch Block - Used properly, the snatch block can double the pulling power of winch, or change your pulling directly without damaging the wire rope.

(10) Wire Rope - 5/16" x 95' galvanized aircraft cable designed specifically for load capacity of 10,000lbs.

(11) Clevis Hook: Provides a means for connecting the looped ends of cables to an anchor.

(12) Roller Fairlead - When using the winch at an angle the roller fairlead acts to guide the wire rope onto the drum and minimizes damage to the wire rope from abrasion on the winch mount or bumper.

(13) Speed Mount™ Hitch Adapter - Adapter for front or rear end class III hitch receiver mounting and off-vehicle storage.

Mounting

Mounting

This CPE 8,000 lb winch is designed with a bolt pattern that is standard in this class of winch. Many winch mounting kits are available that utilize this bolt pattern for the most popular trucks and Sport Utility Vehicles. If you cannot find a kit locally, contact CPE and we will provide you with the name of a dealer near you.

If you will utilize the CPE Speed Mount™ Hitch Adapter, you must ensure that the three major sections (motor, drum and gear housing) are properly aligned. Proper alignment of the winch will allow even distribution of the full rated load.

Mounting the Winch

1. Insert 2 M10x35 bolts to the mounting channel hole and attach the roller fairlead to the mounting channel with the 2 Flat Washers, Lock washers and Nut M10 provided.

CAUTION

Mounting bolts must be SAE grade 5 or better and torque to 34 ft. lbs.

2. Extend the arms of the Speed Mount™ Hitch Adapter and secure with 4 M8 bolts and M8 nuts.
3. Turn the winch up-side-down; insert 4 M10 Nuts into the holes of the winch.
4. Place the Speed Mount™ Hitch Adapter on the winch, making sure the winch is

centered in the middle of the mounting channel. Disengage the clutch by moving the Cam Ring to the “Out” position.

Release the wire rope and pull through the slot in the front of the channel.

5. Attach using the 4 M10 Cap Screws with 4 Lock washers and Flat washers into the hole.
6. Attach the clevis hook and hand strap.
7. Connect the battery leads. **FOR WINCH TO FUNCTION PROPERLY:** Connect the red (positive) lead to the positive (+) terminal of the vehicle’s 12 volt battery. Connect the black (negative) lead to the negative (-) terminal of the vehicle’s 12 volt battery.

CAUTION

Battery cables should not be drawn taut. Leave some slack for cable movement.

8. Attach the remote lead to the winch and test for proper operation
9. Check for proper drum rotation. Turn the clutch handle to the “out” position (Free spooling). Pull out some cable from the drum, and then turn the clutch knob to the “In” position to engage the gears. Press the cable out button on the power switch. If the drum is turning and releasing more cable then your connections are accurate. If the drum is turning and collecting more cable then reverse the leads on the motor. Repeat and check rotation.

Operation

General Tips for Safe Operation

Your 18051 winch is rated at 8,000 lbs. capacity in first layer (max) when spooling the first rope layer on the drum. Overloads can damage the winch, motor and/or wire rope. For loads over 5,500 lbs. we recommend the use of the pulley block/snatch block to double the wire rope line. This will aid in two ways:

- reduce the number or rope layers on the drum, as well as,
- reduce the load on the wire rope by as much as 50%.

When doubling the line back to the vehicle, attach to the tow hook, frame or other load bearing part.

The vehicle engine should be kept running during operation of the winch to minimize battery drain and maximize power and speed of the winch. If the winch is used for a considerable time with the engine off the battery may be drained and too weak to restart the engine.

Get to know your winch before you actually need to use it. We recommend that you set up a few test runs to familiarize yourself with rigging techniques, the sounds your winch makes under various loads, the way the cable spools on the drum, etc.

Inspect the wire rope and equipment before each use. A frayed or damaged rope shall be replaced immediately. Use only manufacturer's identical replacement rope with the exact specifications.

Inspect the winch installation and bolts to ensure that all bolts are tight before each operation.

Store the remote control inside your vehicle in a place that it will not be damaged.

Any winch that appears to be damaged in any way, is found to be worn, or operates abnormally **MUST BE REMOVED FROM SERVICE UNTIL REPAIRED**. It is recommended that the necessary repairs be made by a manufacturer's authorized repair facility.

Pull only on areas of the vehicle as specified by the vehicle manufacturer.

Only attachments and/or adapters supplied by the manufacturer are to be used.

Self Recovery

Locate a suitable anchor such as a strong tree trunk or boulder. Always use a sling as an anchor point.

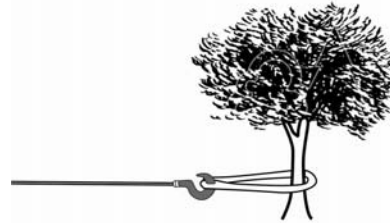

Your winch is equipped with a roller fairlead to help guide the wire rope and to reduce binding on short side pulls.

Do not winch from an acute angle as the wire rope will pile up on one side of the drum causing damage to wire rope and the winch.

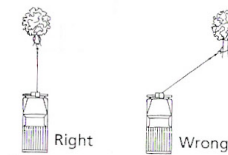

Short pulls from an angle can be used to straighten the vehicle. Long pulls should be done with the wire rope at a 90° angle to the winch/vehicle.

When pulling a heavy load, place a blanket or jacket over the wire rope five or six feet from the hook.

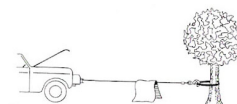

In the event of a broken cable it will dampen the snap back. For additional protection open the hood of the vehicle.

For pulls over 8,000lbs., we recommend the use of the snatch block/pulley block to double line the wire rope.

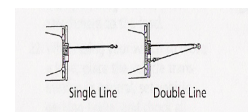

This reduces the load on the winch and the strain on the rope by approximately 50%

Operation

Winching Techniques A-Z

- a. Take time to assess your situation and plan your pull.
- b. Put on gloves to protect your hands.
- c. Disengage the clutch to allow free-spooling and also save battery power.
- d. Attach the hook strap to the clevis hook.
- e. Pull out the wire rope to your desired anchor point using the hook strap.
- f. Secure the clevis hook to the anchor point: Sling, chain or snatch block. Do not attach the hook back onto the wire rope.
- g. Engage the clutch.
- h. Connect the remote control to the winch. If you are going to control the winch from inside your vehicle then pass the remote through an open window to avoid the wires being pinched in the door.
- i. Start your engine to ensure power is being replenished to the battery.
- j. Power in the wire rope guiding the wire under tension to draw up the slack in the wire. Once the wire is under tension, stand clear. Never step over the wire rope.
- k. Double check your anchors and make sure all connections are secure.
- l. Inspect the wire rope. Make sure there are at least 5 wraps of wire rope around the winch drum.
- m. Drape a blanket or jacket over the wire rope approximately 5 to 6 feet from the hook. Open the hood for added protection.
- n. Clear the area. Make sure all spectators stand clear and that no one is directly in front or behind the vehicle or anchor point.
- o. Begin winching. Be sure that the wire rope is winding evenly and tightly around the drum. The vehicle that is being winched can be slowly driven to add assistance to the winching process. Avoid shock loads; keep the wire rope under tension.
- p. The vehicle to be winched should be placed in neutral and the emergency brake released. Only release the brake pedal when under full tension. Avoid shock loads to the winch. This can damage the winch, rope and vehicle.
- q. The winch is meant for intermittent use. Under full load with a single line rig do not power in for more than a minute without letting the motor cool down for a few minutes and then resume the winching operation.
- r. The winching operation is complete once the vehicle is on stable ground and is able to drive under its own power.
- s. Secure the vehicle. Be sure to set the brakes and place the vehicle in park.
- t. Release the tension on the wire rope. The winch is not meant to hold the vehicle for long periods of time.
- u. Disconnect the wire rope from the anchor.
- v. Rewind the wire rope. Make sure that any wire already on the drum has spooled tightly and neatly. If not, draw out the wire and re-spool from the point where the rope is tight.
- w. Keep your hands clear of the winch drum and fairlead as the wire rope is being drawn in.
- x. Secure the hook and hook strap.
- y. Disconnect the remote control and store in a clean, dry place.
- z. Clean and inspect connections and mounting hardware for next winching operation.

Maintenance

The owner/operator is responsible for all periodic maintenance.

WARNING

Never operate a damaged or defective winch.

WARNING

Improper maintenance will void your warranty.

Complete all scheduled maintenance in a timely manner. Correct any issue before operating the winch.

NOTE

For service or parts assistance, contact our help line at 1-877-338-0999.

Lubrication

All moving parts within the Electric Winch having been lubricated using high temperature lithium grease at the factory. No internal lubrication is required. Lubricate Cable Assembly periodically using a light, penetrating oil.

Cable Assembly Replacement

It is recommended that any modifications be performed by a manufacturer's authorized repair facility, and that only manufacturer-supplied parts be used

1. Move Clutch Handle to the "Out" position.
2. Extend Cable Assembly to its full length. Note how the existing cable is connected to the inside of the drum.
3. Remove old Cable Assembly and attach new one.
4. Retract Cable Assembly onto drum being careful not to allow kinking.

Specifications

Specifications

Performance Specifications

Rated Pull	8,000 lbs (3629 kg)
Gear Reduction Ratio	216:1
Motor	Series Wound Motor 3.6 HP/2.7 KW (DC 12V)
Duty Cycle	Intermittent Use Only
Drum Size	2.48" (D) x 8.84" (L) 63 mm (D) x 224.5 mm (L)
Cable	5/16" (D) x 95' (L) 8 mm (D) x 29 m (L) (over 89 useable feet with five wraps on the winch drum)
Weight	108.6 lbs. (49.3 kg)
Height	10.52 inches (267 mm)
Width	5.6 inches (142 mm)
Length	21.06 inches (535 mm)
Bolt Pattern	10" x 4.5" (254 mm x 114.3 mm)

Line speed and Motor Current (First layer)						
Line pull Max	lbs	0	2000	4000	6000	8000
	kgs	0	907	1814	2722	3629
Line speed (12VDC)	FPM	16	9.8	6.9	5.6	4.6
	MPM	4.9	3	3.1	1.7	1.4
Max Current	amps	115	200	270	320	380
Running Time	minutes	1	1	1	1	1
Cooling Time	minutes	5	5	5	5	5

*If the motor becomes uncomfortably hot to the touch, stop winching immediately and let it cool down for 5 minutes. Do not pull for more than one minute at or near the rated load.

**Electric winches are designed and made for intermittent use and should not be used in constant duty applications.

Line pull and cable capacity					
Layers of cable on drum		1	2	3	4
Max pulling capacity per layer	lbs	8000	6500	5500	4700
	kgs	3629	2948	2495	2134
Cable capacity per layer	ft	20.3	44.3	71.7	95
	m	6.2	13.5	21.9	29

* Use double line and snatch block for pulling loads over 5,500lbs / 2495kgs.

Winch Diagram

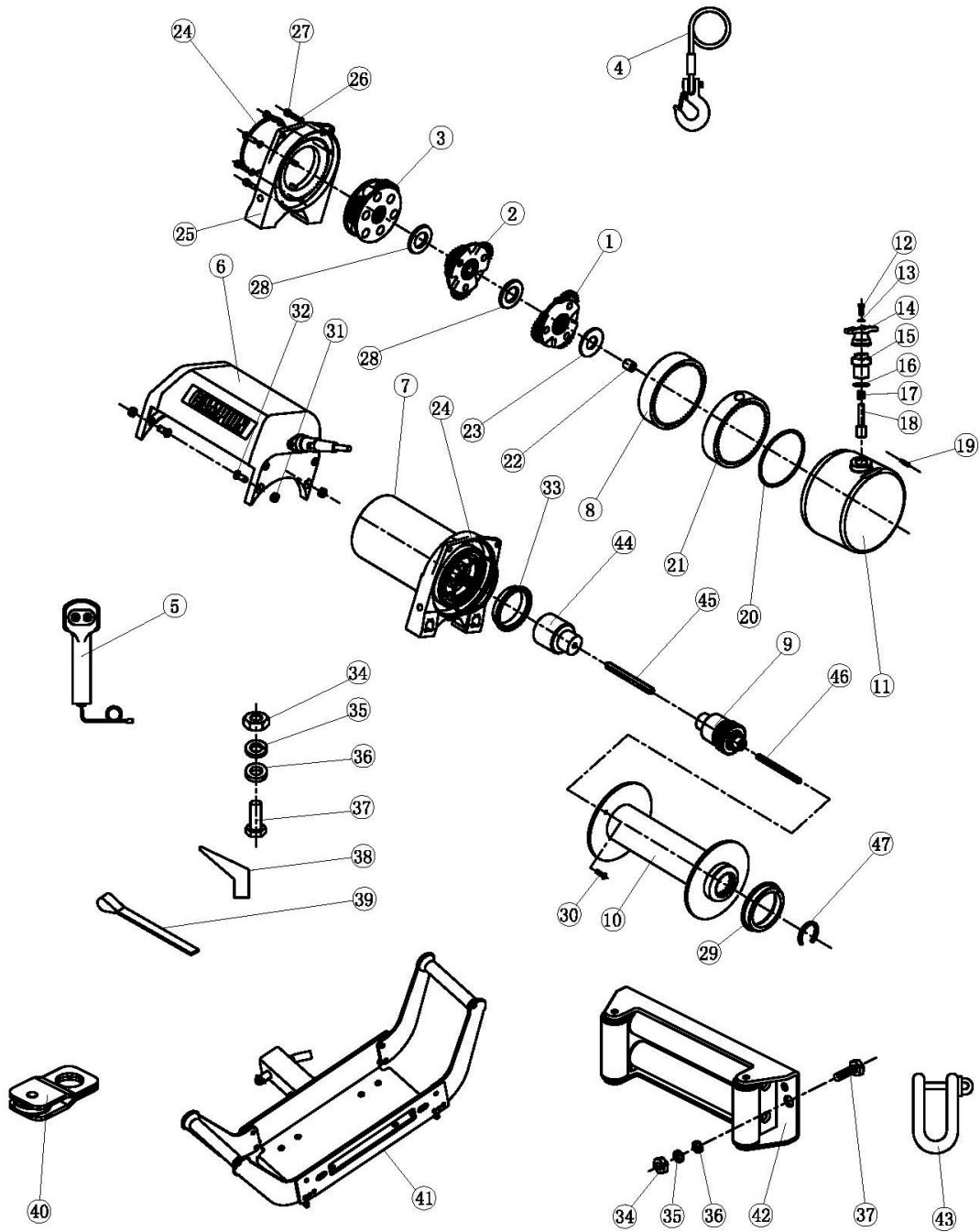

Specifications

Winch Parts List

No.	Part number	Description	Qty
1	P1010100	Gear Carrier Assembly - Input	1
2	P1010200	Gear Carrier Assembly - Intermediate	1
3	P1010300-N	Gear Carrier Assembly - Output	1
4	810400	Cable Assembly	1
5	P1011001-B	Switch Assembly	1
6	P1011003-BC	Up-setting Solenoid Assembly	1
7	811300-BC	Motor/End Bearing Assembly	1
8	P1011021	Gear Housing A	1
9	810600-NA	Brake Assembly	1
10	P1010900-N-BA	Drum Assembly	1
11	P1011005-N-BC	Gear Housing End Cover	1
12	P1011022	Pan Head Screw M5x15	1
13	P1011023	Washer 5	1
14	P1011024	Clutch Handle	1
15	P1011025	Clutch Seat	1
16	P1011026	Seal Ring 20×1.8	1
17	P1011027	Spring	1
18	P1011028	Clutch Pin	1
19	P1011029	Set Screw M4×8	1
20	P1011010	Gear Housing End Cover Seal	1
21	P1011030	Gear Housing B	1
22	P1011012	Bushing	1
23	P1011013	Thrust Washer	1
24	P1011014	Motor/End Bearing Seal	2
25	P1011032-BC	End Bearing	1
26	P1011016	Lock Washer 6	8
27	P1011017	Cap Screw M6×20	8
28	P1011018	Thrust Disc	2
29	P1010008	Bushing -Drum	1
30	P1010012	Cap Screw M6×10	1
31	P1010013	Lock Nut M8	4
32	P1010014	Cap Screw M8×22	4
33	P1010015	Motor/Drum Bushing	1
34	810024	Lock Nut M10	6
35	810023	Flat Washer 10	6
36	810022	Lock Washer 10	6
37	810021	Cap Scerw M10×35	6
38	810025-N	Terminal Protector	3
39	300900	Strap	1
40	811100-BC	Snatch Block	1
41	P1011200-BC	Speed Mount™ Hitch Adapter	1
42	811000-BC	Roller Fairlead	1
43	811200	D-Shackle	1
44	810033	Motor Coupling	1
45	P1011033	Hexagonal Shaft I	1
46	P1011034	Hexagonal Shaft II	1
47	810035	Retainer-Ring 50	1

Troubleshooting

Problem	Cause	Solution
Motor does not turn on	Switch Assembly not connected properly	Insert Switch Assembly all the way into the connector.
	Loose battery cable connections	Tighten nuts on all cable connections.
	Solenoid malfunctioning	Tap solenoid to loosen contacts. Apply 12 volts to coil terminals directly. A clicking indicates proper activation.
	Defective Switch Assembly	Replace Switch Assembly.
	Defective motor	Check for voltage at armature port with Switch pressed. If voltage is present, Replace motor.
	Water has entered motor	Allow to drain and dry. Run in short bursts without load until completely dry.
Motor runs but Cable drum does not turn	Clutch not engaged	Move Clutch Handle to the "In" position. If problem persists, a qualified technician needs to check and repair.
Motor runs slowly or without normal power	Insufficient current or voltage	The battery is weak, recharge. Run winch with vehicle motor running (Battery should have a strong charge)
	Loose or corroded battery cable connections.	Clean, Tighten, or replace.
Motor overheating	winch running time too long	Allow winch to cool down periodically.
Motor runs in one direction only	Defective or stuck Solenoid	Tap Solenoid to loosen contacts.
		Repair or Replace solenoid.
	Defective Switch Assembly	Replace Switch Assembly.

Warranty

Warranty

CHAMPION POWER EQUIPMENT
TWO (2) YEAR LIMITED WARRANTY

Warranty Qualifications

Champion Power Equipment (CPE) will register this warranty upon receipt of your Warranty Registration Card and a copy of your sales receipt from one of CPE's retail locations as proof of purchase.

Please submit your warranty registration and your proof of purchase within ten (10) days of the date of purchase.

Repair/Replacement Warranty

CPE warrants to the original purchaser that the mechanical and electrical components will be free of defects in material and workmanship for a period of one year (parts and labour) and two years (parts) from the original date of purchase (90 days (parts and labour) and 180 days (parts) for commercial & industrial use). Transportation charges on product submitted for repair or replacement under this warranty are the sole responsibility of the purchaser. This warranty only applies to the original purchaser and is not transferable.

Do not return the unit to the place of purchase

Contact CPE's Technical Service and CPE will troubleshoot any issue via phone or e-mail. If the problem is not corrected by this method, CPE will, at its option, authorize evaluation, repair or replacement of the defective part or component at a CPE Service Center. CPE will provide you with a case number for warranty service. Please keep it for future reference. Repairs or replacements without prior authorization, or at an unauthorized repair facility, will not be covered by this warranty.

Warranty Exclusions

This warranty does not cover the following repairs and equipment:

Normal Wear

Winches need periodic parts and service to perform well. This warranty does not cover repair when normal use has exhausted the life of a part or the equipment as a whole.

Installation, Use and Maintenance

This warranty will not apply to parts and/or labor if this winch is deemed to have been misused,

neglected, involved in an accident, abused, loaded beyond the winch's limits, modified, installed improperly or connected incorrectly to any electrical component. Normal maintenance is not covered by this warranty.

Other Exclusions

This warranty excludes:
The winch cable.

Cosmetic defects such as paint, decals, etc.
Accessory parts such as storage covers.
Failures due to acts of God and other force majeure events beyond the manufacturer's control.

Problems cause by parts that are not original Champion Power Equipment parts.

Limits of Implied Warranty and Consequential Damage

Champion Power Equipment disclaims any obligation to cover any loss of time, use of this product, freight, or any incidental or consequential claim by anyone from using this winch. THIS WARRANTY IS IN LIEU OF ALL OTHER WARRANTIES, EXPRESS OR IMPLIED, INCLUDING WARRANTIES OF MERCHANTABILITY OR FITNESS FOR A PARTICULAR PURPOSE

A unit provided as an exchange will be subject to the warranty of the original unit. The length of the warranty governing the exchanged unit will remain calculated by reference to the purchase date of the original unit.

This warranty gives you certain legal rights which may change from state to state. Your state may also have other rights you may be entitled to that are not listed within this warranty.

Contact Information

Address

Champion Power Equipment, Inc.
10006 Santa Fe Springs Rd.
Santa Fe Springs, CA 90670

Customer Service

Mon – Fri 8:30 AM – 5:00 PM (PST/PDT)
Toll Free: 1-877-338-0999
Fax no.: 1-562-236-9429

Technical Service

Mon – Fri 8:30 AM – 5:00 PM (PST/PDT)
Toll Free: 1-877-338-0999
tech@championpowerequipment.com

Notes