

# CHAMPION

POWER EQUIPMENT™

10006 Santa Fe Springs Road  
Santa Fe Springs, CA 90670 USA  
Made in China

30007  
Rev 30007-20080208



## Owner's Manual and Operating Instructions



13 Gallon

# AIR COMPRESSOR



# Table of Contents

---

<b>Introduction</b> .....	<b>1</b>	<b>Troubleshooting</b> .....	<b>13</b>
This Booklet .....	1	<b>Warranty</b> .....	<b>15</b>
<b>Manual Conventions</b> .....	<b>2</b>	Warranty Qualifications .....	15
<b>Safety Rules</b> .....	<b>3</b>	Repair/Replacement Warranty .....	15
<b>Controls and Features</b> .....	<b>5</b>	Do not return the unit to the place of	
13 gallon Air Compressor .....	5	purchase .....	15
<b>Assembly</b> .....	<b>6</b>	Warranty Exclusions.....	15
Add Compressor Oil .....	6	Normal Wear .....	15
Attach Air Filter .....	6	Installation, Use and Maintenance.....	15
Break-In Procedure .....	6	Other Exclusions .....	15
<b>Operation</b> .....	<b>7</b>	Limits of Implied Warranty and	
Start Up Procedure .....	7	Consequential Damage .....	15
Shutdown and Storage .....	7	Contact Information .....	15
<b>Maintenance</b> .....	<b>8</b>	Address.....	15
Compressor Maintenance .....	8	Customer Service .....	15
Oil Change.....	8	Technical Service.....	15
Checking Safety Relief Valve .....	8	<b>Notes</b> .....	<b>16</b>
Air Filter .....	8		
Maintenance Schedule.....	8		
<b>Specifications</b> .....	<b>9</b>		
13 Gallon Portable Air Compressor .....	9		
Parts Diagram.....	10		
Parts List.....	11		

---



## Introduction

Congratulations on your purchase of a Champion Power Equipment Air Compressor. With proper use and maintenance, this air compressor will bring years of satisfying service.

### ***This Booklet***

Every effort has been made to ensure the accuracy and completeness of the information in this manual. We reserve the right to change, alter and/or improve the product and this document at any time without prior notice.

Record the model and serial numbers as well as date and place of purchase for future reference. Have this information available when ordering parts and when making technical or warranty inquiries.

<b>Champion Power Equipment Support</b>
1-877-338-0999
<b>Model Number</b>
30007
<b>Serial Number</b>
<b>Date of Purchase</b>
<b>Purchase Location</b>

# Manual Conventions

---

## Manual Conventions

This manual uses the following symbols to help differentiate between different kinds of information. The safety symbol is used with a key word to alert you to potential hazards in operating and owning power equipment.

Follow all safety messages to avoid or reduce the risk of serious injury or death.



### DANGER

DANGER indicates an imminently hazardous situation which, if not avoided, *will* result in death or serious injury.



### WARNING

WARNING indicates a potentially hazardous situation which, if not avoided, *could* result in death or serious injury.



### CAUTION

CAUTION indicates a potentially hazardous situation which, if not avoided, *may* result in minor or moderate injury.

### CAUTION

CAUTION used without the safety alert symbol indicates a potentially hazardous situation which, if not avoided, *may* result in property damage.



### NOTE

If you have questions regarding your air compressor, we can help. Please call our help line at 1-877-338-0999.

## Safety Rules

### WARNING

Read this manual thoroughly before operating your air compressor. Failure to follow instructions could result in serious injury or death.

### WARNING

Particulate Matter from user applications

Dust created by spraying, blowing, power sanding, sawing, grinding, drilling and other construction activities contains chemicals known to the state of California to cause cancer, birth defects or other reproductive harm. Reduce exposure to these chemicals by wearing approved safety equipment.

### DANGER

Risk of Tank Bursting

Do not adjust regulator to result in output pressure greater than marked maximum pressure of attachment. If a regulator has not been installed, use only attachment rated at 120 PSI or higher. Do not weld on or repair tank – A damaged tank must be replaced. Do not operate without proper valve connection.  
Never attempt to repair or make modifications to the tank or its attachments. Welding, drilling, or any other modifications may weaken the tank, which may result in damage from rupture or explosion.  
Never remove or attempt to adjust the pressure switch, safety valve or other components that control tank pressure.

### DANGER

Risk of Electrical Shock

Disconnect air compressor from power source before servicing. USE PROPERLY grounded ELECTRICAL CONNECTIONS — DO NOT use grounding adaptors. Do not use in wet or damp locations or expose to rain. Keep all connections dry and off the ground. Do not allow power cords to come into contact with water. Do not touch the plug with wet hands. Do not pull on the electrical cord to disconnect from the power outlet. Store air compressor indoors when not in use.

### WARNING

Do not inhale compressed air

This air compressor is not designed, nor intended for the supply of breathable quality air. Air produced by this unit may contain carbon monoxide or other toxic vapors. Do not inhale air from the compressor or from a breathing device connected to it.

### WARNING

Air Compressor generates significant heat

Touching exposed metal such as the compressor head or exhaust tube can result in serious burns. Keep hands and fingers away from exposed metal parts on air compressor during or immediately after operation. Air compressors generate significant heat during normal operation and will remain hot for some time after use.

# Safety Rules

---

## WARNING

Compressed air stream can be harmful to people or pets

The powerful compressed air stream can damage exposed skin and easily propel loose dirt, and other small objects at high-speed, resulting in injury. Always wear eye protection that meets ANSI Z28.1 specifications. Shut OFF air compressor and relieve pressure before performing maintenance or repairs. Do not move the air compressor while the air tank is pressurized. Never attempt to move the air compressor by pulling on the air hose.

## WARNING

Movement from Vibration

Always operate air compressor in a stable and secure position to prevent accidental movement of the unit. Never operate air compressor on a roof or other elevated position. Use additional air hose to reach high locations.

## WARNING

Air Tools and Accessories

Do not exceed the pressure rating of any air tools, spray guns, air accessories, or inflatables. Excess pressure can cause them to explode, resulting in serious injury. Follow the manufacturers recommended pressure settings for all air tools and air accessories.

## WARNING

Release air and liquid from tank before and after each use

Use the drain valve located on the bottom of the lower air tank to drain. Failure to properly drain liquid from the tank will cause rust from moisture buildup, which weakens the tank and could lead to a violent tank explosion. Periodically inspect the tanks for unsafe conditions such as corrosion, cracked welds, and leaks. When operating drain valve, release air and liquid slowly when depressurizing the tank. High speed release of air and liquid may stir up rust and debris and may result in injury.



## Controls and Features

Read this owner's manual before operating your air compressor. Familiarize yourself with the location and function of the controls and features. Save this manual for future reference.

### 13 gallon Air Compressor

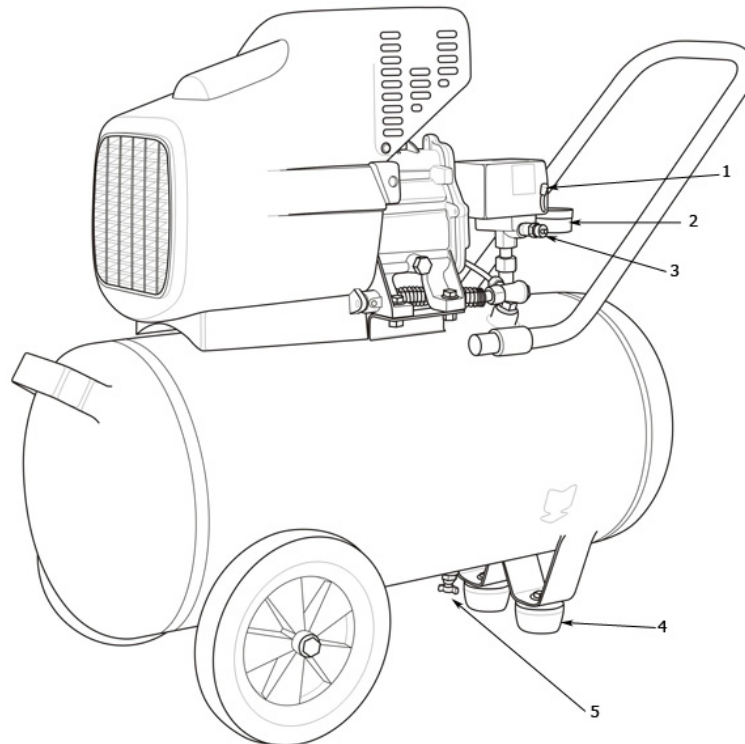

**(1) Motor Switch/Tank Regulator housing** – Control center tank pressure, On/Off switch

**(2) Tank Pressure Gauge** – Displays current tank pressure

**(3) Safety Relief Valve**- Plunger valve, engages when tank regulator fails. Releases tank pressure

**(4) Rubber feet** – to absorb compressor vibration

**(5) Safety Relief Valve**- Plunger valve, engages when tank regulator fails. Releases tank pressure

**Oil Breather Cap** – (not pictured) Fill oil here

**Pump housing** – (not pictured) Cast iron cylinder, oil lubricated

**Oil Level Sight Glass** – (not pictured) Verify pump oil level here

**Outlet port** – (not pictured) Quick connect coupler

**Outlet port pressure gauge**- (not pictured) Displays outlet port pressure

## Assembly

Your air compressor requires some assembly. This unit ships from our factory without oil. It must be properly serviced with oil before operation.

If you have any questions regarding the assembly of your air compressor, call our help line at 1-877-338-0999. Please have your serial number and model number available.

### Add Compressor Oil

#### CAUTION

DO NOT attempt to start the compressor before it has been properly filled with the recommended type and amount of oil. Damage to the compressor as a result of failure to follow these instructions will void your warranty.

**Use only SAE 30 Weight non-detergent air compressor oil**

1. Place the compressor on a flat, level surface.
2. Remove oil cap to add oil.
3. Use provided oil bottle and pour oil into crankcase until oil level reaches the center of the red circle in oil level sight glass. Do not overfill.

#### NOTE

Check oil often during the break-in period. Refer to the Maintenance section for recommended service intervals.

### Attach Air Filter

1. Locate air filter among packed items
2. Twist on air filter to upper side of motor housing. See figure (item 4) on previous page.

### Break-In Procedure

1. Please read and understand the entire owner's manual, including all safety warnings before operating air compressor.
2. Place air compressor on a flat, level surface.
3. Check oil level in crankcase via the Oil Sight glass and add oil as needed.
4. **Open** the tank drain valve to allow air to escape preventing air pressure buildup in the air tank.
5. Check that motor power switch is in OFF position, then plug in power cord into grounded outlet.
6. Turn compressor ON by moving switch lever to AUTO/ON position and run the compressor for 15 minutes. With the drain valve open, this will cause the motor to run continuously.
7. After about 15 minutes, with the motor still running, close the tank drain valve. This will allow the tank to build pressure and automatically shut off once the tank hits the maximum pressure. Notice tank pressure gauge (125psi)
8. Slowly re-open the tank drain valve to release air from tank. As the tank pressure drops, the motor/pump will automatically restart as it hits the minimum preset pressure.
9. Turn compressor off by moving switch lever to off position
10. Release residual pressure from tanks by slowly opening air tank drain valve
11. Tilt tank to remove any moisture that may remain in tank. Once completed, close the valve securely.
12. Unplug compressor from power outlet
13. Your new Champion Air Compressor is now ready to use

# Operation

---

## Operation

### **Start Up Procedure**

1. Before plugging compressor into power outlet, make sure motor switch is in the OFF position.
2. Place air compressor on a flat, level surface.
3. Check oil level in crankcase via the Oil Sight glass and add oil as needed.
4. Drain moisture from the air tank by slowly opening the air tank drain valve by turning clockwise. Once all the moisture has drained out, close the fitting securely
5. Turn output port regulator knob to a closed position (counterclockwise)
6. Attach air hose and accessories.
7. Before plugging compressor into power outlet check to see all components, hoses, accessories, are all in working order.
8. Plug power cord directly into a properly grounded power source of the correct voltage
9. Turn the compressor ON by moving the motor switch to the AUTO/ON position.

Allow the tank pressure to build. Once the air pressure reaches the preset pressure maximum it will automatically shut off.

10. Adjust regulator knob on outlet port to appropriate pressure for particular accessory

### **Shutdown and Storage**

1. Turn the switch to the OFF position
2. Unplug compressor from power source
3. Turn the outlet pressure regulator knob fully counterclockwise to close airflow to port. Check pressure gauge that it reads 0 PSI
4. Remove air hose and any accessories
5. Slowly open tank drain valve to release moisture from tanks. Tilt tank to remove all moisture. When all moisture has been removed, close the fitting securely.
6. Allow the compressor motor to cool down
7. Wipe down and store in a clean, dry, and non-freezing location

# Maintenance

---

## Maintenance

The owner/operator is responsible for all periodic maintenance.



### WARNING

Improper maintenance will void your warranty.

Complete all scheduled maintenance in a timely manner. Correct any issue before operating the air compressor.



### NOTE

For service or parts assistance, contact our toll-free help line at 1-877-338-0999.

## Compressor Maintenance

### Oil Change

Change oil when the engine is cool.

1. Remove the oil drain plug with a 15 mm socket and extension.
2. Allow the oil to drain completely.
3. Replace the drain plug.
4. Remove oil fill cap to add oil.
5. **Add Only SAE Weight 30 non-detergent air compressor oil.** Refer to oil level sight glass for proper fill level.
6. Dispose of used oil at an approved waste management facility.

### Checking Safety Relief Valve

1. Turn air compressor off and disconnect from power source
2. Release tank pressure by opening tank drain
3. Allow compressor to fully cool
4. Grasp wire ring on safety relief valve and pull and release the ring a few times to verify plunger movement
5. Replace safety relief valve if plunger is not functional

### Air Filter

1. Turn off air compressor and disconnect from power source
2. Release tank pressure by opening tank drain
3. Allow compressor to fully cool
4. Unscrew wing on filter body cover to access the filter element.
5. Remove filter element. Use compressed air to blow loose dirt and debris. Replace filter element if it cannot be cleaned sufficiently.
6. Reinstall filter element and reattach cover to filter body

### Maintenance Schedule

Follow the service intervals indicated in the schedule below.

Service your air compressor more frequently when operating in adverse conditions.

Every 8 hours or daily
Check oil level
First 20 Hours
Change oil
Every 200 hours or every 6 months
Change oil
Change oil more frequently if using in dusty environments

6.

# Specifications

---

## Specifications

### **13 Gallon Portable Air Compressor**

Volt	120V/60Hz
Pump	Oil Lubricated Direct Drive
Air Displacement	4.3CFM @ 40psi 3.5CFM @ 90psi
Max Pressure	115 PSI
Power	3HP max 2HP running
Motor Speed	3450 RPM
Tank Size	13 gallon
Rated Electricity	15 Amps

# Specifications

## Parts Diagram

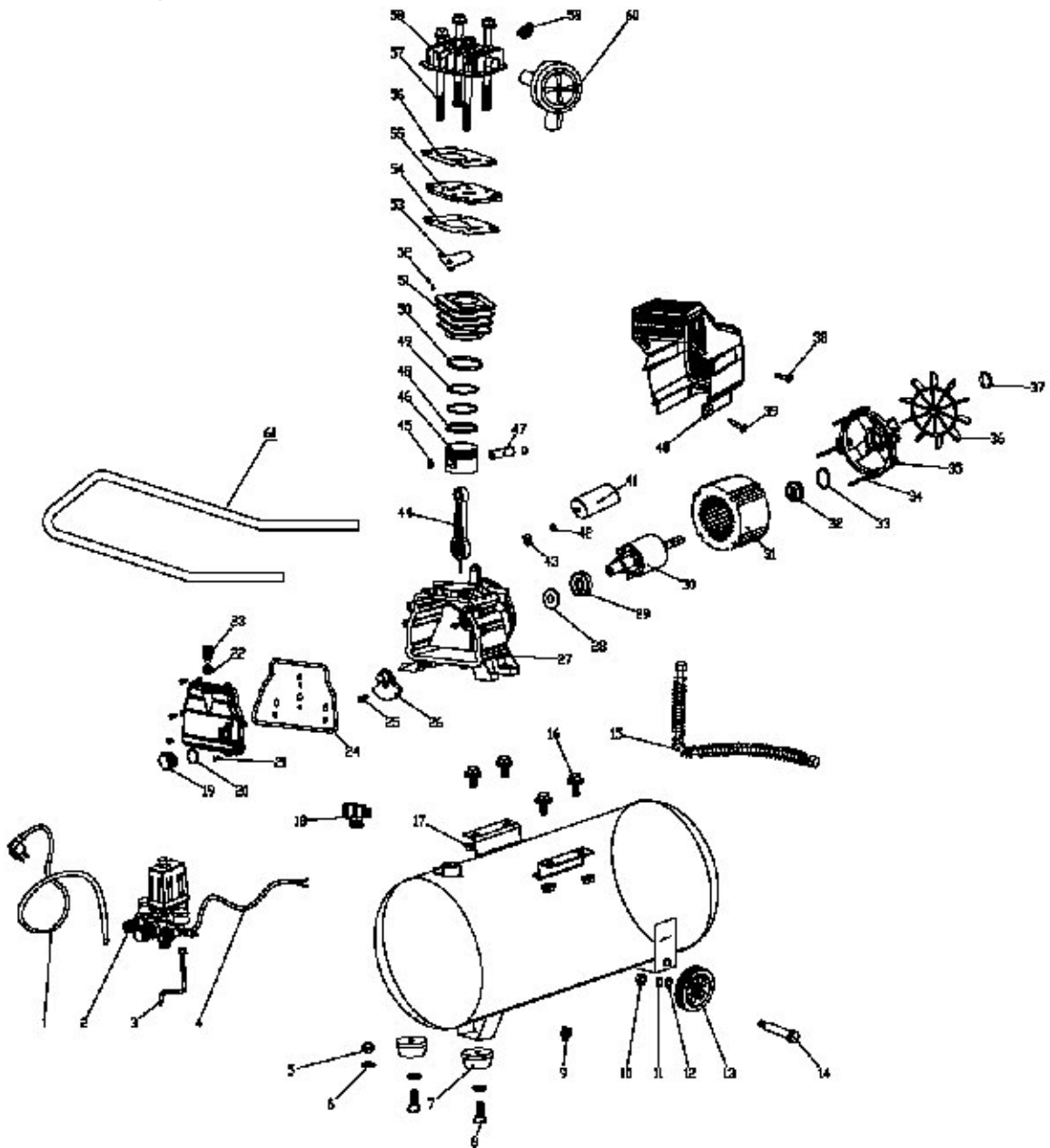

## Parts List

No	Part Number	Description	Qty
1	30007-01	power cord	1
2	30007-02	pressure switch	1
3	30007-03	release pipe	1
4	30007-04	motor cord	1
5	30007-05	nut M8	1
6	30007-06	washer 10	1
7	30007-07	washer foot	1
8	30007-08	bolt M8*25	1
9	30007-09	drain cock	1
10	30007-10	nut M10	2
11	30007-11	spring washer 10	2
12	30007-12	washer 10	2
13	30007-13	rubber wheel	2
14	30007-14	wheel axes	2
15	30007-15	discharge pipe	1
16	30007-16	bolt M8*20	4
17	30007-17	nut M8	4
18	30007-18	only-way valve	1
19	30007-19	oil leveler	1
20	30007-20	oil leveler washer	1
21	30007-21	bolt M5*14	6
22	30007-22	breath pipe washer	1
23	30007-23	breath pipe	1
24	30007-24	rubber gasket	1
25	30007-25	bolt M5*25	1
26	30007-26	crank	1
27	30007-27	crankcase	1
28	30007-28	sealing ring	1
29	30007-29	bearing 6204	1
30	30007-30	rotor	1
31	30007-31	stator	1
32	30007-32	bearing 6202	1
33	30007-33	corrugate washer	1
34	30007-34	bolt M5*105	4
35	30007-35	motor bracket	1
36	30007-36	fan	1
37	30007-37	circlip	1
38	30007-38	bolt M5*8	2
39	30007-39	bolt	2
40	30007-40	fan cover	1
41	30007-41	capacitance	1
42	30007-42	circlip	1
43	30007-43	nut M8	1
44	30007-44	connecting rod	1
45	30007-45	circlip	2
46	30007-46	piston	1
47	30007-47	piston pin	1
48	30007-48	oil ring	1
49	30007-49	gas ring	2
50	30007-50	cylinder gasket	1
51	30007-51	cylinder	1
52	30007-52	valve clack pin	2
53	30007-53	valve clack	1
54	30007-54	valve plate gasket	1
55	30007-55	valve plate	1

# Specifications

---

No	Part Number	Description	Qty
56	30007-56	cylinder head gasket	1
57	30007-57	bolt M8*103	4
58	30007-58	cylinder head	1
59	30007-59	right-angle connector	1
60	30007-60	air filter	1
61	30007-61	steel hand	1



## Troubleshooting

Problem	Cause	Solution
Air Compressor will not start	Power cord	Plug into grounded outlet
	Motor Switch is in OFF position	Move lever to auto/on position
	Blown fuse, circuit breaker trip	Replace fuse, reset circuit breaker Unplug other appliances from same outlet
	Wrong gauge extension cord	Check gauge on cord and verify that it is the correct size
	Tank pressure is greater than auto motor "kick in"	Open tank drain valve to release tank pressure
	Defective motor, motor switch	Call Champion Hotline #
Overheating	Insufficient Ventilation	Place compressor in environment with well circulated supply of cool, dry air.
	Dirty or obstructed cooling fins	Clean surfaces of cooling fins on and around pump/motor area
When in Auto/On position, motor runs continuously	Motor switch malfunction- does not respond when tank reaches max pressure, safety relief valve engage	Move motor switch to OFF position. If motor does not shut-off, unplug the compressor. Evaluate motor switch wiring. Replace if needed
	Incorrect compressor size for tool application	The Air tool might be too big for the compressor you are using. Use a smaller air tool, or a larger compressor
Air leak after motor stops at switch release valve	The check valve is stuck open	Remove, clean or replace check valve
Air leak while motor is running at switch release valve	Defective motor switch	Replace
	The check valve is stuck open	Replace- NOTE – do not remove while tank is pressurized. Release tank pressure by opening tank drain valve
Air leak from safety relief valve	Malfunctioning safety relief valve	Pull manually on ring. If valve does not make a clean seal when closed, replace.
	Excessive Tank Pressure	Defective motor switch. Replace
Air leaks at pump	Malfunctioning/blown gaskets	Replace poor gaskets
Air leaks in tank	Rusted, broken welds – Defective tank	Replace – Note – <b>Do not attempt to repair air tank!</b>
Air leaks at fittings	Fittings are not sufficiently tight	Tighten fittings – Note- Do not over tighten
Air blowing from intake filter	Damage intake valve	Contact Champion Hotline #
Insufficient pressure for air tool or accessory	Air leaks	Check for leaks on all fittings and connections. Tighten or repair connections as needed
	Air compressor is not large enough for particular air equipment	Note the equipment requirement – if higher than pressure supply of compressor, or causes the motor to run continuously, you need a larger air compressor
	Pressure regulator is not set to accurate pressure	Adjust pressure regulator knob to correct setting
	Restricted air intake	Clean or replace filter element
	Defective motor/pressure switch	Replace
	Hose or hose connection(s) are inaccurate size	Assess and replace if necessary
Air compressor not making enough air	Low compression	Possible worn piston rings and/or cylinder walls. Inspect and replace as needed
	Malfunctioning intake filter	Clean or replace filter element
	Leaking inlet valve	Release all tank pressure, then measure pump up time. Compare to

# Troubleshooting

---

<b>Problem</b>	<b>Cause</b>	<b>Solution</b>
		specifications. If needed inspect and replace valve components
	Malfunctioning pilot valve	Clean or replace
Moisture in discharge air	Excessive condensation in air tank due to atmospheric humidity	Always drain tank after use. Drain more often in areas of high humidity. Use air line filter

## Warranty

### CHAMPION POWER EQUIPMENT 1 YEAR LIMITED WARRANTY

#### **Warranty Qualifications**

Champion Power Equipment (CPE) will register this warranty upon receipt of your Warranty Registration Card and a copy of your sales receipt from one of CPE's retail locations as proof of purchase.

Please submit your warranty registration and your proof of purchase within ten (10) days of the date of purchase.

#### **Repair/Replacement Warranty**

CPE warrants to the original purchaser that the mechanical and electrical components will be free of defects in material and workmanship for a period of one (1) year from the original date of purchase (90 days for commercial & industrial use). Transportation charges on product submitted for repair or replacement under this warranty are the sole responsibility of the purchaser. This warranty only applies to the original purchaser and is not transferable.

#### **Do not return the unit to the place of purchase**

Contact CPE's Technical Service and CPE will troubleshoot any issue via phone or e-mail. If the problem is not corrected by this method, CPE will, at its option, authorize evaluation, repair or replacement of the defective part or component at a CPE Service Center. CPE will provide you with a case number for warranty service. Please keep it for future reference. Repairs or replacements without prior authorization, or at an unauthorized repair facility, will not be covered by this warranty.

#### **Warranty Exclusions**

This warranty does not cover the following repairs and equipment:

##### **Normal Wear**

Compressors need periodic parts and service to perform well. This warranty does not cover repair when normal use has exhausted the life of a part or the equipment as a whole.

##### **Installation, Use and Maintenance**

This warranty will not apply to parts and/or labor if this compressor is deemed to have been misused, neglected, involved in an accident, abused, pressurized beyond the recommended pressure or temperature limits, modified, installed improperly or connected incorrectly to

any electrical component. Failure to follow recommended operating and maintenance procedure will also void this warranty.

#### **Other Exclusions**

This warranty excludes:

Cosmetic defects such as paint, decals, etc.  
Pump or valve failure due to rain, excessive humidity, corrosive environments or other contaminants; rusted tanks including but not limited to rust due to improper drainage or corrosive environments.

Failures to due acts of God and other force majeure events beyond the manufacturer's control.

Problems caused by parts that are not original Champion Power Equipment parts.

This warranty does not apply to compressors used for commercial or rental purposes.

#### **Limits of Implied Warranty and Consequential Damage**

Champion Power Equipment disclaims any obligation to cover any loss of time, use of this product, freight, or any incidental or consequential claim by anyone from using this compressor. THIS WARRANTY IS IN LIEU OF ALL OTHER WARRANTIES, EXPRESS OR IMPLIED, INCLUDING WARRANTIES OF MERCHANTABILITY OR FITNESS FOR A PARTICULAR PURPOSE

A unit provided as an exchange will be subject to the warranty of the original unit. The length of the warranty governing the exchanged unit will remain calculated by reference to the purchase date of the original unit.

This warranty gives you certain legal rights which may change from state to state. Your state may also have other rights you may be entitled to that are not listed within this warranty.

#### **Contact Information**

##### **Address**

Champion Power Equipment, Inc.  
Customer Service  
10006 Santa Fe Springs Rd.  
Santa Fe Springs, CA 90670

##### **Customer Service**

Mon – Fri 8:30 AM – 5:00 PM (PST/PDT)  
Toll Free: 1-877-338-0999  
Fax no.: 1-562-236-9429

##### **Technical Service**

Mon – Fri 8:30 AM – 5:00 PM (PST/PDT)  
Toll Free: 1-877-338-0999  
tech@championpowerequipment.com

Notes

---

Notes