

CHAMPION

POWER EQUIPMENT

TM-MC

OPERATOR'S MANUAL



3,500 lb. (1,588 kg) SYNTHETIC ROPE WINCH KIT



Model number

100428

SAVE THESE INSTRUCTIONS
Important safety instructions
are included in this manual.

MADE IN CHINA
REV 100428-20180731

12039 Smith Ave.
Santa Fe Springs CA 90670
USA / 1-877-338-0999
www.championpowerequipment.com

Have questions or need assistance?

Do not return this product to the store!

WE ARE HERE TO HELP!

Visit our website:

www.championpowerequipment.com

for more info:

- Product Info & Updates
- Tech Bulletins
- Frequently Asked Questions
- Product Registration

– or –

Call our Customer Care Team Toll-Free at:

1-877-338-0999

Parts Ordering:

Mon – Fri 8:30 AM – 5:00 PM (PST/PDT)

Toll Free: 1-877-338-0999

*We are always working to improve our products. Therefore, the enclosed product may differ slightly from the image on the cover.

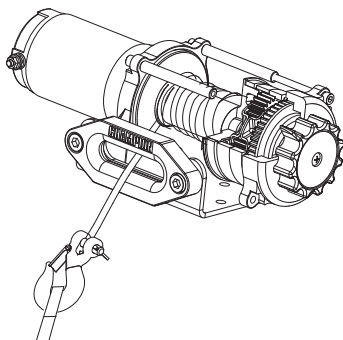

3,500 lb. (1,588 kg) SYNTHETIC ROPE WINCH KIT

TABLE OF CONTENTS

Introduction	1	Maintenance	12
Manual Conventions	2	Lubrication	12
Safety Rules	3	Cable Assembly Replacement	12
Controls and Features	5	Synthetic Rope Replacement	12
Winch	5	Synthetic Rope	12
Assembly	6	Troubleshooting	13
Mounting the Winch	6	Specifications	14
Mounting the Remote control	6	Performance Specifications	14
Winch Wiring	7	Parts Diagram	15
Wiring Diagram	8	Parts List	16
Operation	9		
General Tips for Safe Operation	9		
Self Recovery	9		
Winching Techniques A-Z	11		

INTRODUCTION

Congratulations on your purchase of a Champion Power Equipment (CPE) product. CPE designs, builds, and supports all of our products to strict specifications and guidelines. With proper product knowledge, safe use, and regular maintenance, this product should bring years of satisfying service.

Every effort has been made to ensure the accuracy and completeness of the information in this manual, and we reserve the right to change, alter and/or improve the product and this document at any time without prior notice.

Since CPE highly values how our products are designed, manufactured, operated and serviced, and also highly value your safety and the safety of others, we would like you to take the time to review this product manual and other product materials thoroughly and be fully aware and knowledgeable of the assembly, operation, dangers and maintenance of the product before use. Fully familiarize yourself, and make sure others who plan on operating the product fully familiarize themselves too, with the proper safety and operation procedures before each use. Please always exercise common sense and always err on the side of caution when operating the product to ensure no accidents, property damage, or injury occurs. We want you to continue to use and be satisfied with your CPE product for years to come.

Record the model and serial numbers as well as date and place of purchase for future reference. Have this information available when ordering parts and when making technical or warranty inquiries.

Champion Power Equipment Support
1-877-338-0999
Model Number
100428
Serial Number
Date of Purchase
Purchase Location

This manual uses the following symbols to help differentiate between different kinds of information. The safety symbol is used with a keyword to alert you to potential hazards in operating and owning power equipment.

Follow all safety messages to avoid or reduce the risk of serious injury or death.

 **DANGER**

DANGER indicates an imminently hazardous situation which, if not avoided, **will** result in death or serious injury.

 **WARNING**

WARNING indicates a potentially hazardous situation which, if not avoided, **could** result in death or serious injury.

 **CAUTION**

CAUTION indicates a potentially hazardous situation which, if not avoided, **may** result in minor or moderate injury.

CAUTION

CAUTION used without the safety alert symbol indicates a potentially hazardous situation which, if not avoided, **may** result in property damage.

 **NOTICE**

If you have questions regarding your winch, we can help. Please call our help line at **1-877-338-0999**.

SAFETY RULES

 **WARNING**

Read this manual thoroughly before operating your winch. Failure to follow instructions could result in serious injury or death.

 **WARNING**

Cancer and Reproductive Harm –
www.P65Warnings.ca.gov

 **WARNING**

Do not exceed the rated capacity.

 **DANGER**

Do not use this winch for lifting or moving people or animals.

 **DANGER**

Keep yourself and others a safe distance to the side of the cable when under tension.

 **DANGER**

Never step over a cable or near a cable under load.

 **WARNING**

The synthetic rope may break before the motor stalls. For heavy loads at or near rated capacity, use a pulley block/snatch block to reduce the load on the synthetic rope.

 **WARNING**

Do not move the vehicle to pull a load (towing) on the winch cable. This could result in cable breakage.

 **WARNING**

Pull only on areas of the vehicle as specified by the vehicle manufacturer.

 **WARNING**

Do not use the winch to secure or hold a vehicle for a long period of time. Do not use the winch to secure a vehicle for transport.

 **WARNING**

Disconnect the remote control and battery leads when not in use.

 **WARNING**

Avoid “shock loads” by using the control switch intermittently to take up the slack in the synthetic rope. “Shock loads” can far exceed the rate capacity for the synthetic rope and drum.

Do not accelerate your vehicle while winching. Loss of traction can cause a shock load on the cable.

 **WARNING**

Batteries contain acid and produce explosive gases.

Keep sparks, flames and cigarettes away from batteries at all times. Wear safety glasses and protect the eyes at all times. Do not lean over the batteries during operation.

⚠ WARNING

When re-spooling the cable, ensure that the cable spools in the under-wind position with the cable entering the drum from the bottom, not the top.

To re-spool correctly, and while wearing gloves, keep a slight load on the cable while pushing the remote button to draw in the cable. Walk toward the winch and do not allow the cable to slide through your hands. Do not let your hands get within 12 in. (30 cm) of the winch while re-spooling. Turn off the winch and repeat the procedure until a few feet of cable are left. Disconnect the remote control and finish spooling by rotating the drum by hand with the clutch disengaged. Keep hands clear of the fairlead and drum while the winch is under power .

⚠ WARNING

Do not use as a hoist. Do not use for overhead lifting.

⚠ CAUTION

Use gloves to protect hands when handling the cable. Never let the cable slide through your hands.

⚠ CAUTION

Do not wrap the cable around any object and hook it back onto itself.

⚠ CAUTION

Apply blocks to the wheels of the vehicle when on an incline.

⚠ CAUTION

Duration of winching pulls should be kept as short as possible.

If the motor becomes uncomfortably hot to the touch, stop winching immediately and let it cool down for a few minutes. Do not pull for more than one minute at or near the rated load.

⚠ CAUTION

If the motor stalls, do not maintain power to the winch.

Electric winches are designed and made for intermittent use and should not be used in constant duty applications.

⚠ CAUTION

Never release the free-spool clutch when there is a load on the winch.

⚠ CAUTION

Use hook strap when handling the hook for spooling or unspooling the synthetic rope.

CONTROLS AND FEATURES

Read this owner's manual before operating your winch. Familiarize yourself with the location and function of the controls and features. Save this manual for future reference.

Winch

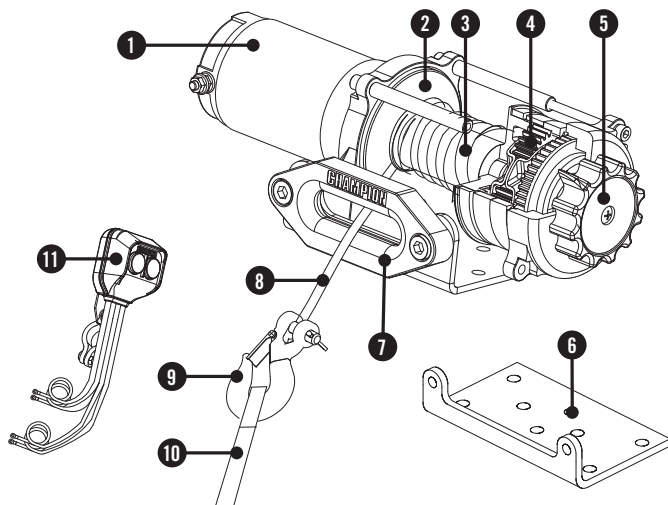

- (1) **Motor** - 1.4 HP 12V DC motor provides power to the planetary gear mechanism.
- (2) **Braking System** - Braking action is automatically applied to the winch drum when the winch motor is stopped and there is a load on the synthetic rope.
- (3) **Winch Drum** - The winch drum is the cylinder on which the synthetic rope is stored. It can feed or wind the rope depending on the remote winch switch.
- (4) **Planetary Gear System** - The reduction gears convert the winch motor power into extreme pulling forces. This system allows high torque while maintaining compact size and light weight.
- (5) **Free Spooling Clutch** - The clutch allows the operator to manually disengage ("Out") the spooling drum from the gear train, free spool. Engaging the clutch ("In") locks the winch into the gear system.
- (6) **Mounting Channel**
- (7) **Aluminum Hawse Fairlead** - When using the winch at an angle the hawse acts to guide the synthetic rope onto the drum and minimizes damage to the synthetic rope from abrasion on the winch mount or bumper.
- (8) **Synthetic Rope** - Synthetic rope designed specifically for load capacity of 3,500 lb.(1,588 kg). The synthetic rope feeds onto the drum in the "under wind" position through the aluminum hawse and is looped at the end to accept the clevis hook pin.
- (9) **Clevis Hook** - Provides a means for connecting the looped ends of cables to an anchor.
- (10) **Strap** - Used to assist cable feed.
- (11) **Control Switch** - Rocker switch with handlebar mount for powering the rope in or out of your winch drum.

Mounting the Winch

This CPE 1,588 kg (3,500 lb.) winch is designed with a bolt pattern that is standard in this class of winch. Many winch mounting kits are available that utilize this bolt pattern for the most popular ATVs and UTVs. If you cannot find a kit locally, contact CPE and we will provide you with the name of a dealer.

! CAUTION

Mounting bolts must be SAE grade 5 or better and torque to 34 ft. lb.

1. Insert two (2) M10x25 bolts to the mounting channel hole and attach the aluminum hawse to the mounting channel with the two (2) M10 nut provided. (A)

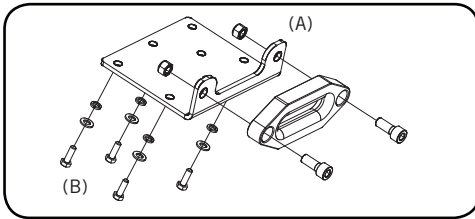

2. Turn the winch upside down. Place the mounting channel on the winch, making sure the winch is centred in the middle of it.
3. Thread the M8x25 bolts through the M8 flat and lockers washers, and then thread through the mounting channel. Tighten the bolts. DO NOT over tighten. (B)
4. Turn winch right side up. Disengage the clutch by moving the Cam Ring to the "Out" position. Release the synthetic rope and pull through the aluminum hawse.
5. Attach the clevis hook to the cable, and then hand strap to the clevis hook.

Mounting the Winch Cont'd.

CAUTION

If utilizing a mounting plate, ensure that the three major sections (motor, drum and gear housing) are properly aligned. Proper alignment of the winch will allow for even distribution of the full rated load.

NOTE

The type of vehicle to which the winch and mounting channel will be applied, will dictate the type of mounting kit that should be used (Speed Mount Hitch Adapter, Standard Mounting Channel, or Specialty Mounting Kit).

Mounting the Control Switch

1. The control switch is usually installed on the left handlebar.
2. Use a piece of electrical tape around the handlebar to help prevent rotation of the mount on the handlebar. Do NOT tighten over any hoses or cables.
3. Once the control switch is mounted you can route the wires back to the battery and winch.
4. Make sure the handlebars have full range of motion and then secure the control switch's cable.

ASSEMBLY

Winch Wiring

! CAUTION

Never route electrical cables across any sharp edges, through or near moving parts, or near parts that become hot.

1. Connect the battery leads. **FOR WINCH TO FUNCTION PROPERLY:** Connect the red (+) lead of the remote to the red (+) terminal of the vehicle's 12 volt battery. Connect the black (-) lead of the remote to the black (-) terminal of the vehicle's 12 volt battery.
2. Attach the remote lead to the winch and test for proper operation.
3. Check for proper drum rotation. Pull and turn the clutch knob to the "out" position (Free spooling). Pull out some cable from the drum, and then turn the clutch knob to the "In" position to engage the gears. Press the cable out button on the switch. If the drum is turning and releasing more cable then your connections are accurate. If the drum is turning and collecting more cable then reverse the leads on the motor. Repeat and check rotation.

! CAUTION

Battery cables should not be drawn taut. Leave some slack for cable movement.

Winch Wiring Cont'd.

With some applications the motor leads may need to be rotated to avoid interference with other components.

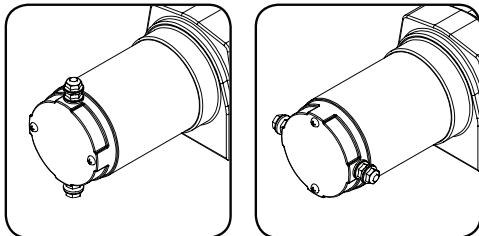

Wiring Diagram

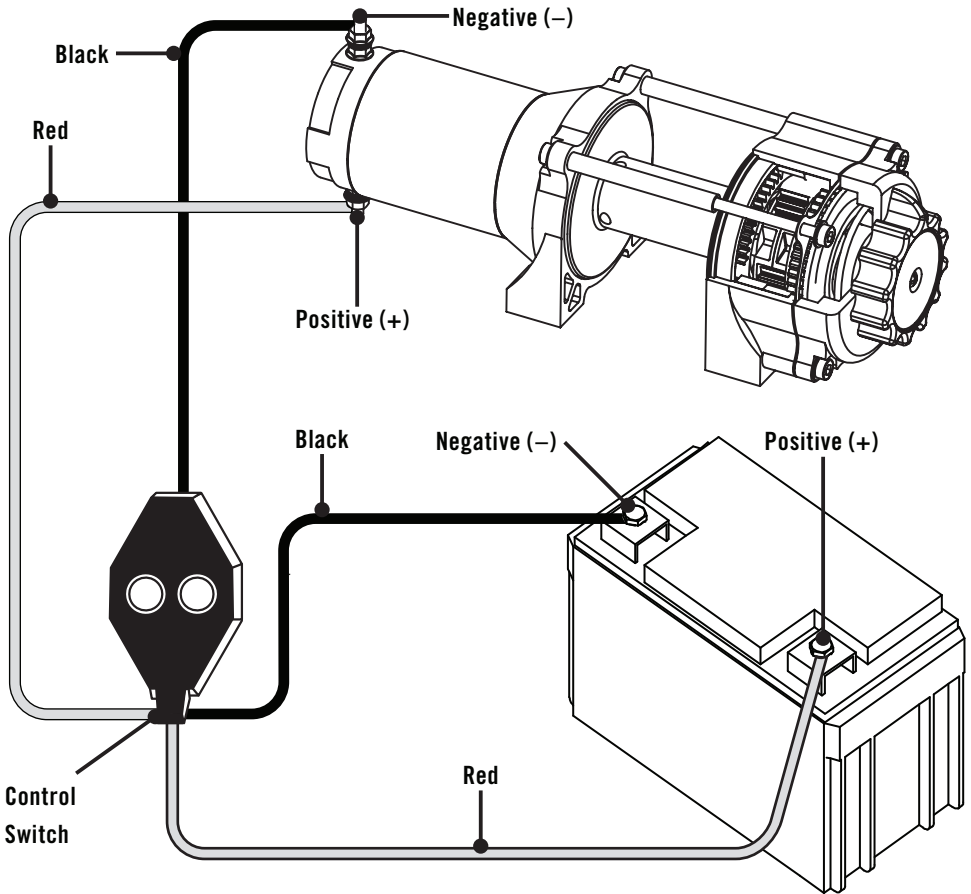

OPERATION

General Tips for Safe Operation

Overloads can damage the winch, motor and/or rope. In some cases, you may find yourself needing more pulling power. For loads over 50% winch rating when spooling on the first rope layer we recommend the use of the pulley/snatch block to double the synthetic rope line. The use of the pulley/snatch block increases mechanical advantage and will:

- Effectively double winching power
- Reduce the number of rope layers on the drum, and
- Reduce the load on the rope by as much as 50%

To review Line Pull and Cable Capacity please refer to Specifications Section found within the manual.

When doubling the line back to the vehicle, attach to the tow hook, frame or other load-bearing part. The vehicle engine should be kept running during operation of the winch to minimize battery drain and maximize power and speed of the winch. If the winch is used for a considerable time with the engine off the battery may be drained and too weak to restart the motor.

Get to know your winch before you actually need to use it. We recommend that you set up a few test runs to familiarize yourself with rigging techniques, the sounds your winch makes under various loads, the way the cable spools on the drum, etc.

Inspect the synthetic rope and equipment before each use. A frayed or damaged rope should be replaced immediately. Use only manufacturer's identical replacement rope with the exact specifications.

Inspect the winch installation and bolts to ensure that all bolts are tight before each operation. Store the remote control inside your vehicle in a place where it will not be damaged.

Any winch that appears to be damaged in any way, is found to be worn, or operates abnormally **MUST BE REMOVED FROM SERVICE UNTIL**

General Tips for Safe Operation Cont'd.

REPAIRED. It is recommended that the necessary repairs be made by a manufacturer's authorized repair facility.

Pull only on areas of the vehicle as specified by the vehicle manufacturer. Only attachments and/or adapters supplied by the manufacturer are to be used.

Self Recovery

Locate a suitable anchor such as a strong tree trunk or boulder. Always use a sling as an anchor point.

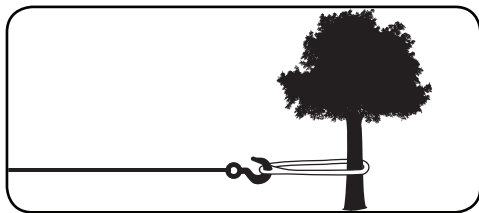

Your winch is equipped with an aluminum hawse to help guide the synthetic rope and to reduce binding on short side pulls. Do not winch from an acute angle as the synthetic rope will pile up on one side of the drum causing damage to synthetic rope and the winch.

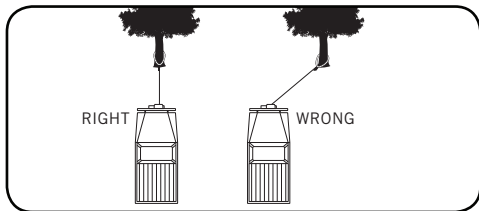

Short pulls from an angle can be used to straighten the vehicle. Long pulls should be done with the synthetic rope at a 90° angle to the winch/vehicle.

When pulling a heavy load, place a blanket or jacket over the synthetic rope 5 to 6 ft. (1.5 to 1.8 m) from the hook.

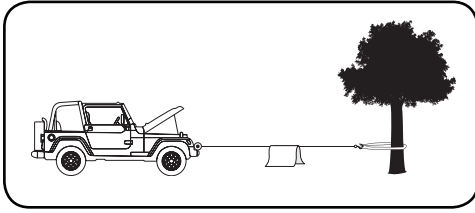
Self Recovery Cont'd.

In the event of a broken cable it will dampen the snap back. For additional protection open the hood of the vehicle. For loads over 50% winch rating when spooling on first rope layer, we recommend the use of the snatch block/pulley block (included) to double line the synthetic rope.

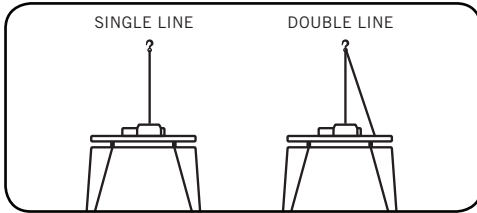

This reduces the load on the winch and the strain on the rope by approximately 50%.

OPERATION

Winching Techniques A-Z

- (a) Take time to assess your situation and plan your pull.
- (b) Put on gloves to protect your hands.
- (c) Disengage the clutch to allow free-spooling and also save battery power.
- (d) Attach the hook strap to the clevis hook.
- (e) Pull out the synthetic rope to your desired anchor point using the hook strap.
- (f) Secure the clevis hook to the anchor point: sling, chain or snatch block. Do not attach the hook back onto the synthetic rope.
- (g) Engage the clutch.
- (h) Connect the remote control to the winch. If you are going to control the winch from inside your vehicle, then pass the remote through an open window to avoid the wires being pinched in the door.
- (i) Start your engine to ensure power is being replenished to the battery.
- (j) Drape a blanket or jacket over the synthetic rope approximately 5 ft. - 6 ft. (1.5 m - 1.8 m) from the hook. Open the hood for added protection.
- (k) Power in the synthetic rope guiding the wire under tension to draw up the slack in the wire. Once the wire is under tension, stand clear. Never step over the synthetic rope.
- (l) Double check your anchors and make sure all connections are secure.
- (m) Inspect the synthetic rope. Make sure there are at least 5 wraps of synthetic rope around the winch drum.
- (n) Clear the area. Make sure all spectators stand clear and that no one is directly in front or behind the vehicle or anchor point.

Winching Techniques A-Z Cont'd.

- (o) Begin winching. Be sure that the synthetic rope is winding evenly and tightly around the drum. The vehicle that is being winched can be slowly driven to add assistance to the winching process. Avoid shock loads; keep the synthetic rope under tension.
- (p) The vehicle to be winched should be placed in neutral and the emergency brake released. Only release the brake pedal when under full tension. Avoid shock loads to the winch. This can damage the winch, rope and vehicle.
- (q) The winch is meant for intermittent use. Under full load with a single-line rig, do not power in for more than a minute without letting the motor cool down for a few minutes and then resume the winching operation.
- (r) The winching operation is complete once the vehicle is on stable ground and is able to drive under its own power.
- (s) Secure the vehicle. Be sure to set the brakes and place the vehicle in park.
- (t) Release the tension on the synthetic rope. The winch is not meant to hold the vehicle for long periods of time.
- (u) Disconnect the synthetic rope from the anchor.
- (v) Rewind the synthetic rope. Make sure that any wire already on the drum has spooled tightly and neatly. If not, draw out the wire and re-spool from the point where the rope is tight.
- (w) Keep your hands clear of the winch drum and fairlead as the synthetic rope is being drawn in.
- (x) Secure the hook and hook strap.
- (y) Disconnect the remote control and store in a clean, dry place.
- (z) Clean and inspect connections and mounting hardware for next winching operation.

The owner/operator is responsible for all periodic maintenance.

WARNING

Never operate a damaged or defective winch.

WARNING

Improper maintenance will void your warranty.

Complete all scheduled maintenance in a timely manner. Correct any issue before operating the winch.

NOTICE

For service or parts assistance, contact our help line at **1-877-338-0999**.

Lubrication

All moving parts within the electric winch have been lubricated using high-temperature lithium grease at the factory. No internal lubrication is required.

Cable Assembly Replacement

It is recommended that any modifications be performed by a manufacturer's authorized repair facility, and that only manufacturer-supplied parts be used.

1. Move the clutch to the "Out" position.
2. Extend cable assembly to its full length. Note how the existing cable is connected to the inside of the drum.
3. Remove old cable assembly and attach new one.
4. Retract cable assembly onto drum, being careful not to allow kinking.

Synthetic Rope Replacement

It is recommended that any modifications be performed by a manufacturer's authorized repair facility, and that only manufacturer-supplied parts be used.

1. Move the clutch to the "Out" position.
2. Extend synthetic rope to its full length. Note how the existing rope is connected to the inside of the drum.
3. Remove old synthetic rope and attach new one.
4. Retract synthetic rope onto drum being careful not to allow kinking.

Synthetic Rope

Periodically rinse the synthetic rope with water to remove any sand, dirt, mud, or debris that can become embedded or build up in the rope during use. This will help extend the life of the rope.

NOTE

Inspect rope before and after each use. If rope becomes frayed it must be replaced.

TROUBLESHOOTING

Problem	Cause	Solution
Motor does not turn on	Switch assembly not connected properly.	Insert switch assembly all the way into the connector.
	Loose battery cable connections.	Tighten nuts on all cable connections.
	Contactors malfunctioning.	Tap contactor to loosen contacts. Apply 12 volts to coil terminals directly. A clicking indicates proper activation.
	Defective switch assembly.	Replace switch assembly.
	Defective motor.	Check for voltage at armature port with switch pressed. If voltage is present, replace motor.
	Water has entered motor.	Allow to drain and dry. Run in short bursts without load until completely dry.
Motor runs but cable drum does not turn	Clutch (cam ring) not engaged.	Move cam ring to the "In" position. If problem persists, a qualified technician needs to check and repair.
Motor runs slowly or without normal power	Insufficient current or voltage.	The battery is weak; recharge. Run winch with vehicle motor running (battery should have a strong charge).
	Loose or corroded battery cable connections.	Clean, tighten, or replace.
Motor overheating	Winch running time too long.	Allow winch to cool down periodically.
Motor runs in one direction only	Defective or stuck contactor	Tap contactor to loosen contacts
		Repair or replace contactor
	Defective switch assembly	Replace switch assembly

For further technical support:

Technical Service

Mon – Fri 8:30 AM – 5:00 PM (PST/PDT)

Toll Free: 1-877-338-0999

tech@championpowerequipment.com

Performance Specifications

- Rated Pull 3,500 lb. (1,588 kg)
- Gear Reduction Ratio 171:1
- Motor Permanent Magnet 1.4 HP/1.0 kW (12V DC)
- Duty Cycle Intermittent Use Only
- Drum Size 1.5 in. (D) × 3.2 in. (L) [38 mm (D) × 80 mm (L)]
- Synthetic Rope 3/16 in. (D) × 50 ft. (L) [4.8 mm (D) × 15.2 m (L)]
- Gross Weight 20.5 lb (9.3 kg)
- Net Weight 18.3 lb (8.3 kg)
- Height 4.2 in. (10.7 cm)
- Width 4.1 in. (10.3 cm)
- Length 13.0 in. (32.9 cm)
- Bolt Pattern 4.9 in. × 3 in. (12.4 cm × 7.6 cm)

Line Speed and Motor Current (First Layer)							
Line Pull	lb.	0	1000	1500	2000	2500	3500
	kg.	0	454	680	907	1134	1588
Line Speed (12V DC)	FPM	9.8	8.5	7.2	6.2	5.9	3.3
	MPM	3.0	2.6	2.2	1.9	1.8	1.0
Max Current	A	18	70	100	130	165	230
Run Time*	Minutes	1	1	1	1	1	1
Cooling Time**	Minutes	5	5	5	5	5	5

* If the motor becomes uncomfortably hot to the touch, stop winching immediately and let it cool down for 5 minutes. Do not pull for more than one minute at or near the rated load.

** Electric winches are designed and made for intermittent use and should not be used in constant duty applications.

Line Pull and Cable Capacity Per Layer						
Line of Cable		1	2	3	4	5
Rated Line Pull	lb.	3500	2858	2415	2092	1844
	kg.	1588	1296	1095	949	836
Cable Capacity	ft	7.2	15.4	24.7	34.5	50
	m	2.2	4.7	7.5	10.5	15.2

Use double line and snatch block for pulling loads over 50%.

SPECIFICATIONS

Parts Diagram

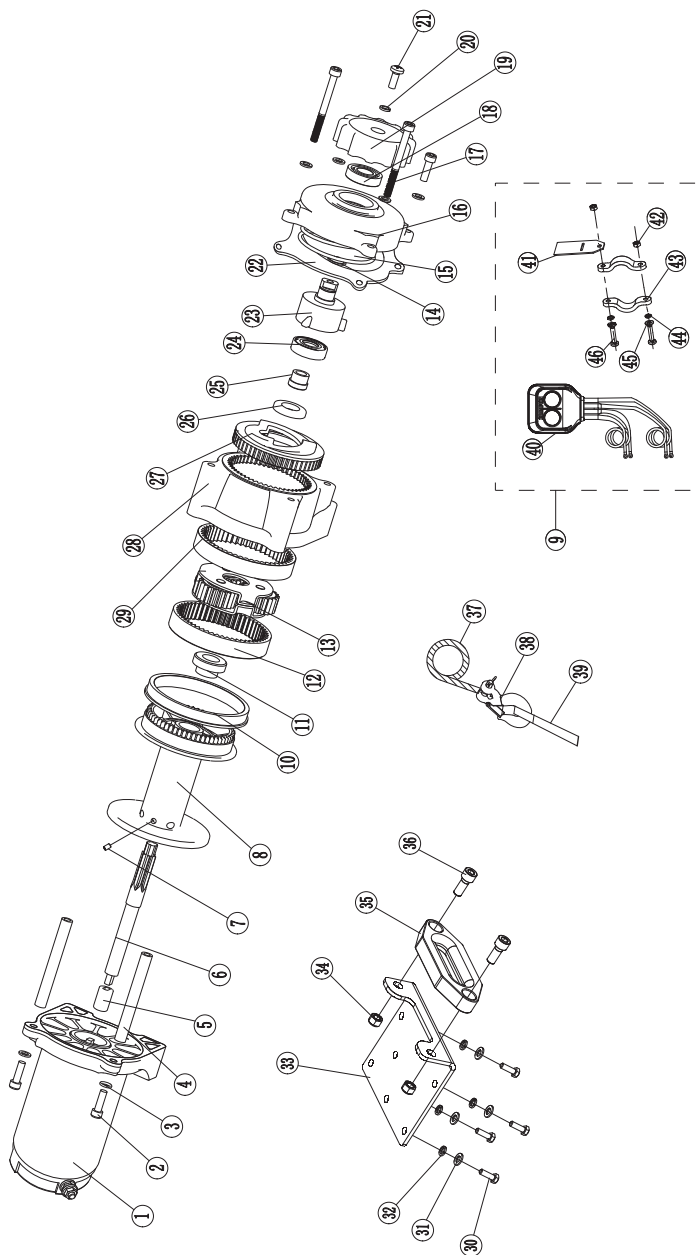

#	Part Number	Description	Qty
1	350100A-BF	Motor Assembly - Black Flat	1
2	250001-D	Hexagon Socket Head Screw M6 x 20 - Dacromet	4
3	250002-D	Flat Washer Ø6 - Dacromet	6
4	250003	Tie Bar	2
5	250004	Bushing Shaft	1
6	340001	Coupling Shaft	1
7	250083	Hexagon Socket Head Screw M5 x 8	1
8	350200A-BF	Steel Drum - Flat Black	1
9	451500	Switch Assembly	1
10	250008	Rear Bush Drum	1
11	250009	Front Thrust Washer	1
12	340002	Gear Ring Output	1
13	340003	Gear Carrier Assembly	1
14	250011	Retaining Ring Clip	1
15	250012	Spring	1
16	250013-BF	Cover Clutch Housing - Black Flat	1
17	250014-D	Hexagon Socket Head Screw M6 x 70 - Dacromet	2
18	GB2760BB16002-SS	Radial Ball Bearing 16002 Sealed	1
19	250016-BF	Clutch Cap - Black Flat	1
20	250017-D	Lock Washer Ø6 - Dacromet	1
21	250018-D	Cross Recessed Pan Head Screw M6 x 16 - Dacromet	1
22	250072	Gasket	1
23	250019	Axis Support Bushing	1
24	GB2760BB06002-SS	Radial Ball Bearing 6002 Sealed	1
25	250021	Clutch Bushing	1
26	250022	Above Clutch Axes Washer	1
27	250023	Cam Clutch Gear	1

#	Part Number	Description	Qty
28	250024-BF	Gear Housing/End Bearing - Black Flat	1
29	340004	Gear Ring	1
30	450021-D	Hexagon Head Bolt M8 x 25 - Dacromet	4
31	300020-D	Lock Washer Ø8 - Dacromet	4
32	300019-D	Flat Washer Ø8 - Dacromet	4
33	250086-BF	Mounting Channel - Black Flat	1
34	250036-D	Lock Nut M10 - Dacromet	2
35	100374	Aluminum Hawse - 124mm, CHAMPION Logo	1
36	250087-D	Hexagon Socket Head Screw M10 x 25 - Dacromet	2
37	350300	Synthetic Rope: 3/16 In.(D) x 50 Ft(L), Grey(Smoke)	1
38	C20002	1/4 in. Clevis Hook - White Zinc	1
39	410022	Yellow Strap	1
40	450500A	Control Switch - Black	1
41	300037-BF	Control Switch Mounting Plate - Black Flat	1
42	400025-D	Nut M5 - Dacromet	2
43	400026-BF	Handlebar Switch Clamp - Black Flat	2
44	400024-D	Lock Washer Ø5 - Dacromet	2
45	400023-D	Flat Washer Ø5 - Dacromet	2
46	400022-D	Hexagon Socket Head /Screw M5 x 25 - Dacromet	2

WARRANTY

CHAMPION POWER EQUIPMENT
2 YEAR LIMITED WARRANTY

Warranty Qualifications

To register your product for warranty and FREE lifetime call center technical support please visit:

<https://www.championpowerequipment.com/register>

To complete registration you will need to include a copy of the purchase receipt as proof of original purchase. Proof of purchase is required for warranty service. Please register within ten (10) days from date of purchase.

Repair/Replacement Warranty

CPE warrants to the original purchaser that the mechanical and electrical components will be free of defects in material and workmanship for a period of two years (parts and labor) from the original date of purchase and 180 days (parts and labor) for commercial and industrial use. Transportation charges on product submitted for repair or replacement under this warranty are the sole responsibility of the purchaser. This warranty only applies to the original purchaser and is not transferable.

Do Not Return The Unit To The Place Of Purchase

Contact CPE's Technical Service and CPE will troubleshoot any issue via phone or e-mail. If the problem is not corrected by this method, CPE will, at its option, authorize evaluation, repair or replacement of the defective part or component at a CPE Service Center. CPE will provide you with a case number for warranty service. Please keep it for future reference. Repairs or replacements without prior authorization, or at an unauthorized repair facility, will not be covered by this warranty.

Warranty Exclusions

This warranty does not cover the following repairs and equipment:

Normal Wear

Products with mechanical and electrical components need periodic parts and service to perform well. This warranty does not cover repair when normal use has exhausted the life of a part or the equipment as a whole.

Installation, Use and Maintenance

This warranty will not apply to parts and/or labor if the product is deemed to have been misused, neglected, involved in an accident, abused, loaded beyond the product's limits, modified, installed improperly or connected incorrectly to any electrical component. Normal maintenance is not covered by this warranty and is not required to be performed at a facility or by a person authorized by CPE.

Other Exclusions

This warranty excludes:

- Cosmetic defects such as paint, decals, etc.
- Wear items such as winch cable, etc.
- Accessory parts such as storage covers.
- Failures due to acts of God and other force majeure events beyond the manufacturer's control.
- Problems caused by parts that are not original Champion Power Equipment parts.

Limits of Implied Warranty and Consequential Damage

Champion Power Equipment disclaims any obligation to cover any loss of time, use of this product, freight, or any incidental or consequential claim by anyone from using this product. THIS WARRANTY IS IN LIEU OF ALL OTHER WARRANTIES, EXPRESS OR IMPLIED, INCLUDING WARRANTIES OF MERCHANTABILITY OR FITNESS FOR A PARTICULAR PURPOSE.

A unit provided as an exchange will be subject to the warranty of the original unit. The length of the warranty governing the exchanged unit will remain calculated by reference to the purchase date of the original unit. This warranty gives you certain legal rights which may change from state to state or province to province. Your state or province may also have other rights you may be entitled to that are not listed within this warranty.

Contact Information

Address

Champion Power Equipment, Inc.
Customer Service
12039 Smith Ave.
Santa Fe Springs, CA 90670 USA
www.championpowerequipment.com

Customer Service

Mon – Fri 8:30 AM – 5:00 PM (PST/PDT)
Toll Free: 1-877-338-0999
info@championpowerequipment.com
Fax no.: 1-562-236-9429

Technical Service

Mon – Fri 8:30 AM – 5:00 PM (PST/PDT)
Toll Free: 1-877-338-0999
tech@championpowerequipment.com
24/7 Tech Support: 1-562-204-1188