



OPERATOR'S MANUAL

MODEL #100587
4400 PSI PRESSURE WASHER



  **1-877-338-0999**

or visit championpowerequipment.com

SAVE THESE INSTRUCTIONS. This manual contains important safety precautions which should be read and understood before operating the product. Failure to do so could result in serious injury. This manual should remain with the product.

Specifications, descriptions and illustrations in this manual are as accurate as known at the time of publication, but are subject to change without notice.

TABLE OF CONTENTS

Introduction	3	Storage	23
Safety Definitions	3	Pressure Washer Storage	23
Important Safety Instructions	4	Engine Stored for Less than 30 Days	23
Safety Labels	7	Engine Stored for Over 30 Days	23
Safety Symbols	8	Winter Storage	23
Operation Symbols	9	Specifications	25
Quickstart Label Symbols	10	Pressure Washer Specifications	25
Controls and Features	11	Engine Specifications	25
Parts Included	12	Oil Specifications	25
Assembly	12	Fuel Specifications	25
Remove the Pressure Washer from the Shipping Carton	12	Spark Plug Specifications	25
Install Handle, Support Leg and Wheels	12	Valve Specifications	25
Add Engine Oil	14	Important Message About Temperature	25
Add Fuel	15	Parts Diagram	26
Attach the Trigger Gun Assembly	15	Parts List	27
Connect the High-Pressure Hose	16	Engine Parts Diagram	28
Connect the Garden Hose	16	Engine Parts List	29
Install the Vented Oil Cap	16	Troubleshooting	31
Operation	17		
Pressure Washer Location	17		
Before Starting the Engine	17		
Starting the Engine	17		
Distance from Cleaning Surface	17		
High-Pressure Wash	18		
Low-Pressure Wash	19		
System Flush	19		
Depressurize System	19		
Operating Tips	19		
Stopping the Engine	20		
Operation at High Altitude	20		
Maintenance	20		
Cleaning the Pressure Washer	21		
Pump Oil	21		
Changing the Engine Oil	21		
Cleaning and Adjusting the Spark Plug(s)	21		
Cleaning the Air Filter	22		
Cleaning the Spark Arrester	22		
Adjusting the Governor	22		
Maintenance Schedule	22		

INTRODUCTION

Congratulations on your purchase of a Champion Power Equipment (CPE) product. CPE designs, builds, and supports all of our products to strict specifications and guidelines. With proper product knowledge, safe use, and regular maintenance, this product should bring years of satisfying service.

Every effort has been made to ensure the accuracy and completeness of the information in this manual, and we reserve the right to change, alter and/or improve the product and this document at any time without prior notice.

Since CPE highly values how our products are designed, manufactured, operated and are serviced, and also highly value your safety and the safety of others, we would like you to take the time to review this product manual and other product materials thoroughly and be fully aware and knowledgeable of the assembly, operation, dangers and maintenance of the product before use. Fully familiarize yourself, and make sure others who plan on operating the product fully familiarize themselves too, with the proper safety and operation procedures before each use. Please always exercise common sense and always err on the side of caution when operating the product to ensure no accidents, property damage, or injury occurs. We want you to continue to use and be satisfied with your CPE product for years to come.

When contacting CPE about parts and/or service, you will need to supply the complete model and serial numbers of your product. Transcribe the information found on your product's nameplate label to the table below.

CHAMPION POWER EQUIPMENT SUPPORT
1-877-338-0999
MODEL NUMBER
100587
SERIAL NUMBER
DATE OF PURCHASE
PURCHASE LOCATION

SAFETY DEFINITIONS

The purpose of safety symbols is to attract your attention to possible dangers. The safety symbols, and their explanations, deserve your careful attention and understanding. The safety warnings do not by themselves eliminate any danger. The instructions or warnings they give are not substitutes for proper accident prevention measures.

DANGER

DANGER indicates a hazardous situation which, if not avoided, will result in death or serious injury.

WARNING

WARNING indicates a hazardous situation which, if not avoided, could result in death or serious injury.

CAUTION

CAUTION indicates a hazardous situation which, if not avoided, could result in minor or moderate injury.

NOTICE

NOTICE indicates information considered important, but not hazard-related (e.g., messages relating to property damage).

IMPORTANT SAFETY INSTRUCTIONS

⚠ WARNING

Cancer and Reproductive Harm – www.P65Warnings.ca.gov

⚠ DANGER

Engine exhaust contains carbon monoxide, a colourless, odourless, poisonous gas. Breathing carbon monoxide will cause nausea, dizziness, fainting or death. If you start to feel dizzy or weak, get to fresh air immediately.

OPERATE PRODUCT OUTDOORS ONLY IN A WELL VENTILATED AREA AND POINT EXHAUST AWAY.

DO NOT operate the product inside any building, including garages, basements, crawlspaces and sheds, enclosure or compartment, including the compartment of a recreational vehicle.

DO NOT allow exhaust fumes to enter a confined area through windows, doors, vents or other openings.

⚠ DANGER

Rotating parts can entangle hands, feet, hair, clothing and/or accessories.

Traumatic amputation or severe laceration can result.

Keep hands and feet away from rotating parts.

Tie up long hair and remove jewelry.

Operate equipment with guards in place.

DO NOT wear loose-fitting clothing, dangling drawstrings or items that could become caught.

⚠ WARNING

Sparks can result in fire or electrical shock.

When servicing the pressure washer:

Disconnect the spark plug wire and place it where it cannot contact the plug.

DO NOT check for spark with the plug removed.

Use only approved spark plug testers.

⚠ WARNING

Contact with electrical power source can cause electric shock or burn.

NEVER spray in the direction of or near a power source/ electrical outlet.

⚠ WARNING

Running engines produce heat. Severe burns can occur on contact. Combustible material can catch fire on contact.

DO NOT touch hot surfaces.

Avoid contact with hot exhaust gases.

Allow equipment to cool before touching.

Maintain at least 3 ft. (91.4 cm) of clearance on all sides to ensure adequate cooling.

Maintain at least 5 ft. (1.5 m) of clearance from combustible materials.

🗨 NOTICE

DO NOT let water in the pump freeze.

See Storage section in the manual for instructions regarding winter storage.

If water has frozen in the pressure washer, thaw the pressure washer in a warm room before starting.

DO NOT pour hot water on or into the pump; internal parts will be damaged and your warranty will be voided.

🗨 NOTICE

NEVER run the unit dry.

Be sure the water supply is completely turned on before operating the unit.

⚠ WARNING

NEVER spray flammable liquids or use pressure washer in areas containing combustible dust, liquids, or vapour.

NEVER operate this machine in a closed building or in or near an explosive environment.

- DO NOT remove fuel tank cap or fill fuel tank while engine is hot or running (allow engine to cool two minutes before refueling). Always fill the tank slowly.
- NEVER disconnect the high pressure discharge hose from the machine while the system is pressurized.

⚠ WARNING

Rapid retraction of the starter cord will pull hand and arm towards the engine faster than you can let go.

Unintentional startup can result in entanglement, traumatic amputation or laceration.

Broken bones, fractures, bruises or sprains could result.

When starting engine, pull the starter cord slowly until resistance is felt and then pull rapidly to avoid kickback.

⚠ DANGER

Keep clear of nozzle.

DO NOT point the spray wand at a person, an animal or yourself.

Always wear safety glasses or goggles and protective equipment (hearing protection, gloves, rubber boots, protective clothing) when operating or performing maintenance.

- NEVER put hand or fingers over the spray tip while operating the unit.
- NEVER try to stop or deflect leaks with any body part.
- ALWAYS engage the trigger safety latch in the safe position when spraying is stopped even if only for a few moments.

⚠ WARNING

Always wear eye protection with side shields marked to comply with ANSI Z87.1.

Following this rule will reduce the risk of serious personal injury.

🗨 NOTICE

Improper treatment or use of the pressure washer can damage it, shorten its life and void your warranty.

Use the pressure washer only for intended uses.

Operate only on level surfaces.

DO NOT expose pressure washer to excessive moisture, dust, or dirt.

DO NOT allow any material to block the cooling slots.

DO NOT use the pressure washer if:

- Equipment sparks, smokes or emits flames
- Equipment vibrates excessively

⚠ DANGER

Risk of injection or injury. High pressure jets can be dangerous if subject to misuse.

- DO NOT direct discharge stream at persons, animals, electrical devices, or the machine itself.
- ALWAYS point spray gun in safe direction. Every time you stop the engine, squeeze trigger of spray gun to relieve any trapped pressure.

🗨 NOTICE

ONLY use cold water.

🗨 NOTICE

Water under high pressure can damage fragile surfaces.

- ALWAYS: practice on a inconspicuous test area to understand when damage may occur.
- DO NOT: Point spray gun at glass.
- NEVER: Point the spray nozzle at persons, animals, electrical devices, plants or the machine itself.

⚠ WARNING

Use of pressure washers can create wet walking surfaces. While using a pressure washer, forces from the gun can cause you to loose footing and fall.

- Use only on a level surface.
- Make sure there is proper drainage to dissipate water.
- DO NOT: use on elevated surface where kickback could result in a serious fall.
- ALWAYS grasp the gun with two hands to prevent potential injury due to high pressure from gun.

⚠ WARNING

High pressure spray can splash back at operator or propel objects.

NEVER: allow children to operate any pressure washer or play nearby.

NEVER: leave spray gun unattended while machine is running or until after engine has been turned off and pressure has been relieved from the spray gun.

NEVER: repair high pressure hose, replace it.

NEVER: repair leaking connections with sealant, replace damaged O-rings.

NEVER: use spray gun with a damaged or altered trigger lock.

NEVER: secure the trigger in the open/spray position.

ALWAYS: keep high pressure hose connected to spray gun and pump while in use.

ALWAYS: be certain that spray gun nozzles and accessories are properly attached to the lance.

ALWAYS: wear safety goggles when operating this equipment. NOTE: Safety goggles cover the sides, top and bottom of the eyes. Don't confuse safety glasses for goggles.

⚠ DANGER

Fuel and fuel vapours are highly flammable and extremely explosive.

Fire or explosion can cause severe burns or death.

Unintentional startup can result in entanglement, traumatic amputation or laceration.

When adding or removing fuel:

Turn the pressure washer off and let it cool for at least two minutes before removing the fuel cap.

Loosen the cap slowly to relieve pressure in the tank.

Only fill or drain fuel outdoors in a well-ventilated area.

DO NOT pump gas directly into the pressure washer at the gas station. Use an approved container to transfer the fuel to the pressure washer.

DO NOT overfill the fuel tank.

Always keep fuel away from sparks, open flames, pilot lights, heat and other sources of ignition.

DO NOT light or smoke cigarettes.

When starting the pressure washer:

DO NOT attempt to start a damaged pressure washer.

Make certain that the gas cap, air filter, spark plug, fuel lines and exhaust system are properly in place.

Allow spilled fuel to evaporate fully before attempting to start the engine.

Make certain that the pressure washer is resting firmly on level ground.

When operating the pressure washer:

DO NOT move or tip the pressure washer during operation.

DO NOT tip the pressure washer or allow fuel or oil to spill.

When transporting or servicing the pressure washer:

Make certain that the fuel shutoff valve is in the off position and the fuel tank is empty.

Disconnect the spark plug wire.

When storing the pressure washer:





Store away from sparks, open flames, pilot lights, heat and other sources of ignition.

Safety Labels

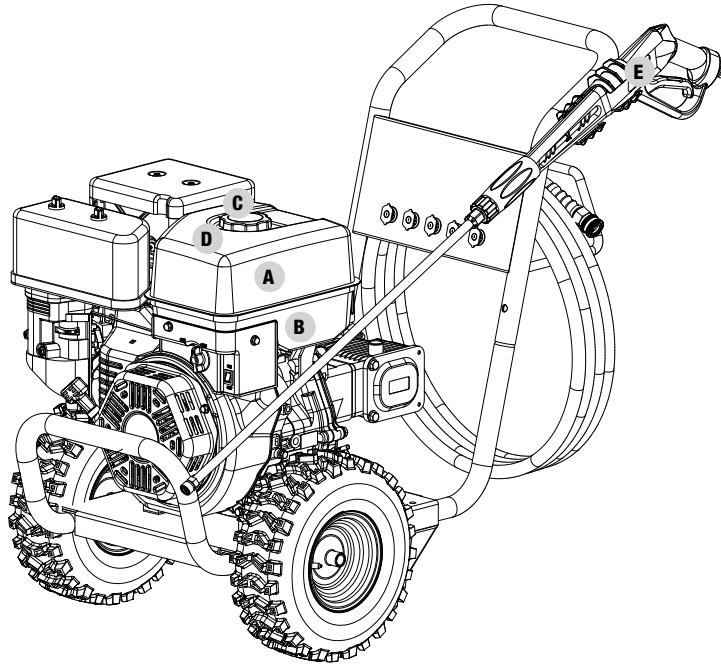
These labels warn you of potential hazards that can cause serious injury. Read them carefully.

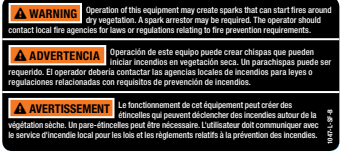

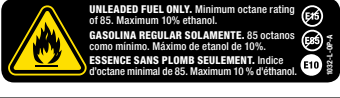



If a label comes off or becomes hard to read, contact Technical Support Team for possible replacement.



	LABEL	DESCRIPTION
A		Safety Icons/ CO Danger
B		Spark Arrestor
C		Hot Surface
D		Fuel
E		Trigger Gun



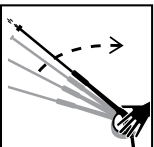

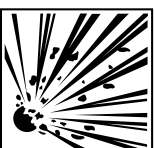

Safety Symbols





Some of the following symbols may be used on this product. Please study them and learn their meaning. Proper interpretation of these symbols will allow you to more safely operate the product.

SYMBOL	MEANING
	<p>Read the Operator's Manual. To reduce the risk of injury, user must read and understand operator's manual before using this product.</p>
	<p>Electric Shock. Failure to use in dry conditions and to observe safe practices can result in electric shock.</p>
	<p>Toxic Fumes. The engine exhaust from this product contains chemicals known to the state of California to cause cancer and birth defects and other reproductive harm.</p> <p>Risk of Asphyxiation. This engine emits carbon monoxide, an odourless, colourless poison gas. Breathing carbon monoxide can cause nausea, fainting or death. Use only in a well ventilated area.</p>
	<p>Risk of Injections. To reduce the risk of injection or injury, never direct a water stream towards people or pets or place any body part in the stream. Leaking hoses and fittings are also capable of causing injection injury. Do not hold hoses or fittings.</p>
	<p>Eye and Ear Protection. Always wear safety goggles or safety glasses with side shields, and as necessary a full face shield as well as full ear protection when operating this product.</p>
	<p>Kickback. To reduce the risk of injury from kickback, hold the trigger gun securely with both hands when the machine is on.</p>
	<p>Risk of Fire. Fuel and its vapours are extremely flammable and explosive. Fire can cause severe burns or death. Do not add fuel while the product is operating or still hot. Do not spray flammable liquids. Operate only where open flame is permitted.</p>
	<p>Risk of Explosion. Do not spray flammable liquids. Flammable liquids, fuel, and their vapours are explosive and can cause severe burns or death.</p>

Operation Symbols

Some of the following symbols may be used on this product. Please study them and learn their meaning. Proper interpretation of these symbols will allow you to more safely operate the product.

SYMBOL	MEANING
	0° Nozzle
	15° Nozzle
	25° Nozzle
	40° Nozzle
	Detergent Nozzle
	Choke

SYMBOL	MEANING
	Run
	Fuel Valve
	Throttle: Full Speed
	Throttle: Low Speed

Quickstart Label Symbols

Some of the following symbols may be used on this product. Please study them and learn their meaning. Proper interpretation of these symbols will allow you to more safely operate the product.

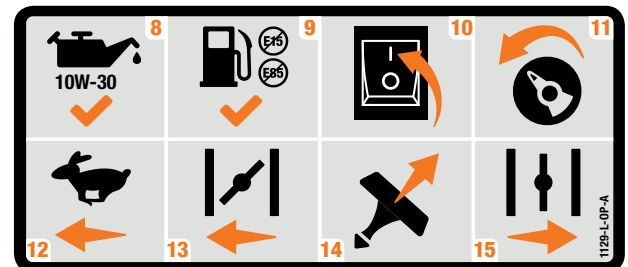

Assembly

1. Attach the spray wand to the trigger gun.
2. Connect high pressure hose to gun.
3. Connect high pressure hose to pump.
4. Connect garden hose to machine.
5. Attach nozzle.
6. Turn water supply on.
7. Pull trigger on trigger gun to purge all the air.

Starting the Engine

8. Check oil level
9. Check fuel level.
10. Press the engine switch to “**ON**” position.
11. Rotate the fuel valve to the “**ON**” position.
12. Move the throttle lever to the “**FAST**” position.
13. Move the choke lever to the “**CHOKE**” position.
14. Pull the starter cord.
15. Move the choke lever to “**RUN**” position.

CONTROLS AND FEATURES

Read this operator's manual before operating your pressure washer. Familiarize yourself with the location and function of the controls and features. Save this manual for future reference.

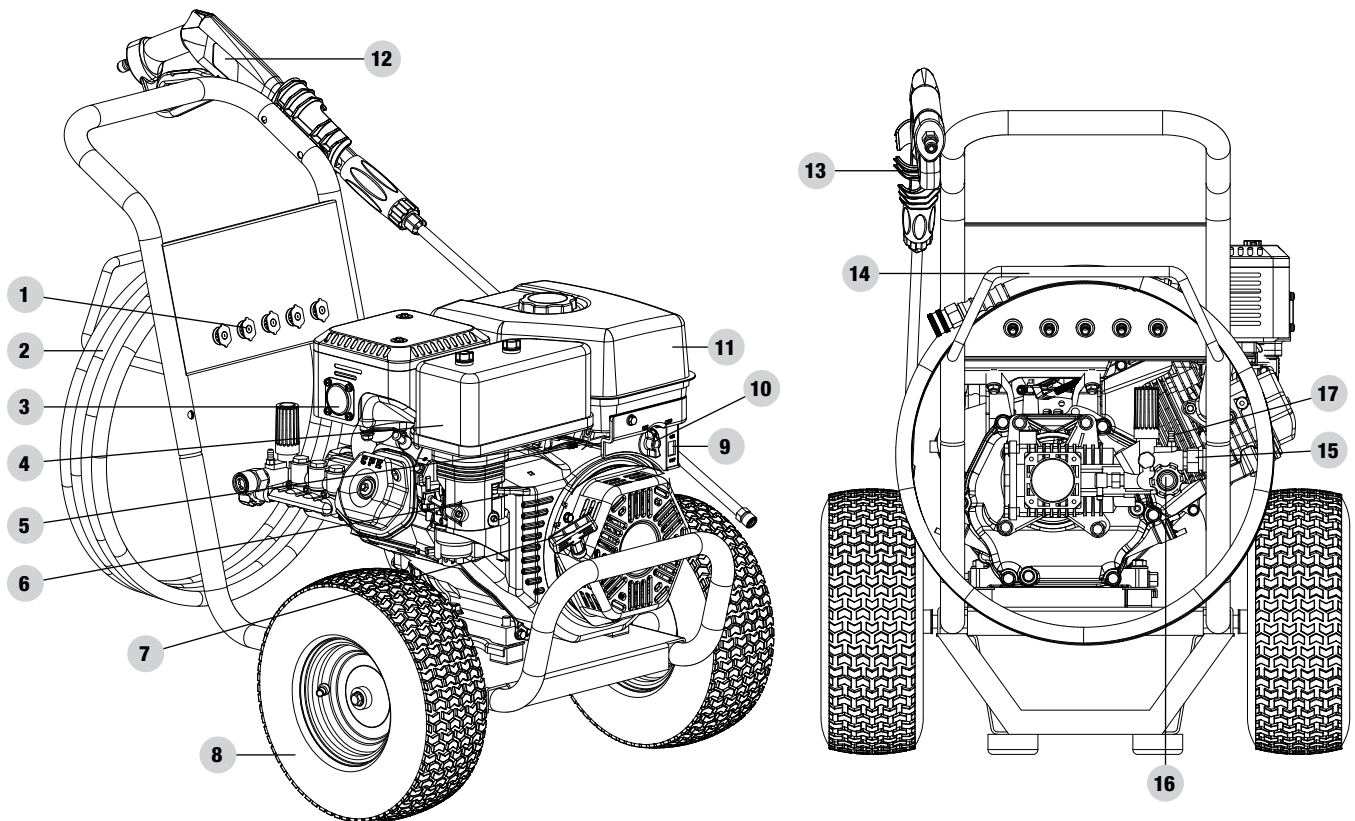

1. **Nozzles**
2. **High-Pressure Hose**
3. **Muffler**
4. **Air Filter** – Protects the engine by filtering dust and debris from the intake air
5. **Throttle Lever** – Used to control the engine speed
6. **Choke Lever** – Used to start the engine when cold
7. **Recoil Starter** – Used to manually start the engine
8. **13 in. (33 cm) Pneumatic Wheels**
9. **Engine Switch**
10. **Fuel Valve Knob** – Used to turn fuel supply on and off to engine
11. **Fuel Tank** – 1.6 gal. (6.2 L)
12. **Trigger Gun Assembly** – Gun and spray wand
13. **Trigger Gun Holder** – Used to hold gun when assembled and not in use
14. **High-Pressure Hose Hanger** – Used to hold high pressure hose when not in use
15. **High-Pressure Hose Outlet**
16. **Garden Hose Inlet**
17. **Detergent Hose Connection Barb**

Parts Included

Gun Assembly

Spray Wand (A).....	1
Trigger Gun (B).....	1
Quick Connect Nozzles (C).....	5

Hoses

50 ft. (15.2 m) High Pressure Hose (D).....	1
4 ft. (1.2 m) Detergent Hose (E).....	1

Other

Oil Funnel (F).....	1
---------------------	---

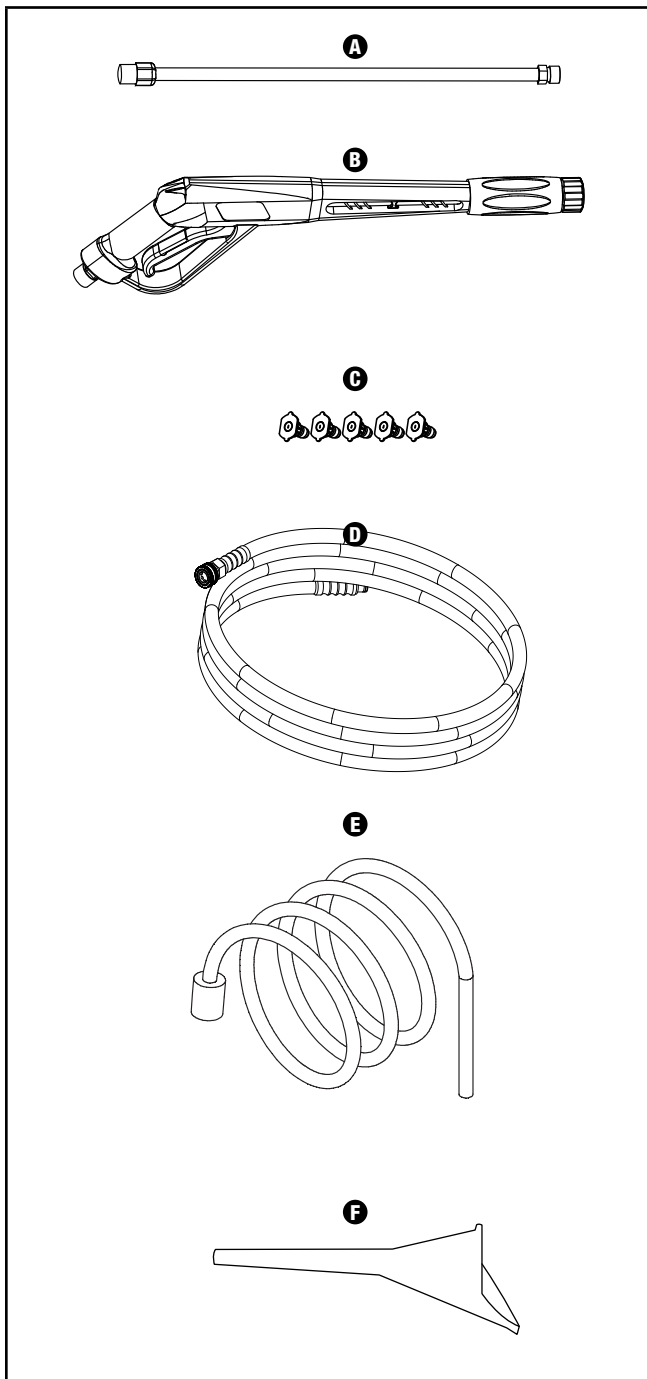

ASSEMBLY

Your pressure washer requires some assembly. This unit ships from our factory without oil. It must be properly serviced with fuel and oil before operation. If you have any questions regarding the assembly of your pressure washer, call our help line at 1-877-338-0999. Please have your serial number and model number available.

Remove the Pressure Washer from the Shipping Carton

1. Set the shipping carton on a solid, flat surface.
2. Remove everything from the carton except the pressure washer.
3. Carefully cut each corner of the box from top to bottom.

Install Handle, Support Leg and Wheels

1. Line up the handle with the bottom frame.
2. Make sure the handle holes are lined up with the bottom frame spring button (A). Front face of shroud (decal side) should face the engine.
3. Slide the handle downward on the bottom frame until the handle contacts the spring buttons. Depress the spring buttons and slide the handle downward until the buttons have popped through the holes on the handle frame. A "click" may sound. (B)
4. Gently pull up on the handle to make sure that two frames have made a solid connection and that the handle cannot be pulled off without pressing on the spring buttons to release it.

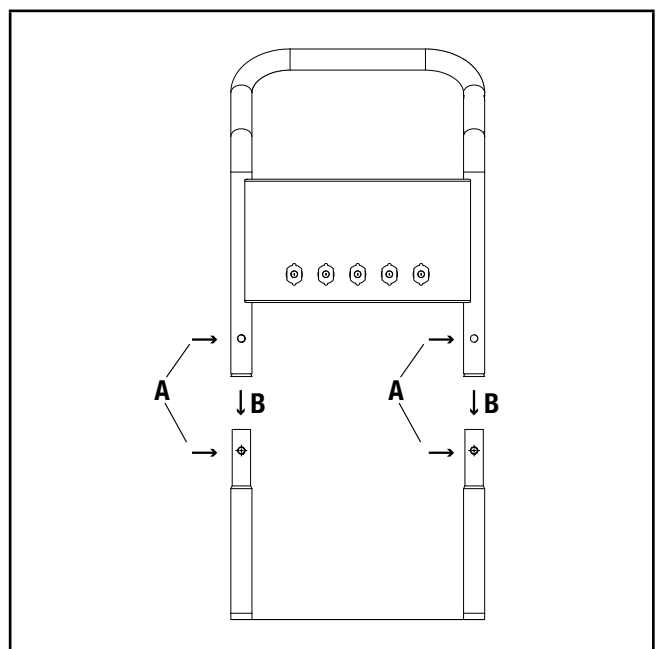

5. Before adding fuel and oil, tip the pressure washer on its side.
6. Slide the M10x165 wheel bolt through the sleeve, wheel and washer (C).
7. Slide the bolt through the hole on the side of the frame.
8. Fasten securely with the M10 nut.

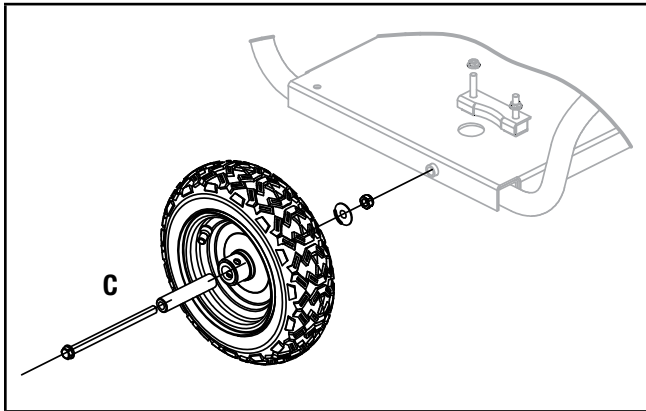

9. Repeat steps 6-8 to attach the second wheel on opposite side of the frame.
10. Attach the metal support bracket to the back and bottom of the frame using the M8 x 55mm bolt included. Rubber feet facing outward (D).

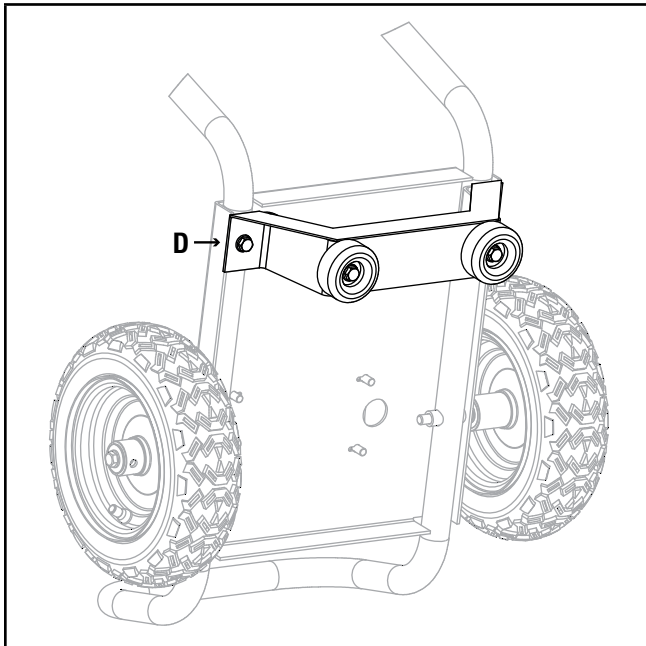

11. Fasten securely with the M8 nut.
12. Insert spray nozzles into proper position on handle shroud. (E) NOTE: Nozzle size is located on the face of the nozzle (See image below).

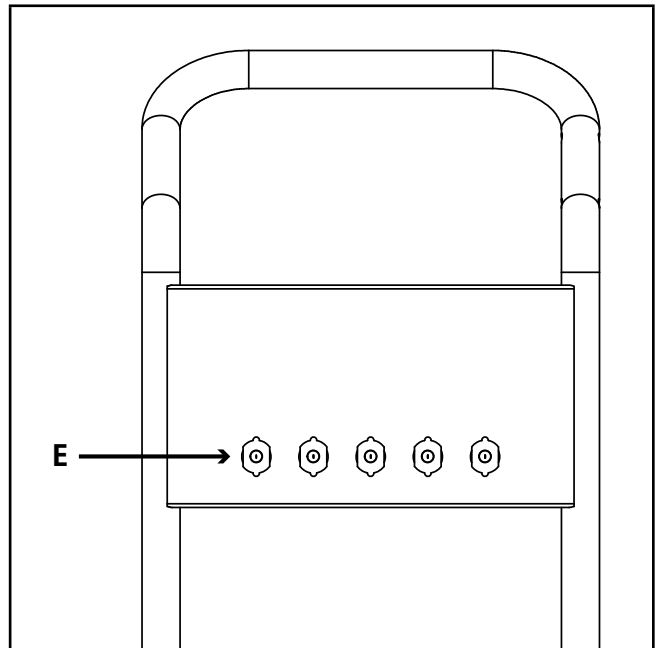

13. Attach the trigger gun holder to the handle using the M6 x 45mm bolts and M6 lock nuts included.

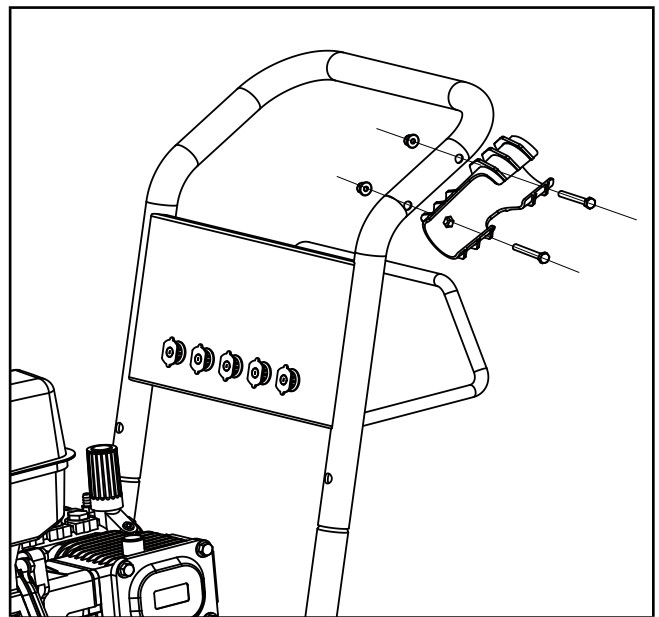

Add Engine Oil

⚠ CAUTION

DO NOT attempt to crank or start the engine before it has been properly filled with the recommended type and amount of oil. Damage to the pressure washer as a result of failure to follow these instructions will void your warranty.

🗨 NOTICE

The recommended oil type is 10W-30 automotive oil.

1. Place the pressure washer on a flat level surface.

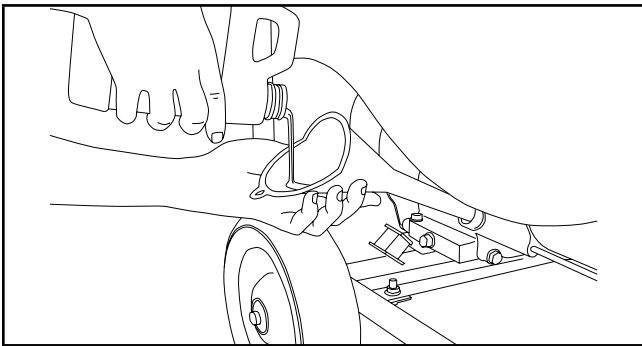

2. Remove oil fill cap/dipstick to add oil.
3. Add up to 37.2 fl. oz. (1.2 qt.) (not included) of oil and replace oil fill cap/dipstick. DO NOT OVERFILL.
4. Check engine oil level daily and add as needed.

🗨 NOTICE

Once oil has been added, a visual check should show oil about 1-2 threads from running out of the fill hole.

If using the dipstick to check oil level, DO NOT screw in the dipstick while checking.

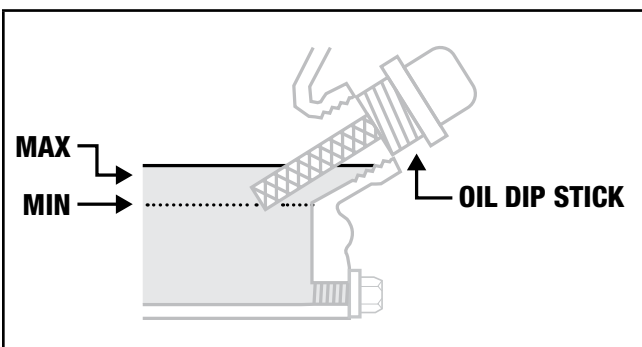

Recommended Oil Type									
		10W-30							
	5W-30					10W-40			
	5W-30 Synthetic								
°F	-20	0	20	40	60	80	100	120	
°C	-28.9	-17.8	-6.7	4.4	15.6	26.7	37.8	48.9	
Ambient temperature									

🗨 NOTICE

We consider the first 5 hours of run time to be the break-in period for the engine. During the break-in period we recommend using standard automotive non-synthetic blended oils. After the break-in period, synthetic lubricant can be used, but is not required. Adjusting throttle setting will increase/decrease engine speed helping to seat piston rings. Avoid bogging or lugging the engine down and avoid prolonged running at constant RPM. After the 5-hour break-in period, change the oil. Using synthetic lubricants does not increase the recommended oil change interval.

⚠ CAUTION

The engine is equipped with a low oil shut-off and will stop when the oil level in the crankcase falls below the threshold level.

🗨 NOTICE

Check oil often during the break-in period. Refer to the Maintenance section for recommended service intervals.

🗨 NOTICE

The engine rotor has a sealed, pre-lubricated ball bearing that requires no additional lubrication for the life of the bearing.

🗨 NOTICE

Weather will affect engine oil and engine performance. Change the type of engine oil used based on weather conditions to suit the engine needs.

Add Fuel

1. Use clean, fresh, regular unleaded fuel with a minimum octane rating of 85 and an ethanol content of less than 10% by volume.
2. DO NOT mix oil with fuel.
3. Clean the area around the fuel cap.
4. Remove the fuel cap.
5. Slowly add fuel to the tank. DO NOT OVERFILL. Fuel can expand after filling. A minimum of ¼ in. (6.4 mm) of space left in the tank is required for fuel expansion, more than ¼ in. (6.4 mm) is recommended. Fuel can be forced out of the tank as a result of expansion if it is overfilled, and can affect the stable running condition of the product. When filling the tank, it is recommended to leave enough space for the fuel to expand.

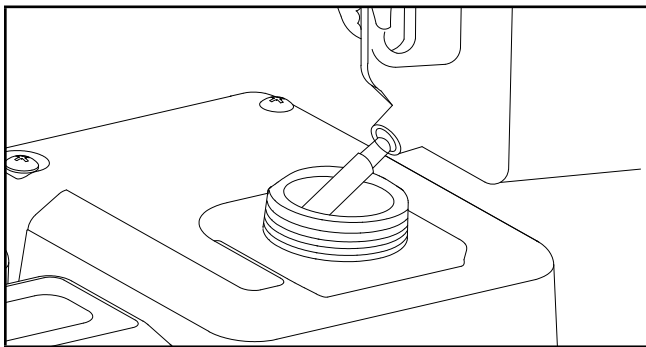

6. Screw on the fuel cap and wipe away any spilled fuel.

⚠ WARNING

Pouring fuel too fast through the fuel screen may result in blow back of fuel at the operator while filling.

⚠ CAUTION

Use regular unleaded gasoline with a minimum octane rating of 85.

Do not mix oil and gasoline.

Fill tank to approximately ¼ in. (6.4 mm) below the top of the tank to allow for fuel expansion.

DO NOT pump gas directly into the pressure washer at the gas station. Use an approved container to transfer the fuel to the pressure washer.

DO NOT fill fuel tank indoors.

DO NOT fill fuel tank when the engine is running or hot.

DO NOT overfill the fuel tank.

DO NOT light cigarettes or smoke when filling the fuel tank.

🗨 NOTICE

Our engines work well with 10% or less ethanol blend fuels. When using blended fuels there are some issues worth noting:

- Ethanol-gasoline blends can absorb more water than gasoline alone.
- These blends can eventually separate, leaving water or a watery goo in the tank, fuel valve and carburetor.
- With gravity-fed fuel supplies, this compromised fuel can be drawn into the carburetor and cause damage to the engine and/or potential hazards.
- There are only a few suppliers of fuel stabilizer that are formulated to work with ethanol blend fuels.
- Any damages or hazards caused by using improper fuel, improperly stored fuel, and/or improperly formulated stabilizers, are not covered by manufacturer's warranty.

It is advisable to always shut off the fuel supply, run the engine to fuel starvation and drain the tank when the equipment is not in use for more than 30 days.

Attach the Trigger Gun Assembly

1. Attach the spray wand (A) to the trigger gun (B).
2. Rotate (clockwise) the M22 coupler on the trigger gun until the spray wand is secure. Tighten connection. DO NOT OVER-TIGHTEN.

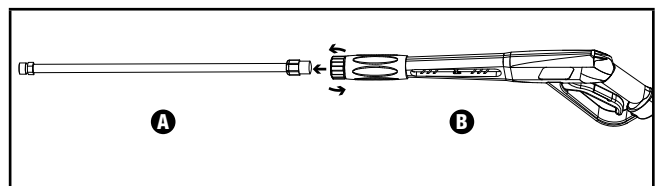

3. Connect the end of the high pressure hose (C) to the gun inlet by sliding back the metal collar on the female connector on the high pressure hose. Insert male fitting (on trigger gun) and release collar. Gently tug on hose to ensure proper connection.

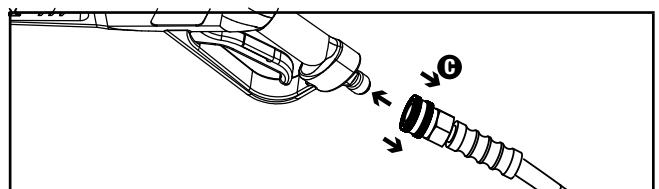

Connect the High-Pressure Hose

1. Completely uncoil and straighten the high-pressure hose to prevent kinks.
2. Align the male end of the high-pressure hose to the quick change connector on the high-pressure pump.
3. Insert the high-pressure hose connection into the pump quick change fitting by sliding back the metal collar on the female connector on the high-pressure pump and fully insert male fitting (on high-pressure hose) and release collar.
4. Gently tug on hose to ensure proper connection.

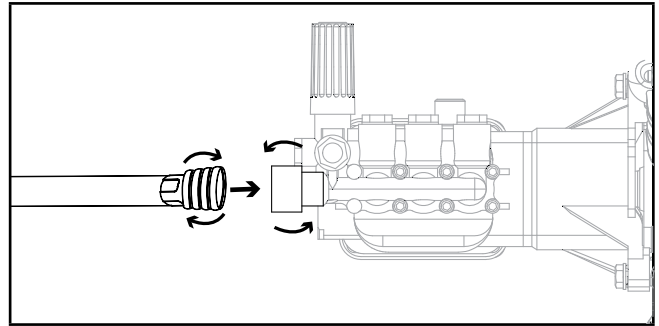
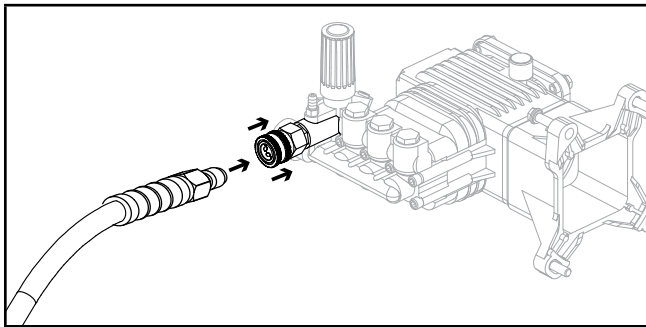

NOTICE

Do not run the pressure washer without water supply connected and turned on, as this may damage the high pressure seals and decrease pump life. Completely unwind the hose from its reel or coil and make sure the hose is not being restricted by tires, rocks, or any other objects that may lessen or prevent water flow to the pressure washer.

Connect the Garden Hose

The water supply must come from a pressurized water spicket. NEVER use hot water or water from pools, lakes, etc. Before connecting the garden hose to the pressure washer:

1. Run water through the hose for 30 seconds to clean any debris from the hose.
2. Inspect the screen and gasket in the water intake.
3. If the screen and gasket is damaged, do not use the machine until the screen has been replaced.
4. If the screen is dirty, clean it before connecting the garden hose to the machine.

To connect the garden hose to the machine:

1. Completely uncoil the garden hose or remove completely from reel to prevent kinks.

NOTICE

There must be a minimum of 10 ft. (3 m) of unrestricted hose between the pressure washer intake and the hose faucet or shut off valve (such as a "Y" shut off connector).

2. With the hose faucet turned completely off, attach the end of the garden hose to the water inlet. Tighten by hand.

Install the Vented Oil Cap

Before using the pressure washer:

1. Unscrew the red shipping plug. A 17 mm or 11/16" wrench (not included) may be used. (A)
2. Remove the vented oil plug from the plastic bag.
3. Screw the vented oil plug into the pump by hand. Do not overtighten.

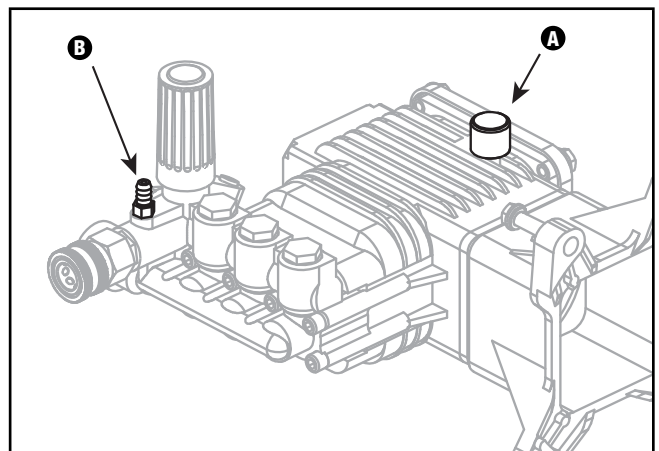

To connect the detergent hose to the pump

1. Completely uncoil the detergent hose.
2. Connect one end to detergent hose connection barb (B) on the pump.

OPERATION

Pressure Washer Location

This pressure washer must have at least 5 ft. (1.5 m) of clearance from combustible material. Leave at least 3 ft. (91.4 cm) of clearance on all sides of the pressure washer to allow for adequate cooling, maintenance and servicing. Place the pressure washer in a well ventilated area. DO NOT place the pressure washer near vents or intakes where exhaust fumes could be drawn into occupied or confined spaces. Carefully consider wind and air currents when positioning pressure washer.

Before Starting the Engine

1. Turn the water supply ON.
2. Pull the trigger on the trigger gun to purge all air from the pump and hose. This may take several minutes.
3. Do not start the engine until a steady stream of water is flowing from the nozzle.

CAUTION

Never operate your pressure washer without water.

Starting the Engine

1. Make certain the pressure washer is on a flat, level surface.
2. Turn engine switch to "ON" position (A).
3. Rotate the fuel valve to the "ON" position (B).
4. Move the throttle lever (C) to the "FAST" position.
5. Move the choke lever (D) to the "CHOKE" position.
6. Pull the starter cord slowly until resistance is felt and then pull rapidly. SEE NOTE.
7. As engine warms up, move the choke lever (D) to "RUN" and adjust the throttle (C) as needed.

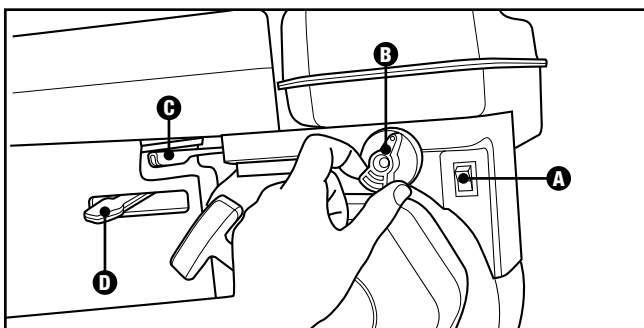

NOTICE

Keep choke lever in "CHOKE" position for 2 pulls of the recoil starter. After second pull, move choke lever to the "RUN" position for up to the next 3 pulls of the recoil starter. Too much choke leads to spark plug fouling/engine flooding due to the lack of incoming air. This will cause the engine not to start.

NOTICE

If the engine does not start after 2 pulls, relieve pump pressure by pulling the trigger on the trigger gun.

NOTICE

If the engine starts but does not run make certain that the pressure washer is on a flat, level surface. The engine is equipped with a low oil sensor that will prevent the engine from running when the oil level falls below a critical threshold.

Distance from Cleaning Surface





The distance between the spray nozzle and the cleaning surface is another factor that affects the impact force of the water. The impact force of the water increases as the nozzle is moved closer to the surface. You can vary the impact force by controlling

- The nozzle's fan pattern.
- The nozzle's angle to the cleaning surface.
- The nozzle's distance from the cleaning surface.

Never use a narrow high impact stream on a surface that is susceptible to damage. Avoid spraying windows with a narrow high impact stream or turbo nozzle. Doing so may break the glass.

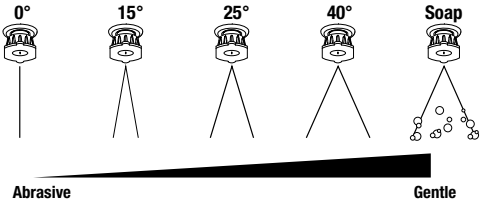
1. Before triggering the gun, select a nozzle with a wide fan pattern.
2. Place the nozzle approximately 4-5 ft. (1.2 m - 1.5 m) away from the cleaning surface. Then hold the nozzle at a 45 degree angle to the cleaning surface. Trigger the gun.
3. Vary the fan pattern spray angle and the distance to the cleaning surface until optimum cleaning efficiency is achieved without damaging the surface.

Use the following table to determine which nozzle to use.

NOZZLE SELECTION GUIDE						
		HIGH PRESSURE WASH				LOW PRESSURE WASH
		0°	15°	25°	40°	Soap
Concrete, Brick, Masonry		!	✓	✓	✓	✓
Siding, Gutters, Home			!	!	✓	✓
Fencing, Deck, Patio			!	!	✓	✓
Lawn and Garden Equipment, Boats, RVs			!	!	✓	✓
✓ Recommended nozzle ! Use with caution						

High-Pressure Wash

⚠ CAUTION

Always engage the trigger safety latch when the unit is not in use.

The trigger safety latch prevents the gun from being triggered accidentally. Push the latch fully down to engage it.

⚠ WARNING

Injection hazard.

Fully unwrap and straighten high-pressure hose prior to and during each use and do not allow it to become kinked. The high-pressure hose features an outer covering that provides strength to the hose. If the outer covering becomes damaged, stop using the hose and replace it immediately. A kinked or damaged hose can develop a high pressure leak and result in a possible injection or other serious personal injury.

🗨 NOTICE

If the starter grip and rope becomes difficult to pull, squeeze the trigger to relieve water pressure before attempting to start the engine again.

For high pressure cleaning, refer to the Nozzle Selection Guide for more information about which quick connect nozzle to choose.

⚠ CAUTION

The narrow high impact spray can damage some surfaces.

A wide fan pattern distributes the impact of the water over a larger area resulting in excellent cleaning action with reduced risk of surface damage. Clean large surface areas quickly using a wide fan pattern.

Low-Pressure Wash

Detergent Use

The use of detergents can dramatically reduce cleaning time and assist in the removal of difficult stains. Many detergents are customized for pressure washer use on specific cleaning tasks. Pressure washer detergents are as thick as water. Using thicker detergents – like dish soap – will clog the chemical injection system.

NOTICE

Use only detergents designed for pressure washers.

Do not use household detergents, acids, alkalines, bleaches, solvents, flammable material, or industrial grade solutions, which can damage the pump or cause property damage. Many detergents may require mixing prior to use. Prepare cleaning solution as instructed on the solution bottle. Always test in an inconspicuous area before beginning.

You can effectively clean surfaces by combining the chemical action of detergents with high pressure rinses. On vertical surfaces, apply the detergent starting at the bottom and work your way upward. This method prevents the detergent from sliding down and causing streaks. Begin high-pressure rinsing at the bottom and work your way upward. On particularly tough stains, use a brush in combination with detergents and high-pressure rinsing.

1. Insert the detergent suction hose (end with filter) into the detergent bottle or container.
2. Install the quick connect detergent nozzle (black) in the spray wand. Detergent will only be drawn through the pump when the black detergent nozzle is attached to the end of the wand.
3. Be sure water supply is on. Start the engine. Pull the trigger gun to spray the detergent solution.

WARNING

NEVER use bleach. It will damage the pump and void the warranty.

NOTICE

The trigger gun will only draw detergent when the black quick connect nozzle is installed in the wand.

NOTICE

When spraying detergent, the detergent will be diluted 1:12. Approximately 21 oz. (0.6 L) of detergent will be consumed for every minute sprayed.

System Flush

After using detergents, flush the suction system by placing the detergent suction tube into a bucket of clean water.

WARNING

NEVER turn the water supply off before turning the engine off.

Depressurize System

To depressurize, turn engine off, turn water supply off and squeeze gun trigger for at least 15 seconds after engine is turned off.

WARNING

NEVER disconnect the high pressure discharge hose from the machine while the system is pressurized.

To reduce the risk of bodily injury or property damage, always follow this procedure whenever spraying is stopped, when work is completed, and before checking or repairing any part of the system.

1. Engage the trigger gun lock out.
2. Turn the unit off.
3. Shut off the water supply.
4. Disengage the trigger safety latch and trigger the gun to relieve pressure.
5. Re-engage the trigger safety latch.
6. Before overnight storage, long term storage, or transporting unit, disconnect the water supply and turn off the fuel supply valve.

Operating Tips

CAUTION

Never operate your pressure washer without water.

CAUTION

Never connect your pressure washer to a hot water supply.

Connecting your pressure washer to a hot water source will significantly reduce the life of the pump and will void the warranty.

⚠ CAUTION

Running the unit for more than one minute without spraying water causes heat to build up in the pump.

In the event that the pump gets too hot, a thermal relief valve will open to release the hot water. Running the unit without spraying water can damage pump components and will void the warranty.

Stopping the Engine

1. Turn the fuel valve to the “OFF” position.
2. Let the engine run until fuel starvation has stopped the engine. This usually takes a few minutes.
3. Press the engine switch to the “OFF” position.
4. Depressurize system.
5. Turn off water supply and unplug all hoses. Never start or stop the pressure washer unless the water supply is turned on.

Important: Always ensure that the fuel valve and the engine switch are in the “OFF” position when the engine is not in use.

🗨 NOTICE

If the engine will not be used for a period of two (2) weeks or longer, please see the Storage section for proper engine and fuel storage.

Operation at High Altitude

The density of air at high altitude is lower than at sea level. Engine power is reduced as the air mass and air-fuel ratio decrease. Engine power and output will be reduced approximately 3½% for every 1000 ft. (305 m) of elevation above sea level. This is a natural trend and cannot be changed by adjusting the engine. At high altitudes increased exhaust emissions can also result due to the increased enrichment of the air fuel ratio. Other high altitude issues can include hard starting, increased fuel consumption and spark plug fouling. To alleviate high altitude issues other than the natural power loss, Champion Power Equipment can provide a high altitude carburetor main jet. The alternative main jet and installation instructions can be obtained by contacting Customer Support. Installation instructions are also available in the Technical Bulletin area of the Champion Power Equipment internet site. The part number and recommended minimum altitude for the application of the high altitude carburetor main jet is listed in the table below. In order to select the correct high altitude main jet it is necessary to identify the carburetor model. For this purpose, a code is stamped on the side of the carburetor. Select the correct main jet part number corresponding to the carburetor code found on your particular carburetor.

Carburetor Code	Main Jet	Part Number	Altitude
P27-1-Z	Standard	46.131017.00.Z	5000 ft. (1524 m)
	Altitude	46.131017.00.01.Z	
P27-1-Y	Standard	46.131017.00.Y	
	Altitude	46.131017.00.01.Y	
P27-1-H	Standard	46.131017.00.H	
	Altitude	46.131017.00.01.H	

⚠ WARNING

Operation using the alternative main jet at elevations lower than the recommended minimum altitude can damage the engine. For operation at lower elevations, the standard main jet must be used. Operating the engine with the wrong engine configuration at a given altitude may increase its emissions and decrease fuel efficiency and performance.

MAINTENANCE

Make certain that the pressure washer is kept clean and stored properly. Only operate the unit on a flat, level surface in a clean, dry operating environment. DO NOT expose the unit to extreme conditions, excessive dust, dirt, moisture or corrosive vapors.

⚠ WARNING

Never operate a damaged or defective pressure washer.

⚠ WARNING

Improper maintenance will void your warranty.

🗨 NOTICE

Maintenance, replacement, or repair of emission control devices and systems may be performed by any non-road engine repair establishment or individual.

The owner/operator is responsible for all periodic maintenance. Complete all scheduled maintenance in a timely manner. Correct any issue before operating the pressure washer. For service or parts assistance, contact our help line at 1-877-338-0999.

Cleaning the Pressure Washer

⚠ CAUTION

DO NOT spray the pressure washer with water.

Water can contaminate the fuel system and can enter the engine through the cooling slots and damage the engine.

1. Use a damp cloth to clean exterior surfaces of the pressure washer.
2. Use a soft bristle brush to remove dirt and oil.
3. Use an air compressor (25 PSI) to clear dirt and debris from the pressure washer.
4. Inspect all air vents and cooling slots to ensure that they are clean and unobstructed.

Cleaning Spray Nozzle

Detach the quick connect nozzle from the wand. Use a small wire rod / paper clip (not included) to loosen up any particles in the quick connect nozzle and flush with water.

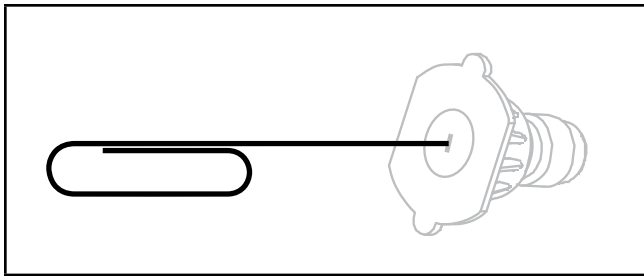

To prevent accidental starting, remove and ground spark plug wire before performing any service.

Pump Oil

Recommend type of Pump Oil:

The recommended oil is AR64516. (Annovi branded oil) If AR64516 oil is not available, Non-Detergent SAE30W oil can be used. It MUST be "non-detergent." The pump oil should be changed after the first 50 hours. Then every 250 hours after that.

1. Place an oil pan under the pump.
2. Remove the drain plug on the bottom of the pump.
3. Drain oil.
4. Replace drain plug.
5. Remove oil cap.
6. Add oil. Do not overfill.
7. Check oil level with the dipstick on the cap.

Changing the Engine Oil

Change oil when the engine is warm. Refer to the oil specification to select the proper grade of oil for your operating environment.

1. Remove the oil drain plug with a 15 mm socket (not included) and extension (not included).
2. Allow the oil to drain completely.
3. Replace the drain plug.
4. Remove oil fill cap/dipstick to add oil.

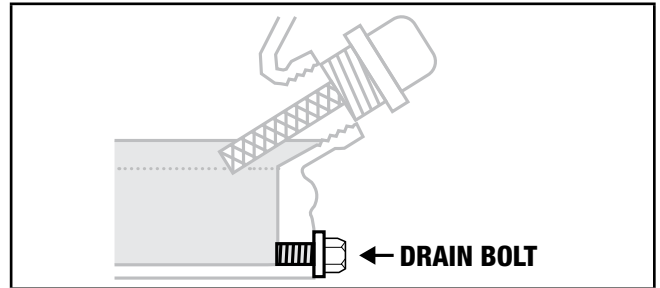

5. Add up to 37.2 fl. oz. (1.2 qt.) of oil and replace oil fill cap/dipstick. DO NOT OVERFILL.
6. Dispose of used oil at an approved waste management facility.

NOTICE

Once oil has been added, a visual check should show oil about 1-2 threads from running out of the fill hole. If using the dipstick to check oil level, DO NOT screw in the dipstick while checking.

Cleaning and Adjusting the Spark Plug(s)

1. Remove the spark plug cable from the spark plug.
2. Use a spark plug socket tool (not included), or a 21 mm (13/16 in.) (not included) socket to remove the plug.
3. Inspect the electrode on the plug. It must be clean and not worn to produce the spark required for ignition.
4. Make certain the spark plug gap is 0.7-0.8 mm (0.028-0.031 in.).

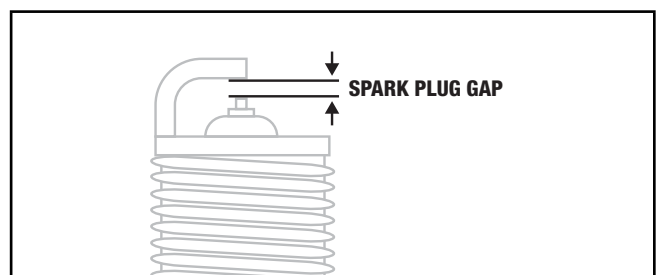

5. Refer to the spark plug types in Specifications when replacing the plug.

6. Carefully thread the plug into the engine
7. Use the spark plug socket tool (not included), or a 21 mm (13/16 in.) (not included) socket to install the plug.
8. Attach the spark plug wire to the plug.

Cleaning the Air Filter

1. Using your fingers, unscrew the thumb screws of the top holes of the air filter cover.
2. Remove the plastic outer casing.
3. Remove the foam element.
4. Wash in liquid detergent and water. Squeeze thoroughly dry in a clean cloth.
5. Saturate in clean engine oil.
6. Squeeze in a clean, absorbent cloth to remove all excess oil.
7. Place the filter in the assembly.
8. Reattach the air filter cover and using your fingers, insert the thumb screws into the top and bottom holes of the air filter cover. Screw until tight. Be sure not to over tighten.

Cleaning the Spark Arrester

1. Allow the engine to cool completely before servicing the spark arrester.
2. Remove the four (4) screws holding the cover plate which retains the end of the spark arrester to the muffler.
3. Remove the spark arrester screen.
4. Carefully remove the carbon deposits from the spark arrester screen with a wire brush.
5. Replace the spark arrester if it is damaged.
6. Position the spark arrester in the muffler and attach with the four (4) screws.

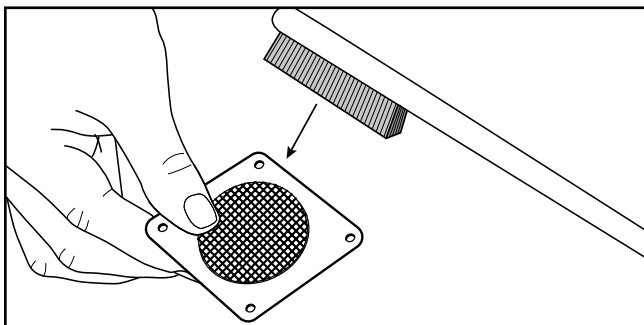

⚠ CAUTION

Failure to clean the spark arrester will result in degraded engine performance.

🗨 NOTICE

Federal and local laws and administrative requirements indicate when and where spark arresters are required. When ordered, spark arresters are required for operation of this product in National Forest lands. In California, this product must not be used on any forest-covered land, brush-covered land, or grass-covered land unless the engine is equipped with a spark arrester.

Adjusting the Governor

⚠ WARNING

Tampering with the factory set governor will void your warranty.

The air-fuel mixture is not adjustable. Tampering with the governor can damage your pressure washer and will void your warranty. CPE recommends that you contact our service line at 1-877-338-0999 for all other service and/or adjustment needs.

Maintenance Schedule

Follow the service intervals indicated in the schedule below. Service your pressure washer more frequently when operating in adverse conditions. Contact our help line at 1-877-338-0999 to locate the nearest Champion Power Equipment certified service dealer for your maintenance needs.

EVERY 8 HOURS OR DAILY

- Check oil level
- Clean around air intake and muffler

FIRST 5 HOURS

- Change oil

EVERY 50 HOURS OR EVERY SEASON

- Clean air filter
- Change oil if operating under heavy load or in hot environments

EVERY 100 HOURS OR EVERY SEASON

- Change oil
- Clean/adjust spark plug
- Check/adjust valve clearance*
- Clean spark arrester
- Clean fuel tank and filter*

EVERY 250 HOURS

- Clean combustion chamber*

EVERY 3 YEARS

- Replace fuel line*

*To be performed by knowledgeable, experienced owners or Champion Power Equipment certified dealers.

STORAGE

Refer to the Maintenance section for proper cleaning instructions.

Pressure Washer Storage

1. Allow the pressure washer to cool completely before storage.
2. Turn off the fuel supply at the fuel valve.
3. Clean the pressure washer according to the instructions in the Maintenance section.
4. Store the unit in a clean, dry area out of direct sunlight.

Engine Stored for Less than 30 Days

1. Allow the engine to cool completely before storage.
2. Clean engine according to the Maintenance section.
3. To extend the fuel storage life add a properly formulated fuel stabilizer to the tank.
4. Ensure the fuel valve is in the "OFF" position.

Engine Stored for Over 30 Days

1. Add a properly formulated fuel stabilizer to the tank.
2. Run the engine for a few minutes so the treated fuel cycles through the fuel system and carburetor.
3. Turn the fuel valve to the "OFF" position.
4. Let the engine run until fuel starvation has stopped the engine. This usually takes a few minutes.
5. The engine needs to cool completely before cleaning and storage.
6. Clean the engine according to the Maintenance section.
7. Change the oil.
8. Remove the spark plug and pour about ½ oz. (14.9 mL) of oil into the cylinder. Crank the engine slowly to distribute the oil and lubricate the cylinder.
9. Reattach the spark plug.

Winter Storage

Protect your pressure washer parts from freezing.

1. Apply all storage instructions from previous sections.
2. Make sure pressure washer hose is free of all water before storing for winter.
3. In order to prevent the pump from freezing you will need to insert RV antifreeze.
4. You will need approximately 6 oz. (177.4 mL) of RV antifreeze, a funnel, and approximately 12 in. (30.5 cm) of garden hose or equivalent. See diagram below.

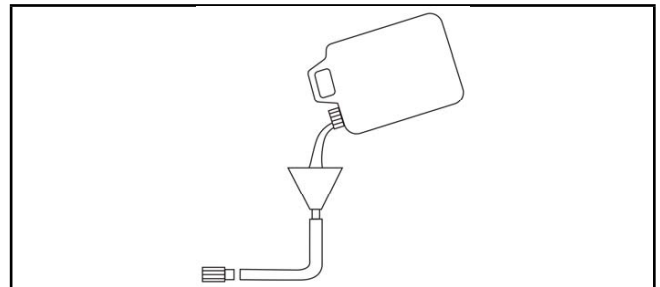

5. Pour the antifreeze into the funnel, then pull on the engine recoil starter to create suction in the pump housing. Pull the recoil several times until antifreeze comes out of the pump outlet.

⚠ WARNING

Never store the pressure washer inside or next to appliances where there is a source of heat or open flame, spark or pilot light because they can ignite gasoline vapours.

DO NOT store a pressure washer near fertilizer or any corrosive material.

Even with an empty gas tank, gasoline vapors could ignite.

⚠ DANGER

Engine exhaust contains odourless and colourless carbon monoxide gas.

To avoid accidental or unintended ignition of the product during periods of storage, the following precautions should be followed:

- When storing the pressure washer for short or long periods of time make sure that the engine switch and the fuel valve are set in the "OFF" position.

 **NOTICE**

Our engines work well with 10% or less ethanol blend fuels. When using blended fuels there are some issues worth noting:

- Ethanol-gasoline blends can absorb more water than gasoline alone.
- These blends can eventually separate, leaving water or a watery goo in the tank, fuel valve and carburetor.
- With gravity-fed fuel supplies, this compromised fuel can be drawn into the carburetor and cause damage to the engine and/or potential hazards.
- There are only a few suppliers of fuel stabilizer that are formulated to work with ethanol blend fuels.
- Any damages or hazards caused by using improper fuel, improperly stored fuel, and/or improperly formulated stabilizers, are not covered by manufacturer's warranty.

It is advisable to always shut off the fuel supply, run the engine to fuel starvation and drain the tank when the equipment is not in use for more than 30 days.

SPECIFICATIONS

Pressure Washer Specifications

Model.....	100587
Max Pressure	4400 PSI
Max Volume	3.8 GPM
Max Water Temperature	140°F (60°C)
Fuel Capacity	1.6 gal. (6.2 L)
Weight.....	137.3 lb. (62.3 kg)
Height	33.5 in. (85.2 cm)
Width	25.9 in. (65.7 cm)
Length.....	46.1 in. (117 cm)

Engine Specifications

Model.....	YF188F-000
Displacement	389 cc
Type.....	4-Stroke OHV
Start Type	Manual

Oil Specifications

DO NOT OVERFILL.

Type.....	*See chart below
Capacity	37.2 fl. oz. (1.2 qt.)

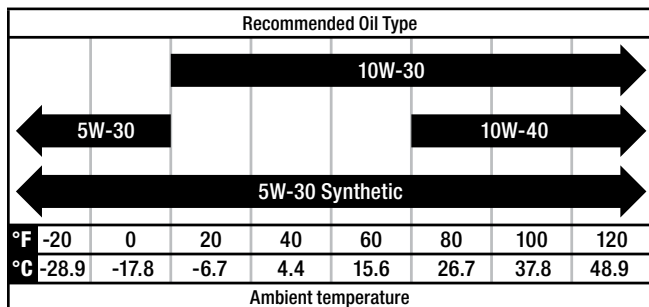

NOTICE

Weather will affect engine oil and engine performance. Change the type of engine oil used based on weather conditions to suit the engine needs.

Fuel Specifications

Use unleaded gasoline intended for motor vehicle use with a minimum octane rating of 85 or higher. Never use fuel

containing more than 10% ethanol. DO NOT USE E15 or E85. DO NOT OVERFILL.

Gasoline Capacity 1.6 gal. (6.2 L)

Spark Plug Specifications

OEM Type.....	NHSP F6RTC
Replacement Type	NGK BPR6ES or equivalent
Gap	0.7-0.8 mm (0.028-0.031 in.)

Valve Specifications

Intake Clearance	0.13-0.17 mm (0.005-0.007 in.)
Exhaust Clearance	0.18-0.22 mm (0.007-0.009 in.)

NOTICE

A technical bulletin regarding valve adjustment procedures is available at www.championpowerequipment.com.

Important Message About Temperature

Your Champion Power Equipment product is designed and rated for continuous operation at ambient temperatures up to 104°F (40°C). When your product is needed it may be operated at temperatures ranging from 5°F (-15°C) to 122°F (50°C) for short periods of time. If exposed to temperatures outside this range during storage, it should be brought back within this range before operation. In any event, the product must always be operated outdoors, in a well-ventilated area and away from doors, windows and vents.

Parts Diagram

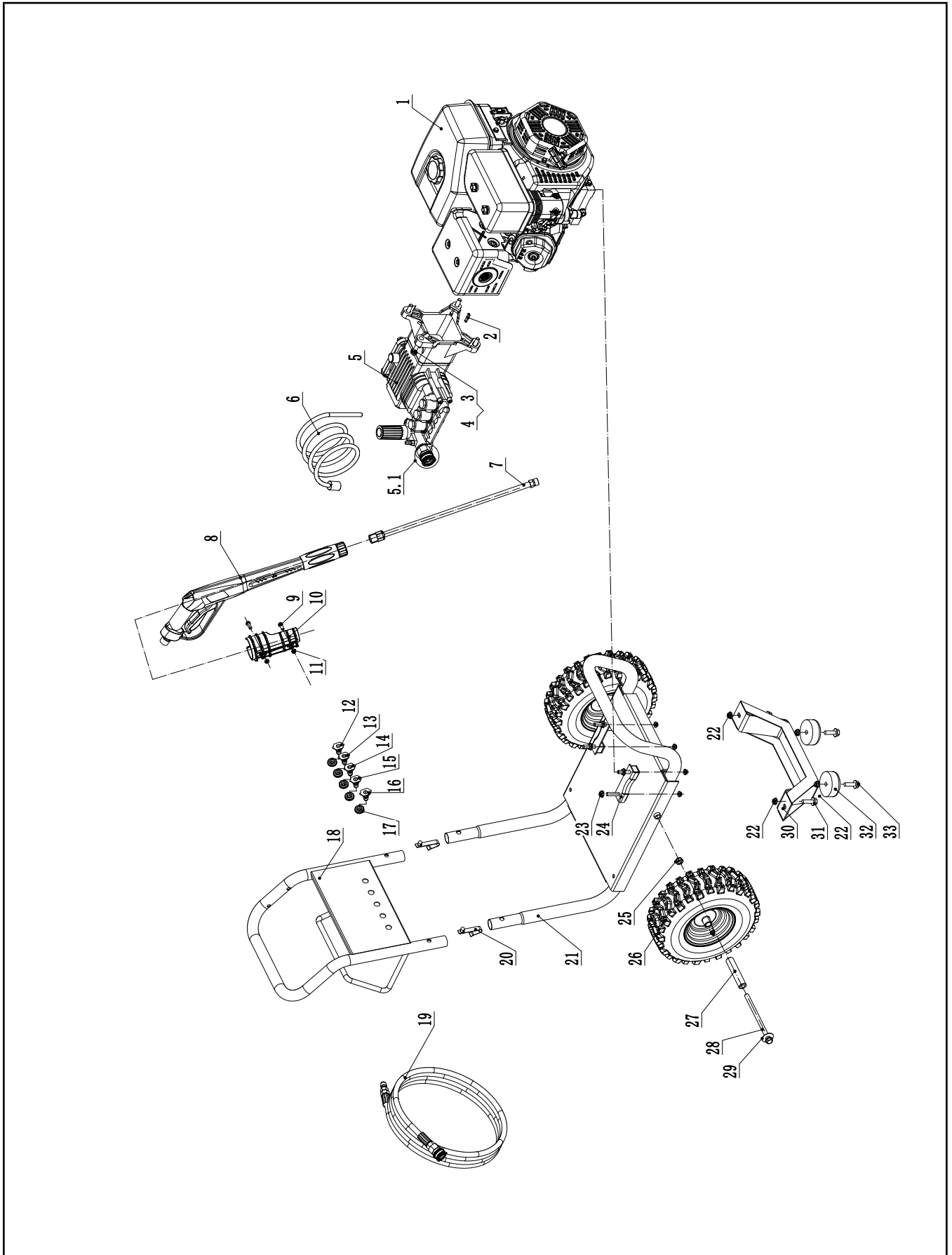

Parts List

#	Part Number	Description	Qty.
1	46.103	Engine	1
2	2.14.001	Key, SQ 4.78 x 4.78 x 40	1
3	2.08.011	Bolt 3/8-16 x 30	4
4	1.93.10	Lock Washer Ø10	4
5	255.251000.01	Pump Body	1
5.1	255.250501.00	Quick Contact, 3/8	1
6	256.250100.01	Detergent Hose, 47.2 in.	1
7	255.252200.01	Wand	1
8	255.252100.00.48	Handle, Gun	1
9	1.5783.0645	Bolt M6 x 45	2
10	254.200012.05.2	Shelf, Hose	1
11	1.6177.1.06	Lock Nut M6, Flange	2
12	254.252300.05	Nozzle"Detergent", 65400	1
13	253.252300.03	Nozzle"40", 40040	1
14	253.252300.02	Nozzle"25", 25040	1
15	253.252300.01	Nozzle"15", 15040	1
16	253.252300.00	Nozzle"0", 00040	1
17	252.201400.01	Sheath, Nozzle	5
18	253.200701.02.78	Handle	1

#	Part Number	Description	Qty.
19	255.250100.05	High-Pressure Hose, 50ft.	1
20	252.201300.00	Pin	2
21	253.201100.02.78	Frame	1
22	1.6177.1.08	Lock Nut M8, Flange	8
23	1.6177.1.10	Lock Nut M10, Flange	4
24	253.201200.00	Vibration Mount, Engine	2
25	1.6182.10	Lock Nut M10	2
26	255.201701.00.48	13 in. Pneumatic Wheel, Yellow	2
27	255.200016.01	Bushing Ø19 x Ø10.5 x 99	2
28	1.5782.10165	Bolt M10x165	2
29	1.96.10	Washer Ø10	2
30	253.200002.01.78	Support Leg, 125 mm	1
31	1.5789.0855	Flange Bolt M8 x 55	2
32	152.201400.00	Vibration Mount, Support Leg	2
33	1.5789.0825	Flange Bolt M8 x 25	2

Engine Parts Diagram

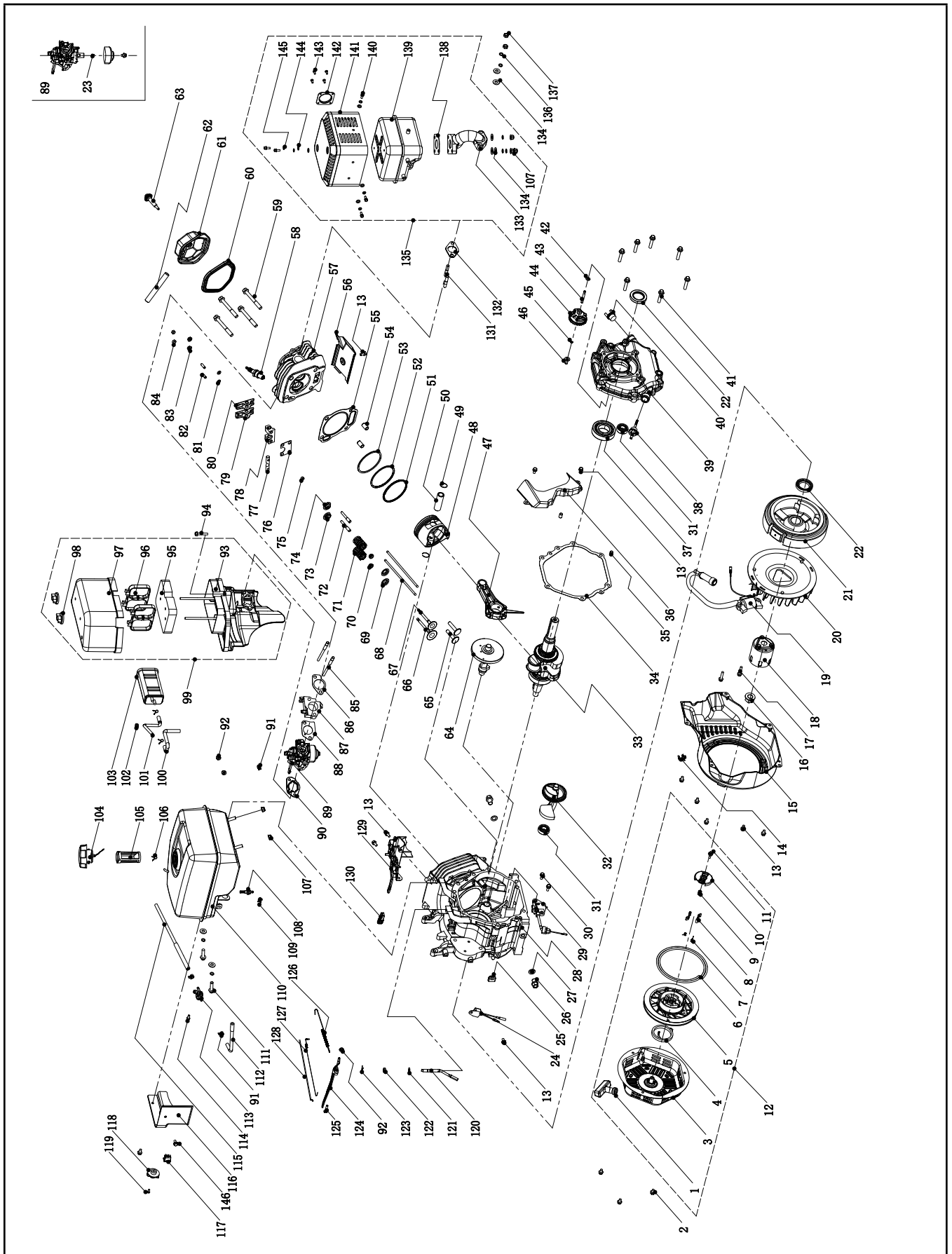

Engine Parts List

#	Part Number	Description	Qty.
1	21.061300.00	Handle, Recoil, Soft	1
2	1.5789.0608	Flange Bolt M6 x 8	3
3	46.061100.00.2	Cover, Recoil Starter, Black	1
4	45.060005.00	Spring, Recoil Starter	1
5	45.061102.00	Reel, Recoil Starter	1
6	2.10.003.1	Rope Ø4 x 1550, Black	1
7	45.060003.00	Spring, Ratchet	2
8	45.060002.00	Starter Ratchet, Steel	2
9	45.060009.00	Spring, Ratchet Guide	1
10	45.060007.00	Ratchet Guide	1
11	45.060008.00	Screw, Ratchet Guide	1
12	46.061000.00	Recoil Assembly	1
13	1.5789.0612	Flange Bolt M6 x 12	11
14	2.05.003	Clamp Ø11.5 x 10	1
15	46.080100.00.48	Fan Cover, Yellow	1
16	2.02.007	Nut M16 x 1.5	1
17	1.5789.0629	Flange Bolt M6 x 29	2
18	45.060001.00	Pulley, Starter	1
19	46.123000.01	Ignition Coil	1
20	45.080001.00	Cooling Fan	1
21	46.120100.03	Flywheel	1
22	2.11.007	Oil Seal Ø35 x Ø52 x 8	2
23	46.131017.00	Main Jet, Standard	1
	46.131017.00.01	Main Jet, Altitude	/
24	21.120400.01	Diode Assembly	1
25	45.030032.00	Sheath, Wire	1
26	2.08.039	Drain Bolt M12 x 1.25 x 25	2
27	2.03.023	Washer Ø12.5 x Ø20 x 2, Drain Bolt	2
28	46.030100.01	Crankcase	1
29	45.127000.02	Oil Level Sensor	1
30	1.5789.0615	Flange Bolt M6 x 15	2
31	1.276.6202	Bearing 6202	2
32	47.050006.00	Weight Balancer	1
33	45.050100.09	Crankshaft, U	1
34	46.030008.00	Gasket, Crankcase Cover	1
35	2.04.001	Dowel Pin Ø9 x 14	2
36	46.080600.00	Air Guide, Right Side	1
37	1.276.6207	Bearing 6207	1
38	46.031000.00.48	Oil Dipstick Assembly, Yellow	1

#	Part Number	Description	Qty.
39	45.030007.01	Cover, Crankcase	1
40	22.031000.01.48	Oil Filler Cap, Yellow	1
41	1.5789.0840.0.8	Flange Bolt M8 x 40	7
42	2.03.021.1	Washer Ø6.4 x Ø13 x 1, Black	1
43	45.110013.00	Shaft, Governor Gear	1
44	45.110100.00	Gear, Governor	1
45	21.110011.00	Clip, Governor Gear	1
46	45.110012.00	Bushing, Governor Gear	1
47	47.050200.00	Connecting Rod	1
48	46.050005.00	Piston	1
49	2.09.004	Circlip Ø21 x Ø1	2
50	45.050003.00	Pin, Piston	1
51	46.050303.00	Ring, Oil	1
52	46.050302.00	Ring, Second Piston	1
53	46.050301.00	Ring, First Piston	1
54	2.04.004	Dowel Pin Ø12 x 20	2
55	46.030009.01	Gasket, Cylinder Head	1
56	46.080400.00	Air Guide, Lower	1
57	46.010100.00	Cylinder Head	1
58	2.15.002(F6RTC)	Spark Plug F6RTC	1
59	2.08.014	Flange Bolt M10 x 80	4
60	46.020002.00	Gasket, Cylinder Head Cover	1
61	46.021000.00	Cover, Cylinder Head	1
62	45.020001.00	Breather Tube	1
63	45.020100.00	Bolt, Cylinder Head Cover	1
64	46.041000.00	Camshaft	1
65	45.040013.00	Lifter, Valve	2
66	45.040002.00	Valve, Intake	1
67	45.040006.00	Valve, Exhaust	1
68	46.040005.00	Push Rod	2
69	45.040015.00	Retainer, Valve Spring	2
70	45.040017.00	Oil Seal, Valve	2
71	45.040003.00	Spring, Valve	2
72	23.040010.00	Bolt, Rocker Arm	2
73	45.040001.00	Retainer, Intake Valve Spring	1
74	45.040007.00	Retainer, Exhaust Valve Spring	1
75	45.040008.00	Rotator, Exhaust Valve	1
76	46.040004.00	Guide Plate, Push Rod	1
77	46.040016.00	Shaft, Rocker Arm	1

#	Part Number	Description	Qty.
78	46.040201.00	Retainer, Rocker Arm	1
79	46.040009.00	Rocker Arm, Intake Valve	1
80	46.040018.00	Rocker Arm, Exhaust Valve	1
81	1.97.1.06	Washer Ø6	2
82	22.040012.00	Screw, Valve Adjustment	2
83	1.6177.1.06	Flange Nut M6	2
84	21.040021.00	Nut M6 x 0.5, Lock	2
85	2.01.013	Stud Bolt M6 x M8 x 131	2
86	46.130002.20	Gasket, Insulator	1
87	45.130001.00	Insulator, Carburetor	1
88	46.130003.20	Gasket, Carburetor	1
89	46.131000.00	Carburetor	1
	46.131000.04		
90	45.130004.00	Gasket, Air Cleaner	1
91	2.06.007	Clamp Ø8 x b6	3
92	1.6177.06	Flange Nut M6	3
93	46.091100.01	Base, Air Cleaner	1
94	1.5789.0633	Flange Bolt M6 x 33	1
95	46.091003.02	Element, Air Cleaner	1
96	46.091102.02	Supporter, Air Cleaner	2
97	46.091200.02	Cover, Air Cleaner	1
98	46.091600.01	Screw Cap, Air Cleaner Cover	2
99	46.091000.02	Air Cleaner Assembly	1
100	46.070013.00	Pipe, Air Cleaner	1
101	46.070014.00	Pipe	1
102	2.12.001	Buffer Ø7.5 x 7.5	1
103	46.070700.00	Carbon Canister 150CC	1
104	24.070100.02	Fuel Tank Cap	1
105	46.070300.00	Fuel Filter Component, Large	1
106	2.06.006	Clamp Ø7 x Ø1	3
107	1.6187.1.08	Nut M8	5
108	21.070600.03	Connect, Zinc Alloy	1
109	2.06.016	Clip Ø8.7 x b8	1
110	46.071000.01.2	Fuel Tank, Black	1
111	1.5789.0832	Flange Bolt M8 x 32	2
112	46.070011.00	Pipe, Fuel Tank To Fuel Valve	1
113	24.070400.00	Fuel Valve	1
114	1.16674.0512.2	Flange Bolt M5 x 12	1

#	Part Number	Description	Qty.
115	46.070011.01	Pipe, Fuel Valve To Carburetor	1
116	46.070010.00	Fuel Tank Veil	1
117	5.1010.003.3	Ignition Switch, Red	1
118	24.070001.00	Knob, Fuel Valve	1
119	1.818.0412	Bolt M4X12	1
120	45.110001.00	Shaft, Governor Arm	1
121	2.03.019	Washer Ø8.2 x Ø17 x 0.8	1
122	2.11.006	Oil Seal Ø7 x Ø14 x 5	1
123	45.110008.00	Pin, Shaft	1
124	45.110003.00	Arm, Governor	1
125	2.08.040	Bolt M6 x 21, Governor Arm	1
126	45.110007.00	Spring, Governor	1
127	45.110005.00	Spring, Throttle Return	1
128	45.110006.00	Rod, Governor	1
129	46.080300.00	Air Guide, Upper	1
130	24.111008.01.48	Sheath, Grip	1
131	2.01.005	Stud Bolt M8 x 49	2
132	46.100001.07	Gasket, Exhaust Pipe	1
133	46.101001.05	Exhaust Pipe	1
134	1.848.08	Washer Ø8	7
135	46.101000.05.2	Muffler Assembly	1
136	1.93.08	Lock Washer Ø8	7
137	1.6175.08	Nut M8	2
138	46.101002.05	Washer, Muffler	1
139	46.101100.05	Muffler	1
140	1.16674.0510	Flange Bolt M5 x 10	5
141	46.101202.05	Muffler Protector	1
142	46.101300.05	Muffler Screen	1
143	1.818.046	Screw M4 x 6	4
144	1.848.05	Washer Ø5	5
145	1.859.05	Lock Washer Ø5	5
146	23.120700.02	Change Wire flameout	1

Troubleshooting

Problem	Cause	Solution
Pressure washer will not start.	No fuel.	Add fuel.
	Faulty spark plug.	Replace spark plug.
Pressure washer will not start; Pressure washer starts but runs roughly.	Low oil level.	Fill crankcase to the proper level. Place pressure washer on a flat, level surface.
	Choke in the wrong position.	Adjust choke.
	Spark plug wire loose.	Attach wire to spark plug.
Pressure washer gallops.	Engine governor defective.	Contact the help line.
Unit does not reach high pressure.	Water supply is restricted.	Check hoses for leaks, blockage, kinks.
	Garden hose is too small.	Replace with 5/8 in. (16 mm) garden hose or larger.
	Garden hose inlet filter is clogged.	Remove garden hose, clean filter and rinse out.
	Not enough inlet water.	Turn garden hose water on full force.
Spray pressure varies from high to low.	Poor inlet water supply.	Turn garden hose water on full force. Check hose for leaks, blockage, or kinks.
	Garden hose inlet filter is clogged.	Remove garden hose, clean filter and rinse out.
	Spray nozzle is obstructed.	Remove particles with small wire rod (see maintenance section in manual).
	Pump is sucking air.	Check all hoses and fittings, make sure they are securely tightened down and fastened. Turn off engine and purge pump by squeezing trigger gun until a steady stream of water flows.
Low-pressure detergent wash is not functioning properly.	Detergent is too thick.	Dilute detergent
	Spray wand has high pressure quick connect nozzle installed.	Detergent only works with low pressure quick connect nozzle (black).
	Detergent hose is not connected to the pump housing.	Check connection.
	Spray nozzle is obstructed.	Clean nozzle and remove debris.
	Filter on detergent hose is clogged.	Clean with warm water or replace.
	Chemical Injector valve (inside pump) partially blocked or stuck.	Quickly pull and release the gun trigger 4-5 times to clear the chemical injector valve.
	Detergent tube not connected to the brass fitting on the pump outlet.	Install detergent tube to detergent injector inlet near pump outlet.
Garden hose connection leaks.	Loose fittings.	Tighten.
	Missing/worn-out rubber washer.	Replace rubber washer.
Spray wand leaks	Spray wand not properly attached.	Tighten all connections.
Can't pull recoil	Pump will build pressure with each pull.	Pull gun trigger after 2 pulls of recoil, to release pump pressure.

For further technical support:

Technical Service

Mon – Fri 8:30 AM – 5:00 PM (PST/PDT)

Toll Free: 1-877-338-0999

tech@championpowerequipment.com

WARRANTY*

CHAMPION POWER EQUIPMENT
2 YEAR LIMITED WARRANTY

Warranty Qualifications

To register your product for warranty and FREE lifetime call center technical support please visit:

<https://www.championpowerequipment.com/register>

To complete registration you will need to include a copy of the purchase receipt as proof of original purchase. Proof of purchase is required for warranty service. Please register within ten (10) days from date of purchase.

Repair/Replacement Warranty

CPE warrants to the original purchaser that the mechanical and electrical components will be free of defects in material and workmanship for a period of two years (parts and labor) from the original date of purchase and 180 days (parts and labor) for commercial and industrial use. Transportation charges on product submitted for repair or replacement under this warranty are the sole responsibility of the purchaser. This warranty only applies to the original purchaser and is not transferable.

Do Not Return The Unit To The Place Of Purchase

Contact CPE's Technical Service and CPE will troubleshoot any issue via phone or e-mail. If the problem is not corrected by this method, CPE will, at its option, authorize evaluation, repair or replacement of the defective part or component at a CPE Service Center. CPE will provide you with a case number for warranty service. Please keep it for future reference. Repairs or replacements without prior authorization, or at an unauthorized repair facility, will not be covered by this warranty.

Warranty Exclusions

This warranty does not cover the following repairs and equipment:

Normal Wear

Products with mechanical and electrical components need periodic parts and service to perform well. This warranty does not cover repair when normal use has exhausted the life of a part or the equipment as a whole.

Installation, Use and Maintenance

This warranty will not apply to parts and/or labor if the product is deemed to have been misused, neglected, involved in an accident, abused, loaded beyond the product's limits, modified, installed improperly or connected incorrectly to any electrical component. Normal maintenance is not covered by this warranty and is not required to be performed at a facility or by a person authorized by CPE.

Other Exclusions

This warranty excludes:

- Cosmetic defects such as paint, decals, etc.
- Wear items such as filter elements, o-rings, etc.
- Accessory parts such as starting batteries, and storage covers.
- Failures due to acts of God and other force majeure events beyond the manufacturer's control.
- Problems caused by parts that are not original Champion Power Equipment parts.

When applicable, this warranty does not apply to products used for prime power in place of a utility.

Limits of Implied Warranty and Consequential Damage

Champion Power Equipment disclaims any obligation to cover any loss of time, use of this product, freight, or any incidental or consequential claim by anyone from using this product. THIS WARRANTY AND THE ATTACHED U.S. EPA, CARB and/or ECCC EMISSION CONTROL SYSTEM WARRANTIES (WHEN APPLICABLE) ARE IN LIEU OF ALL OTHER WARRANTIES, EXPRESS OR IMPLIED, INCLUDING WARRANTIES OF MERCHANTABILITY OR FITNESS FOR A PARTICULAR PURPOSE.

A unit provided as an exchange will be subject to the warranty of the original unit. The length of the warranty governing the exchanged unit will remain calculated by reference to the purchase date of the original unit.

This warranty gives you certain legal rights which may change from state to state or province to province. Your state or province may also have other rights you may be entitled to that are not listed within this warranty.

Contact Information

Address

Champion Power Equipment, Inc.
Customer Service
12039 Smith Ave.
Santa Fe Springs, CA 90670 USA
www.championpowerequipment.com

Customer Service

Mon – Fri 8:30 AM – 5:00 PM (PST/PDT)
Toll Free: 1-877-338-0999
info@championpowerequipment.com
Fax no.: 1-562-236-9429

Technical Service

Mon – Fri 8:30 AM – 5:00 PM (PST/PDT)
Toll Free: 1-877-338-0999
tech@championpowerequipment.com
24/7 Tech Support: 1-562-204-1188

*Except as otherwise stipulated in any of the following enclosed Emission Control System Warranties (when applicable) for the Emission Control System: U.S. Environment Protection Agency (EPA), California Air Resources Board (CARB) and/or Environment and Climate Change Canada (ECCC).

**Champion Power Equipment, Inc. (CPE),
The United States Environment Protection Agency (U.S. EPA.) and the California Air Resources Board (CARB)
Emission Control System Warranty**

Your Champion Power Equipment (CPE) engine complies with both the U.S. EPA and state of California Air Resources Board (CARB) emission regulations.

YOUR WARRANTY RIGHTS AND OBLIGATIONS:

The US EPA, California Air Resources Board, and CPE are pleased to explain the Federal and California Emission Control Systems Warranty on your 2018 small off-road engine (SORE) and engine powered equipment. In California, new, small off-road engines (SORE) and new equipment that use small off-road engines (SORE) must be designed, built and equipped to meet the State's stringent anti smog standards. In the other states, new engines and equipment must be designed, built and equipped, at the time of sale, to meet U.S. EPA regulations for small off-road engines (SORE). CPE warrants the emission control system on your small off-road engine (SORE) and equipment for the period of time listed below, provided there has been no abuse, neglect, unapproved modification, or improper maintenance of your equipment.

Your emission control system may include parts such as the carburetor, fuel-injection system, the ignition system, catalytic converter and fuel lines. Also included may be hoses, belts, connectors and other emission related assemblies. Where a warrantable condition exists, CPE will repair your small off-road engine (SORE) at no cost to you including diagnosis, parts and labor. For engines less than or equal to 80cc, only the fuel tank and fuel line is subject to the evaporative emission control warranty requirements of this section.

MANUFACTURER'S EMISSION CONTROL SYSTEM WARRANTY COVERAGE:

This emission control system is warranted for two years, subject to provisions set forth below. If, during the warranty period, emission related part on your engine is defective in materials or workmanship, the part will be repaired or replaced by CPE.

OWNER WARRANTY RESPONSIBILITIES:

As the small off-road engine (SORE) owner, you are responsible for the performance of the required maintenance listed in your Owner's Manual. CPE recommends that you retain all your receipts covering maintenance on your small off-road engine (SORE), but CPE cannot deny warranty solely for the lack of receipts or for your failure to ensure the performance of all scheduled maintenance.

As the small off-road engine (SORE) owner, you should however be aware that CPE may deny you warranty coverage if your small, off-road engine (SORE) or a part has failed due to abuse, neglect, improper maintenance or unapproved modifications.

You are responsible for presenting your small off-road engine to an Authorized CPE service outlet or alternate service outlet as described in (3)(f.) below, CPE dealer or CPE, Santa Fe Springs, Ca. as soon as a problem exists. The warranty repairs should be completed in a reasonable amount of time, not to exceed 30 days.

If you have any questions regarding your warranty rights and responsibilities, you should contact:

Champion Power Equipment, Inc.
Customer Service
12039 Smith Ave.
Santa Fe Springs, CA 90670
1-877-338-0999
tech@championpowerequipment.com

EMISSION CONTROL SYSTEM WARRANTY

The following are specific provisions relative to your Emission Control System (ECS) Warranty Coverage.

1. APPLICABILITY: This warranty shall apply to 1995 and later model year California small off-road engines (SORE) (for other states, 1997 and later model year engines). The ECS Warranty Period shall begin on the date the new engine or equipment is delivered to its original, end-use purchaser, and shall continue for 24 consecutive months thereafter.

2. GENERAL EMISSIONS WARRANTY COVERAGE

CPE warrants to the original, end-use purchaser of the new engine or equipment and to each subsequent purchaser that each of its small off-road engines (SORE) is:

a. Designed, built and equipped so as to conform to U.S. EPA emissions standards for spark-ignited engines at or below 19 kilowatts and all applicable regulations adopted by the California Air Resources Board and

b. Free from defects in materials and workmanship that cause the failure of a warranted part to be identical in all material respects to the part as described in the engine manufacturer's application for certification for a period of two years.

3. THE WARRANTY ON EMISSION-RELATED PARTS WILL BE INTERPRETED AS FOLLOWS:

a. Any warranted part that is not scheduled for replacement as required maintenance in the Owners Manual shall be warranted for the ECS Warranty Period. If any such part fails during the ECS Warranty Period, it shall be repaired or replaced by CPE according to Subsection "d" below. Any such part repaired or replaced under the ECS Warranty shall be warranted for any remainder of the ECS Warranty Period.

b. Any warranted, emissions-related part which is scheduled only for regular inspection as specified in the Owners Manual shall be warranted for the ECS Warranty Period. A statement in such written instructions to the effect of "repair or replace as necessary", shall not reduce the ECS Warranty Period. Any such part repaired or replaced under the ECS Warranty shall be warranted for the remainder of the ECS Warranty Period.

c. Any warranted, emissions-related part which is scheduled for replacement as required maintenance in the Owner's Manual shall be warranted for the period of time prior to the first scheduled replacement point for that part. If the part fails prior to the first scheduled replacement, the part shall be repaired or replaced by CPE according to Subsection "d" below. Any such emissions-related part repaired or replaced under the ECS Warranty, shall be warranted for the remainder of the ECS Warranty Period prior to the first scheduled replacement point for such emissions-related part.

d. Repair or replacement of any warranted, emissions-related part under this ECS Warranty shall be performed at no charge to the owner at a CPE Authorized Service Outlet.

e. The owner shall not be charged for diagnostic labor which leads to the determination that a part covered by the ECS Warranty is in fact defective, provided that such diagnostic work is performed at a CPE Authorized Service Outlet.

f. CPE shall pay for covered emissions warranty repairs at non-authorized service outlets under the following circumstances:

i. The service is required in a population center with a population over 100,000 according to U.S. Census 2000 without a CPE Authorized Service Outlet AND

ii. The service is required more than 100 miles from a CPE Authorized Service Outlet. The 100 mile limitation does not apply in the following states: Alaska, Arizona, Colorado, Hawaii, Idaho, Montana, Nebraska, Nevada, New Mexico, Oregon, Texas, Utah and Wyoming.

g. CPE shall be liable for damages to other original engine components or approved modifications proximately caused by a failure under warranty of an emission-related part covered by the ECS Warranty.

h. Throughout the ECS Warranty Period, CPE shall maintain a supply of warranted emission-related parts sufficient to meet the expected demand for such emission-related parts.

i. Any CPE Authorized and approved emission-related replacement part may be used in the performance of any ECS Warranty maintenance or repair and will be provided without charge to the owner. Such use shall not reduce CPE's warranty obligation.

j. Unapproved add-on or modified parts may not be used to modify or repair a CPE engine. Such use voids this ECS Warranty and shall be sufficient grounds for disallowing an ECS Warranty claim. CPE shall not be liable hereunder for failures of any warranted parts of a CPE engine caused by the use of such an unapproved add-on or modified part.

EMISSION-RELATED PARTS INCLUDE THE FOLLOWING: (using those portions of the list applicable to the engine)

Systems covered by this warranty	Parts Description
Fuel Metering System	Fuel regulator, Carburetor and internal parts
Air Induction System	Air cleaner, Intake manifold
Ignition System	Spark plug and parts, Magneto ignition system
Exhaust System	Exhaust manifold, catalytic converter
Miscellaneous Parts	Tubing, Fittings, Seals, Gaskets, and Clamps associated with these listed systems.
Evaporative Emissions	Fuel Tank, Fuel Cap, Fuel Line (for liquid fuel and fuel vapors), Fuel Line Fittings, Clamps, Pressure Relief Valves, Control Valves, Control Solenoids, Electronic Controls, Vacuum Control Diaphragms, Control Cables, Control Linkages, Purge Valves, Gaskets, Vapor Hoses, Liquid/Vapor Separator, Carbon Canister, Canister Mounting Brackets, Carburetor Purge Port Connector

TO OBTAIN WARRANTY SERVICE:

You must take your CPE engine or the product on which it is installed, along with your warranty registration card or other proof of original purchase date, at your expense, to any Champion Power Equipment dealer who is authorized by Champion Power Equipment, Inc. to sell and service that CPE product during his normal business hours. Alternate service locations defined in Section (3)(f.) above must be approved by CPE prior to service. Claims for repair or adjustment found to be caused solely by defects in material or workmanship will not be denied because the engine was not properly maintained and used.

If you have any questions regarding your warranty rights and responsibilities, or to obtain warranty service, please write or call Customer Service at Champion Power Equipment, Inc.

**Champion Power Equipment, Inc.
12039 Smith Ave.
Santa Fe Springs, CA 90670
1-877-338-0999
Attn.: Customer Service
tech@championpowerequipment.com**