



OPERATOR'S MANUAL

MODEL #100641
CHAINSAW



REGISTER YOUR PRODUCT ONLINE

at championpowerequipment.com

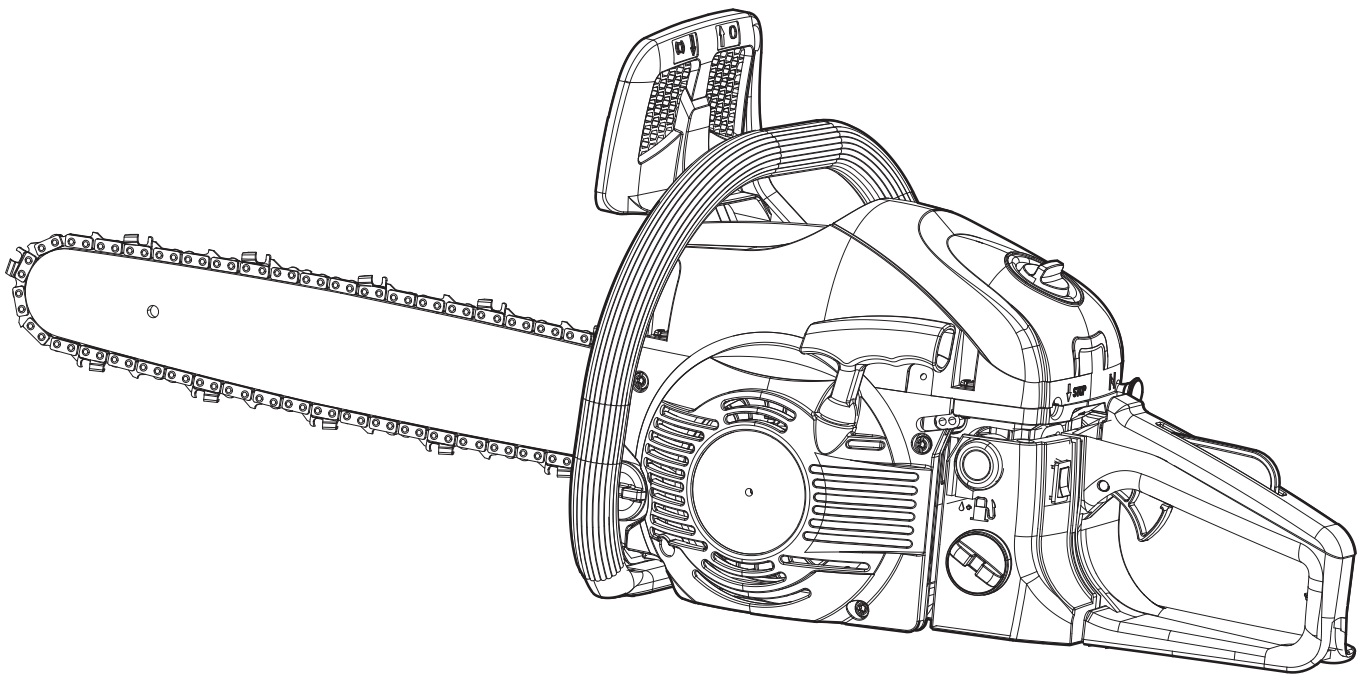

Intertek



1-877-338-0999

or visit championpowerequipment.com

READ AND SAVE THIS MANUAL. This manual contains important safety precautions which should be read and understood before operating the product. Failure to do so could result in serious injury. This manual should remain with the product.

Specifications, descriptions and illustrations in this manual are as accurate as known at the time of publication, but are subject to change without notice.

TABLE OF CONTENTS

Introduction	3	Maintenance	22
Safety Definitions	3	Maintenance Schedule	22
Important Safety Instructions	4	Adding Bar and Chain Oil	22
Fuel Safety	4	Adjusting the Bar And Chain Oil Flow	23
While Operating	4	Adjusting the Chain Tension	23
Kickback Safety	6	Removing and Installing the Guide Bar and Saw Chain	24
Other Safety Warnings	7	Maintaining the Saw Chain	26
Safety Labels	8	Sharpening the Saw Chain	26
Safety Symbols	9	Maintaining the Guide Bar	27
Quickstart Label Symbols	10	Lubricating the Guide Bar Sprocket Tip	27
Controls and Features	11	Replacing the Guide Bar and Saw Chain	28
Chainsaw	11	Maintaining the Air Filter	28
Safety Features	12	Adjusting the Idle Speed	29
Assembly	13	Maintaining the Spark Plug	29
Adding Bar and Chain Oil: Initial Use	13	Cleaning	30
Adjusting the Chain Tension: Initial Use	13	Storage	30
Oil and Fuel Mixing Instructions	13	Long-term Storage (30 days or more)	31
Operation	14	Preparing the Chainsaw for Use after Long-term Storage	31
Starting and Stopping	14	Specifications	32
Tips for Best Results	16	Chainsaw Specifications	32
Preparing the Work Area	16	Replacement Parts	32
Holding the Chainsaw	17	Troubleshooting	33
Wedges and Recommended Tools	17		
Cutting Procedure Basics	18		
Felling: Safety	18		
Felling: Procedure	18		
Limbing	20		
Bucking: Safety	20		
Bucking: Procedure	20		
Pruning	21		

INTRODUCTION

Congratulations on your purchase of a Champion Power Equipment (CPE) product. CPE designs, builds, and supports all of our products to strict specifications and guidelines. With proper product knowledge, safe use, and regular maintenance, this product should bring years of satisfying service.

Every effort has been made to ensure the accuracy and completeness of the information in this manual at the time of publication, and we reserve the right to change, alter and/or improve the product and this document at any time without prior notice.

Since CPE highly values how our products are designed, manufactured, operated and are serviced, and also highly value your safety and the safety of others, we would like you to take the time to review this product manual and other product materials thoroughly and be fully aware and knowledgeable of the assembly, operation, dangers and maintenance of the product before use. Fully familiarize yourself, and make sure others who plan on operating the product fully familiarize themselves too, with the proper safety and operation procedures before each use. Please always exercise common sense and always err on the side of caution when operating the product to ensure no accident, property damage, or injury occurs. We want you to continue to use and be satisfied with your CPE product for years to come.

When contacting CPE about parts and/or service, you will need to supply the complete model and serial numbers of your product. Transcribe the information found on your product's nameplate label to the table below

CPE TECHNICAL SUPPORT TEAM
1-877-338-0999
MODEL NUMBER
100641
SERIAL NUMBER
DATE OF PURCHASE
PURCHASE LOCATION

SAFETY DEFINITIONS

The purpose of safety symbols is to attract your attention to possible dangers. The safety symbols, and their explanations, deserve your careful attention and understanding. The safety warnings do not by themselves eliminate any danger. The instructions or warnings they give are not substitutes for proper accident prevention measures.

DANGER

DANGER indicates a hazardous situation which, if not avoided, will result in death or serious injury.

WARNING

WARNING indicates a hazardous situation which, if not avoided, could result in death or serious injury.

CAUTION

CAUTION indicates a hazardous situation which, if not avoided, could result in minor or moderate injury.

NOTICE

NOTICE indicates information considered important, but not hazard-related (e.g., messages relating to property damaged).

IMPORTANT SAFETY INSTRUCTIONS

Read all instructions before operating.

WARNING

When using the chainsaw, all safety rules must be followed. Always read these instructions before operating the chainsaw in order to ensure the safety of the operator and any bystanders. Always keep these instructions for later use.

- Read the instructions carefully. Be familiar with the controls and proper use of the chainsaw. Know how to stop the chainsaw and disengage the controls quickly.
- Never operate this chainsaw when tired, ill or under the influence of alcohol, drugs or medication.
- Never allow children to operate the chainsaw. Never operate the chainsaw without proper instruction.
- All guards and safety attachments must be installed properly before operating the chainsaw.
- Always inspect the chainsaw before use. Replace damaged parts. Check for fuel leaks. Make sure all fasteners are in place and secure. Replace parts that are cracked, chipped, or damaged.
- Do not operate the chainsaw with loose or damaged parts.
- Always be aware of risk of injury to the head, hands and feet.
- Carefully inspect the area before starting the chainsaw. Remove rocks, broken glass, nails, wire, string and other objects that may be thrown or become entangled with the chainsaw.
- Clear the area of children, bystanders and pets; keep them outside a 50 ft. (15m) radius, at a minimum. Even then, they are still at risk from thrown objects and falling branches. Encourage bystanders to wear eye protection. If you are approached, stop the chainsaw immediately.
- Squeeze the throttle control and check that it returns automatically to the idle position.
- Make adjustments or repairs before using the chainsaw.

Fuel Safety

DANGER

GASOLINE AND GASOLINE VAPORS ARE HIGHLY FLAMMABLE AND EXPLOSIVE.

Fire or explosion can cause severe burns or death.

Gasoline and gasoline vapors:

- Gasoline is highly flammable and explosive.
- Gasoline can cause a fire or explosion if ignited.
- Gasoline is a liquid fuel but it's vapors can ignite.
- Gasoline is a skin irritant and needs to be cleaned up immediately if spilled on skin or clothes.
- Gasoline has a distinctive odor, this will help detect potential leaks quickly.
- Gasoline expands or contracts with ambient temperatures. Never fill the gasoline tank to full capacity, as gasoline needs room to expand when temperatures rise.
- Store gasoline only in fuel containers specifically designed and approved for the storage of gasoline.
- Always stop the engine and allow it to cool before filling the fuel tank. Never remove the fuel tank cap or add fuel when the engine is hot. Always loosen the fuel tank cap slowly to relieve any pressure in the fuel tank before fueling.
- Always mix and add fuel in a clean, well-ventilated outdoor area where there are no sparks or flames. DO NOT smoke.
- Never operate the chainsaw without the fuel cap securely in place.
- Avoid creating a source of ignition for spilled fuel. Wipe up any spilled fuel from the chainsaw immediately, before starting the chainsaw. Move the chainsaw at least 50 ft. (15 m) from the fueling source location before starting the chainsaw. DO NOT smoke.
- Never start or run the chainsaw inside a closed room or building. Breathing exhaust fumes can kill. Operate this chainsaw only in a well ventilated outdoor area.

While Operating

- When a chainsaw is being used, a fire extinguisher should be readily available.
- Wear safety glasses or goggles that meet current ANSI Z87.1 standards and are marked as such. Wear ear/hearing protection when operating this chainsaw. Wear a face mask or dust mask if the operation is dusty. Use a hard hat or other type of safety helmet.

- Wear safety boots and protective gloves. Wear heavy, snug fitting clothes, including long pants and a long-sleeve shirt. Do not wear loose clothing, jewelry, short pants, sandals or go barefoot. Always secure hair above shoulder level.
- Make sure the saw chain is not in contact with anything before starting the chainsaw.
- Use the chainsaw only in daylight or good artificial light.
- Avoid accidental starting. Be in the starting position whenever pulling the starter rope. The operator and chainsaw must be in a stable position while starting. Refer to Starting and Stopping instructions.
- Only use this chainsaw for its intended purpose: to cut wood. Do not use the chainsaw for cutting plastic, masonry or other non-wood building materials. Only use the chainsaw as described in this manual.
- Keep all body parts away from the saw chain when the chainsaw is running. Do not touch or try to stop moving parts with your hands.
- When carrying a chainsaw with the engine running, always engage the chain brake.
- Do not touch the engine or muffler. These parts get extremely hot from operation, even after the chainsaw is turned off.
- Do not operate the chainsaw faster than the speed needed to do the job. Do not run the chainsaw at high speed when not in use.
- Do not force the chainsaw, especially near the end of a cut. It will do a better, safer job when used at the intended rate of speed.
- Always turn the engine off when operation is delayed, or when setting the chainsaw down or when carrying the chainsaw from one location to another. Make sure all moving parts come to a complete stop.
- Carry the chainsaw by the front handle with the muffler positioned away from the body and the guide bar positioned to the rear. Cover the guide bar and saw chain with the scabbard when carrying the chainsaw.
- If you strike or become entangled with a foreign object, stop the chainsaw immediately and check for damage. Do not operate the chainsaw before repairing damage. Do not operate the chainsaw with loose or damaged parts.
- Use only original equipment manufacturer (OEM) replacement parts and accessories for this chainsaw. These are available from Champion or other qualified service dealer. Use of any other parts or accessories could lead to serious injury to the user, or damage to the chainsaw, and void the warranty.
- Keep the chainsaw clean. Carefully remove vegetation and other debris that could block moving parts.
- To reduce fire hazard, replace a faulty muffler and spark arrestor. Keep the engine and muffler free from grass, leaves, excessive grease or carbon build up.
- If the chainsaw starts to vibrate abnormally, stop the chainsaw immediately. Inspect the chainsaw for the cause of the vibration. Vibration is generally an indicator of trouble.
- Keep the work area clean. Cluttered areas invite injuries. Do not start cutting until the work area is clear and free from obstructions. Make sure there is secure footing and a planned retreat path from falling trees or branches.
- Do not cut near electrical cables or power lines. Keep at least 50 ft. (15 m) away from all power lines.
- For safer, more effective performance, make sure the guide bar and chain are properly cleaned, lubricated, tightened and sharpened. Check the guide bar and chain at frequent intervals for proper adjustment.
- When cutting a limb that is under tension, use extreme caution. When the tension is released, the limb could spring back and strike the operator, causing severe injury or death.
- Use extreme caution when cutting small-sized brush and saplings, as slender material may catch the saw chain and be whipped toward the operator or pull the operator off balance.
- This saw is classified by UL as a Class 1C saw in accordance with CSA Z62.1-03. It is intended for infrequent use by homeowners, cottagers and campers, and for general applications such as clearing, pruning, cutting firewood, etc. It is not intended for prolonged use. If the intended use involves prolonged periods of operation, this may cause circulatory problems in the user's hands due to vibration.
- Do not operate the chainsaw in a tree or on a ladder unless specifically trained to do so.
- Never remove, modify or make inoperative any safety device furnished with the chainsaw.
- Do not use the chainsaw in the presence of flammable liquids or gases.
- Do not attempt operations beyond the operator's capacity or experience.
- Do not operate a chainsaw that is damaged, improperly adjusted or not completely and securely assembled. Make sure moving parts stop when the throttle control trigger is released or the chainsaw is turned off. Do not use the chainsaw if it does not turn on and off properly. Have defective parts replaced by Champion or other qualified service dealer.

Kickback Safety

⚠ WARNING

Kickback may occur when the nose or tip of the guide bar touches an object, or when the wood closes in and pinches the saw chain in the cut. In some cases, tip contact may cause a lightning-fast reverse action, kicking the guide bar rapidly back towards the operator. Pinching the saw chain along the top of the guide bar may push the guide bar rapidly back towards the operator. Either of these reactions may cause a loss of control over the saw, which could result in serious injury to the user. Contact with foreign objects within the wood can also induce a loss of chain saw control.

Understanding Kickback

A basic understanding of kickback can help reduce or eliminate the element of surprise and the chance of kickback-related injury. Sudden surprise contributes to accidents.

- **Rotational Kickback** can happen when the upper tip of the guide bar contacts an object while the chain is moving (Fig. A). This can cause the chain to dig into the object and momentarily stop moving. The guide bar is then kicked up and back toward the operator in a lightning-fast reverse reaction.
- **Linear Kickback** can happen when the wood on either side of a cut closes in and pinches the moving saw chain along the top of the guide bar (Fig. B). This can cause the chain to instantly stop. The chain force is then reversed, causing the saw to move in the opposite direction, sending the saw straight back toward the operator.
- **Pull-In** can happen when the moving chain on the bottom of the guide bar hits a foreign object inside the wood. This can cause the chain to suddenly stop. The saw is then pulled forward and away from the operator, which could potentially result in the loss of control of the saw.

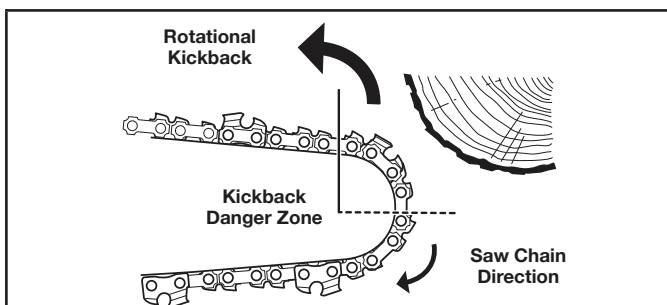

Figure A

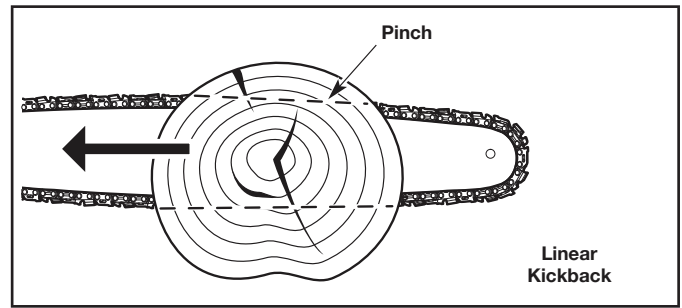

Figure B

Kickback Safety Precautions

Take the following steps to reduce the chance of accident or injury:

- Do not rely exclusively upon the safety devices built into the chainsaw.
- Do not cut above shoulder height.
- Do not over reach. Always keep proper footing and balance. Take extra care when working on steep slopes or inclines.
- Do not make cuts with the tip of the guide bar.
- Make sure the area of operation is free from obstructions. Do not let the tip of the guide bar contact any object, such as a log, branch, the ground or other obstruction.
- Always inspect the wood before cutting. Foreign objects could damage the chainsaw or cause serious personal injury. Never cut through nails, metal rods, railroad ties or pallets.
- Do not operate the chainsaw with one hand! Serious injury to the operator, helpers or bystanders may result from one-handed operation. This chainsaw is intended for two-handed use. Always grip the chainsaw firmly with both hands when the chainsaw is running. Hold the front handle with the left hand and the rear handle with the right hand. Firmly encircle the handles with the thumbs and fingers. Do not let go. A firm grip will help maintain control of the chainsaw and reduce the chance of kickback.
- Stand slightly to the left of the chainsaw to avoid being in the direct line of the saw chain.
- Never start the saw when the guide bar is inside an existing cut. Be extremely careful when re-entering a cut.
- Always begin a cut with the chainsaw running at full speed. Fully squeeze the throttle control and maintain a steady cutting speed. Slower speeds increase the chance of kickback.
- Keep the saw housing pressed firmly against the wood.
- Do not cut more than one log or branch at a time.
- Do not twist the chainsaw when removing the guide bar from a cut.
- Watch out for shifting objects (logs, branches, etc.) that might pinch or fall onto the saw chain during operation.

- Only use wedges made of wood or plastic. Do not use metal to hold a cut open.
- Follow the manufacturer's sharpening and maintenance instructions for the saw chain.
- Only use replacement bars and chains specified by the manufacturer or the equivalent. These are available from Champion or other qualified service dealer. Use of any unauthorized parts or accessories could lead to serious injury to the operator or damage to the chainsaw and will void the warranty.
- Use devices that reduce the risks associated with kickback, such as low-kickback chains, guide bar nose guards, chain brakes and low-kickback guide bars. There are no other replacement components for achieving kickback protection in accordance with CSA Z62.3.
- A low-kickback saw chain is a chain that has met the kickback performance requirements of ANSI/OPEI B175.1-2012 when tested according to the provisions specified in ANSI/OPEIB175.1-2012. A low-kickback saw chain is a chain that is also in accordance with CSA Z62.3. Do not use a replacement saw chain unless it has met these requirements for this specific model or has been designated as a low-kickback replacement saw chain in accordance with ANSI/OPEI B175.1-2012. As saw chains are sharpened, some of the low-kickback qualities are lost and extra caution should be used.
- Do not install a bow guide on this chainsaw. Bow guides have larger kickback zones, which increase the chance of kickback and serious injury. This increase is not significantly reduced by using a low-kickback saw chain. Using a bow guide on this chainsaw is extremely dangerous.
- Secure the chainsaw while transporting.
- Always use the scabbard on the guide bar and saw chain during transportation and storage.
- Always store the chainsaw and fuel in a cool, dry and well-ventilated space. Do not store fuel, or a chainsaw with fuel in the tank, indoors where fumes may reach open flames (pilot lights, etc.) or sparks (switches, electrical motors, etc.).
- Store the chainsaw in a dry place, secured or at a height to prevent unauthorized use or damage. Keep the chainsaw out of the reach of children.
- Never douse or squirt the chainsaw with water or any other liquid. Keep handles dry, clean and free from debris, oil, fuel and grease. Clean the chainsaw after each use. Refer to Cleaning and Storage. Do not use solvents or strong detergents.
- **Keep these instructions.** Refer to them often and use them to instruct other users. If you loan this chainsaw to others, also loan them these instructions.

WARNING

This spark ignition system complies with the Canadian standard ICES-002

NOTICE

For users on U.S. Forest Land and in the states of California, Maine, Oregon and Washington. All U.S. Forest Land and the state of California (Public Resources Codes 4442 and 4443), Oregon and Washington require, by law that certain internal combustion engines operated on forest brush and/or grass-covered areas be equipped with a spark arrestor, maintained in effective working order, or the engine be constructed, equipped and maintained for the prevention of fire. Check with your state or local authorities for regulations pertaining to these requirements. Failure to follow these requirements could subject you to liability or a fine. This chainsaw is factory equipped with a spark arrestor. Replacement requires a Muffler Assembly, installed at a Champion Parts & Repair Service Center.

Other Safety Warnings

WARNING

- Follow all maintenance instructions in this manual.
- All service, other than the maintenance procedures described in this manual, should be performed by a Champion qualified service dealer.
- Do not use the chainsaw if it is not working correctly, has been dropped, damaged, left outdoors or dropped into water. Have the chainsaw serviced by a Champion qualified service dealer.

Before inspecting, servicing, cleaning, storing, transporting or replacing any parts on the chainsaw:

1. Stop the chainsaw.
2. Make sure all moving parts have stopped.
3. Allow the chainsaw to cool.
4. Disconnect the spark plug wire.

Safety Labels

These labels warn you of potential hazards that can cause serious injury. Read them carefully.

If a label comes off or becomes hard to read, contact Technical Support Team for possible replacement.

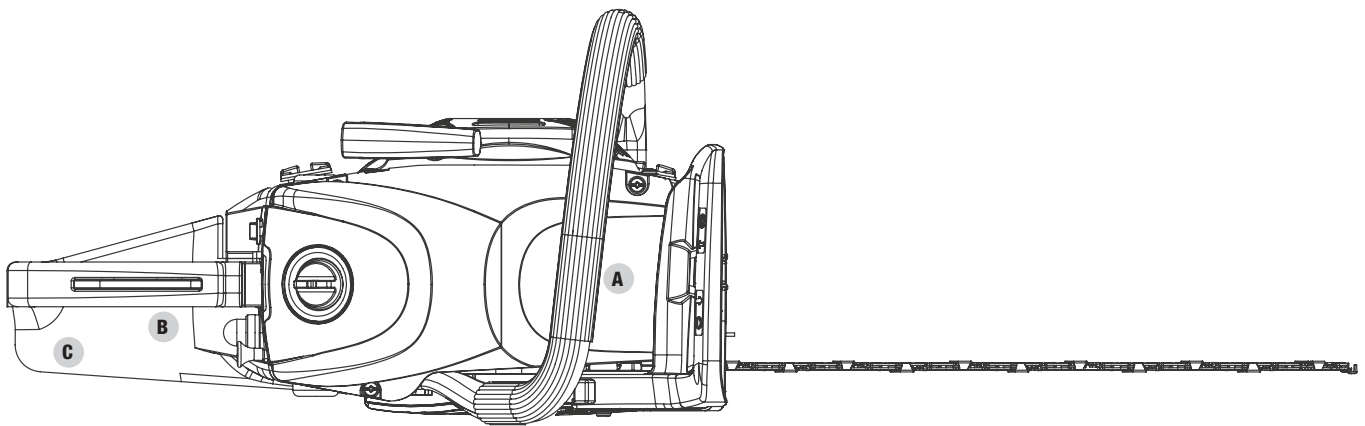





Top view

	LABEL	DESCRIPTION
A		Safety Symbols
B		Dataplate
C		Quick Start

Safety Symbols

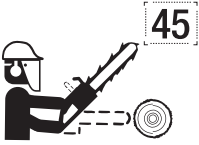
Some of the following symbols may be used on this product. Please study them and learn their meaning. Proper interpretation of these symbols will allow you to more safely operate the product.

SYMBOL	MEANING
	<p>Read Operator's Manual. To reduce the risk of injury, user must read and understand operator's manual before using this product.</p>
	<p>Eye and Ear Protection. Always wear safety goggles or safety glasses with side shields, and as necessary a full face-shield as well as full ear protection when operating this product.</p>
	<p>Kickback. Contact of the guide bar tip with any object should be avoided. Tip contact may cause the guide bar to move suddenly upward and backward, which may cause serious injury.</p>
	<p>CKA. Computed kickback angle (CKA) listed represents angle of kickback your bar and chain will have when tested in accordance with CSA (Canadian Standards Association) and ANSI standards. The bar and chain combination meet kickback requirements of CSA Standards Z62.1, Z62.3, & ANSI/OPEI B175.1 when used as shown in Specifications. Use of bar and chain combinations other than those listed is not recommended and may not meet the CKA requirements per standard.</p>
	<p>Use Both Hands. Always use both hands while operating the chainsaw. Never use only one hand to operate the chainsaw.</p>
	<p>Chain Direction. Make sure the saw chain faces the direction shown when installed on the guide bar. Refer to Installing the Guide Bar and Saw Chain in the Maintenance section.</p>

Quickstart Label Symbols

Some of the following symbols may be used on this product. Please study them and learn their meaning. Proper interpretation of these symbols will allow you to more safely operate the product.



Starting the Engine

1. Make sure chain brake is engaged.
2. Push the purge bulb at least 10-20 times, or until bulb is full of fuel.
3. Pull the choke knob out until a “click” is heard.
4. Pull the starter rope rapidly 1-4 times or until the engine pops.
5. Push the choke knob in.
6. Pull the starter rope rapidly 1-4 times to start the engine. If the engine does not start, repeat steps 3-6.
7. When engine starts, ensure the choke knob is pushed in and press and hold the throttle lockout and lightly squeeze the throttle to idle the engine.
8. Allow the engine to warm up for 30-60 seconds.
9. Carefully disengage the chain brake.

CONTROLS AND FEATURES

Read this operator's manual before operating your chainsaw. Familiarize yourself with the location and function of the controls and features. Save this manual for future reference.

Chainsaw

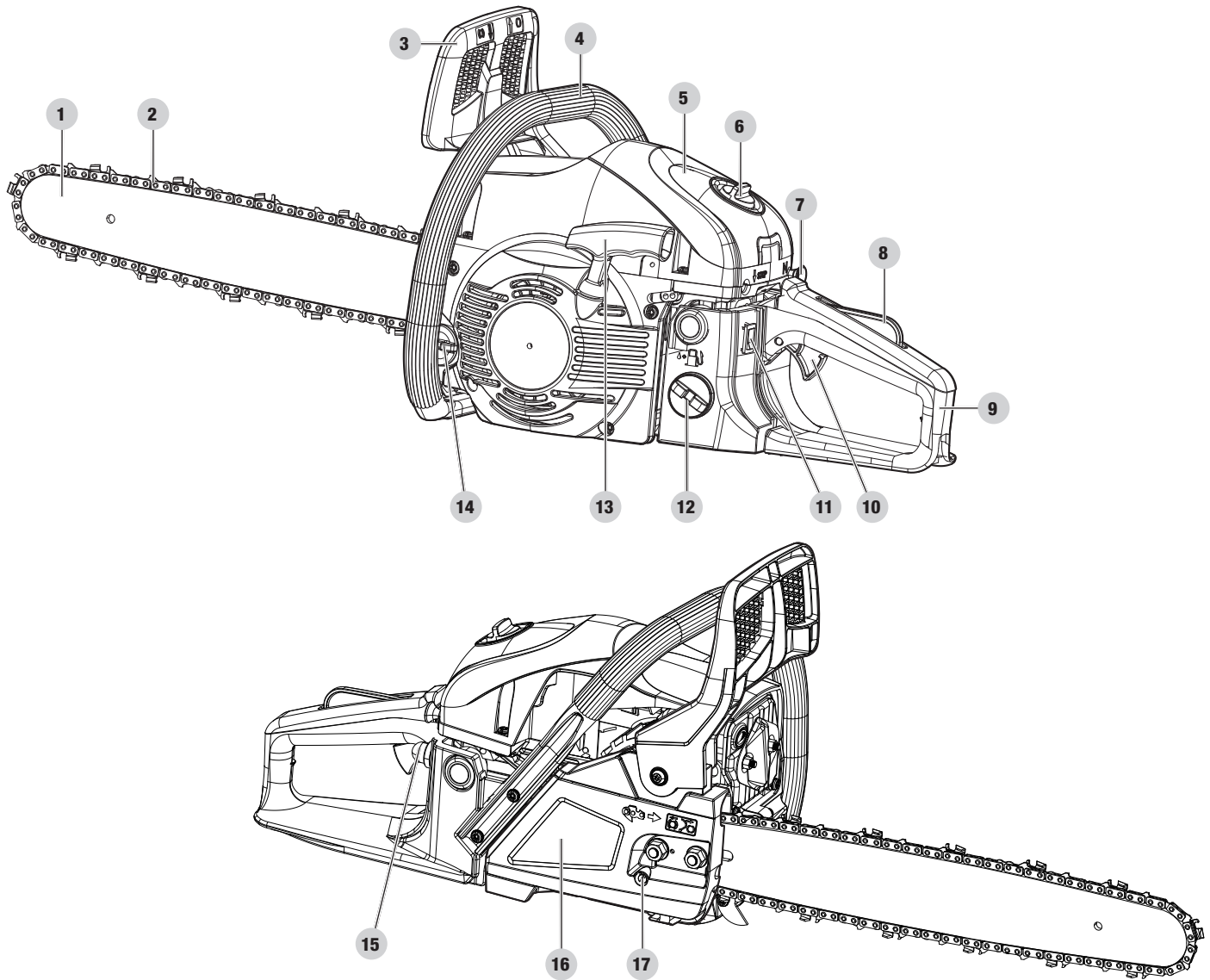

- | | |
|---|----------------------------|
| 1. Guide Bar | 10. Throttle Trigger |
| 2. Saw Chain | 11. Engine Switch |
| 3. Front Hand Guard and Chain Brake Lever | 12. Fuel Tank |
| 4. Front Handle | 13. Starter Handle |
| 5. Air Filter Cover | 14. Bar and Chain Oil Tank |
| 6. Air Cleaner Cover Knob | 15. Purge Bulb |
| 7. Choke Knob | 16. Clutch Cover |
| 8. Throttle Trigger Lockout | 17. Chain Tensioning Screw |
| 9. Rear Handle | |

Safety Features

1. **Low-Kickback Saw Chain** – significantly reduces the chance of kickback and the intensity of kickback, due to specially designed depth gauges and guard links.
2. **Spark Arrester Screen** – retains carbon and other flammable particles over 0.023 inches (0.6 mm) in size from the engine exhaust flow. Compliance with local, state and federal laws and/or regulations governing the use of a spark arrester screen is the user's responsibility. Refer to spark arrester note in the safety section for additional information.
3. **Chain Brake Lever / Front Hand Guard** – helps protect the operator's left hand if it slips off the front handle while the chainsaw is running. The chain brake lever is also used to manually engage the chain brake.
4. **Chain Brake** – reduces the chance of injury if kickback occurs, by stopping the saw chain in milliseconds. The chain brake is designed to engage automatically in response to kickback. The chain brake can also be activated by pushing the chain brake lever forward, either intentionally or if the operator's hand strikes the lever during kickback.
5. **On/Off Switch** – immediately stops the engine when moved to the off position. The ON/OFF ignition switch automatically springs back to the ON position to be ready to start the engine for next use.
6. **Throttle Lockout** – prevents accidental acceleration of the engine. The throttle control cannot be squeezed unless the throttle lockout is depressed.
7. **Chain Catcher** – reduces the chance of injury if the saw chain breaks or derails during operation. The chain catcher is designed to intercept a whipping chain.

ASSEMBLY

Adding Bar and Chain Oil: Initial Use

This chainsaw comes from the factory with the chain oil reservoir empty. Refer to *Adding Bar and Chain Oil* instructions in the *Maintenance* section.

Adjusting the Chain Tension: Initial Use

The saw chain must be properly tensioned before attempting to start or operate the chainsaw. The saw chain may also require additional tensioning as the saw chain heats up during operation. Refer to *Adjusting the Chain Tension* instructions in the *Maintenance* section.

Testing the Chain Brake

⚠ WARNING

Always activate the chain brake slowly and deliberately. Keep the saw chain from touching anything. Do not let the chain saw tip forward.

Always test the chain brake before using the chainsaw.

1. Set the chainsaw on a flat, level surface.
2. Make sure the chain brake lever is pulled back in the disengaged position (Fig. 1).
3. Start the chainsaw. Refer to Starting Instructions in the Starting and Stopping section. Maintain a proper grip. Refer to *Holding the Chainsaw* in the *Operation* section.
4. While the chainsaw is running, squeeze the throttle control to 1/3 throttle and then engage the chain brake by pushing the chain brake lever forward with the left hand (Fig. 1). The chain should stop moving abruptly.
IF... If the chain stops moving, the chain brake is working correctly.
IF... If the chain does not stop moving, have the chainsaw serviced by Champion or other qualified service dealer.
5. Stop the engine and return the chain brake to the disengaged position. Refer to *Stopping Instructions* in the *Starting and Stopping* section.

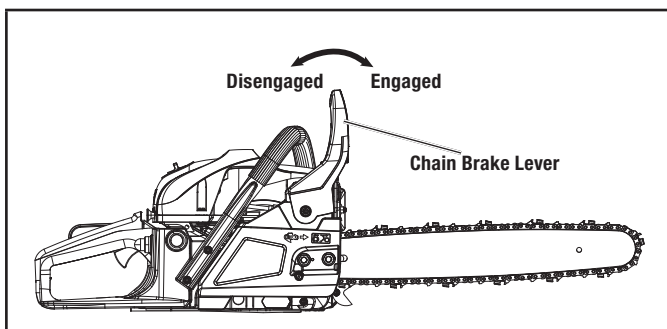

Figure 1

Oil and Fuel Mixing Instructions

The use of old and/or improperly mixed fuel is the most common cause of performance problems. Use only fresh, clean unleaded gasoline. Follow the instructions carefully for the proper gasoline/oil mixture.

The chainsaw engine works with 10% or less ethanol blended gasoline. When using ethanol-gasoline blends there are some issues worth noting:

- Ethanol-gasoline blends can absorb more water than gasoline alone.
- These ethanol blends can eventually separate, leaving water or a watery goo in the fuel tank, fuel lines, fuel filter and the carburetor. This compromised gasoline can be drawn into the carburetor and cause damage to the engine and or create potential hazards.
- Any damages or hazards caused by using ethanol blended gasoline higher than 10% by volume, improperly stored gasoline, and/or improperly formulated stabilizers, are not covered by the manufacturer's warranty.
- When a fuel stabilizer is used, confirm that it is formulated to work with ethanol-blended gasoline.
- It is recommended to drain the fuel after each use and run the engine to starvation. See Storage instructions for extended non-use.

⚠ WARNING

DO NOT use E15 fuel in this chainsaw.

Using fuel containing greater than 10% ethanol will damage this engine and void the warranty. Always use E10 or less to protect the engine's power.

Using Fuel Additives



Always use a 2-cycle oil designed for air-cooled engines and mix it with a fuel additive, such as STA-BIL Fuel Stabilizer or an equivalent. Add 0.8 oz. (23mL) of fuel additive per gallon of fuel, according to the instructions on the container. NEVER add fuel additives directly to the chainsaw's fuel tank.

Mixing the Fuel

🗨 NOTICE

For proper engine operation and maximum reliability, pay strict attention to the gasoline and oil mixing instructions on the 2-cycle oil bottle. Using improperly mixed fuel can severely damage the engine.

Thoroughly mix the proper ratio of unleaded gasoline with 2-cycle engine oil. Do not mix them directly in the chainsaw's fuel tank. Use a separate fuel can. Use a **35:1-40:1 gasoline/oil ratio**. See the table below for specific gasoline and oil mixing ratios.

MIXING RATIO - 35:1-40:1	
	
Unleaded gasoline	2-cycle oil
1 gallon U.S. (3.8 L)	3.7 fl. oz. (108.7 mL)
1 L	28.6 mL

⚠ WARNING

Gasoline is extremely flammable. Ignited vapors may explode. Always stop the engine and allow it to cool before filling the fuel tank. Do not smoke while filling the tank. Keep sparks and open flames at a distance from the area.

⚠ WARNING

Remove the fuel cap slowly to avoid injury from fuel spray. Never operate the chainsaw without the fuel cap securely in place.

⚠ WARNING

Add fuel in a clean, well ventilated outdoor area. Wipe up any spilled fuel immediately. Avoid creating a source of ignition for spilled fuel. Do not start the engine until fuel vapors dissipate.

1. Position the chainsaw with the fuel cap facing up.
2. Remove the fuel cap (Fig. 2).

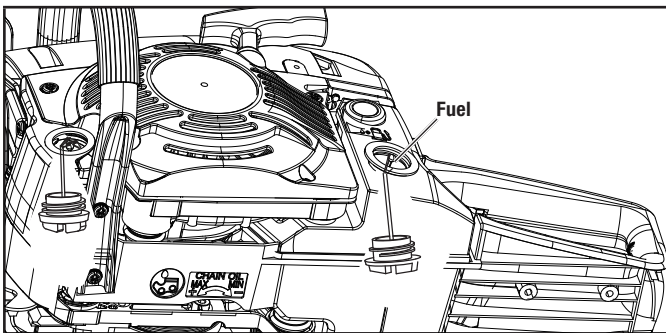

Figure 2

3. Place the fuel container spout into the fill hole on the fuel tank and slowly fill the tank to avoid overfill and spill. Fuel can expand after filling. A minimum of ¼ in. (6.4 mm) of space left in the tank is required for fuel expansion, although more than ¼ in. (6.4 mm) is recommended. Fuel can be forced out of the tank as a result of expansion if overfilled, and can affect the stable running condition of the chainsaw.

4. Wipe up any fuel that may have spilled.
5. Reinstall the fuel cap.
6. Move the chainsaw at least 50 ft. (15 m) from the fuel container and the fueling site before starting the engine.

OPERATION

Starting and Stopping

⚠ WARNING

When fueling or using your chainsaw, a fire extinguisher should be available.

⚠ WARNING

Operate this chainsaw only in a well-ventilated outdoor area. Carbon monoxide exhaust fumes can be lethal in a confined area.

⚠ WARNING

Avoid accidentally starting the chainsaw. To avoid serious injury, the operator and the chainsaw must be in a stable position when pulling the starter rope (Fig. 5).

⚠ WARNING

Never operate the chainsaw without the guide bar and saw chain properly installed. Make sure the bar-retaining nuts are tight and the guide bar cover is securely assembled. Make sure the saw chain is properly tensioned.

⚠ WARNING

The saw chain will spin after the engine starts. Keep hands and feet clear of the saw chain and do not allow the saw chain to contact any object(s).

Before Starting the Chainsaw

- A. Mix gasoline with oil. Refer to *Oil and Fuel Mixing Instructions*.
- B. Fill the fuel tank. Refer to *Fueling the Chainsaw*.
- C. Fill the chain oil reservoir with bar and chain oil. Refer to *Adding Bar and Chain Oil* in the *Maintenance* section.

Starting Instructions

1. Make sure the chain brake is engaged. Refer to *Testing the Chain Brake* in the *Assembly* section.

2. First time use, or after sitting unused for 3 or more months, slowly push the PURGE bulb all the way in and release 20 times (Fig. 4). For starting after recent use, push the PURGE bulb 10 times. If fuel cannot be seen in the purge bulb, push and release the purge bulb until fuel is visible, and then push 5 more times to purge air and vapor bubbles out of the carburetor.

NOTICE

The PURGE bulb is not used to squirt or prime gasoline into the engine's air intake. It simply pushes fuel into the carburetor pump to "purge" air bubbles and fuel vapor out of the pump. The longer the chainsaw has been left unused, the more pumps it will take to fill the bulb and purge the system. You cannot flood the engine by pushing the PURGE bulb.

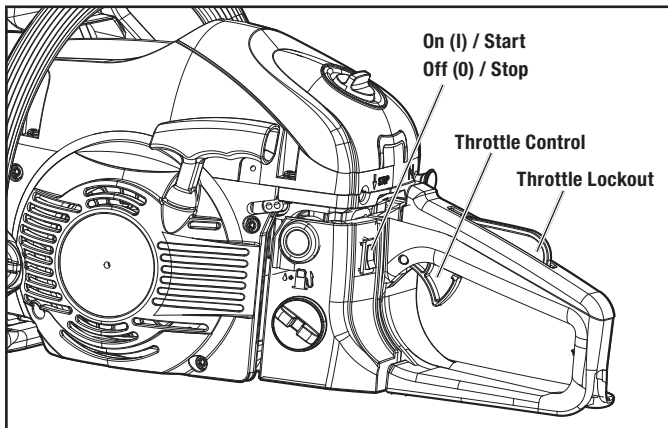

Figure 3

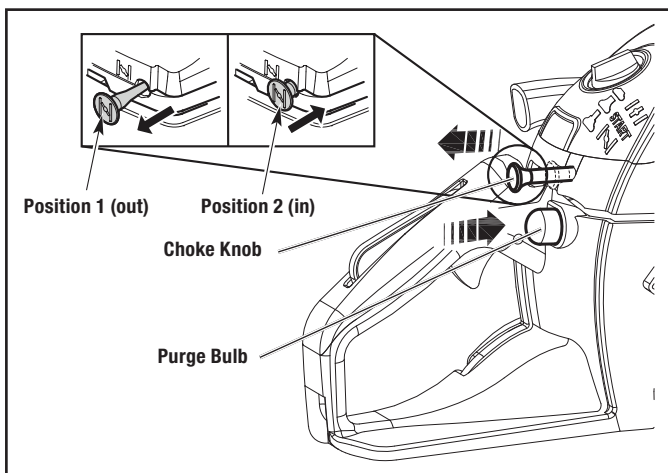

Figure 4

3. Pull the choke knob out to position 1 "CHOKE" until it locks in place and you feel and hear the click. (Fig. 4).

4. DO NOT touch the throttle control (Fig. 3). Set the chainsaw on a flat, level surface. Crouch in the starting position (Fig. 5) or bend over. Hold the front handle with the left hand. Hold the starter rope grip with the right hand. Insert the right foot into the boot loop to help hold the chainsaw firmly in place. Pull the starter rope rapidly until the engine pops or putters, or up to 4 times if you do not hear or feel the engine putter. The engine may start on this step, if not proceed to next step.

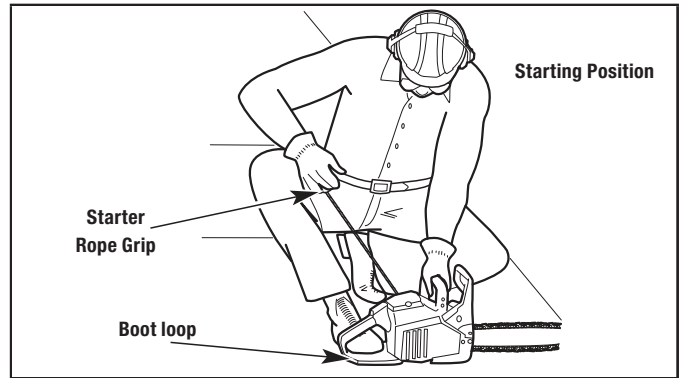

Figure 5

WARNING

Clear the area of any objects that could contact the saw chain. Always wear heavy padded gloves.

5. DO NOT touch the throttle control. After the engine pops or putters, then push the choke knob in to position 2 "RUN". In position 2, the choke is open, and the throttle is cracked open to the starting position. (Fig. 4).
6. Pull the starter rope rapidly 1-4 times to start the engine. If the engine does not start, repeat steps 3-6.
7. When engine starts, make sure choke knob is pushed in to position 2 "RUN". Press and hold the throttle lockout. Lightly squeeze and release the throttle control to release the choke automatically and idle the engine.
8. Allow the engine to warm up for 30 to 60 seconds.
9. Carefully disengage the chain brake.

WARNING

The saw chain should not move when the engine runs at idle. If it does move, refer to *Adjusting the Idle Speed* in the *Maintenance* section.

10. To reduce the chance of injury, engage the chain brake until you are ready to begin operation. When ready, disengage the chain brake. Then press the throttle lockout and squeeze the throttle control to accelerate the engine, as needed.

NOTICE

The engine is properly warmed up when it accelerates without hesitation.

IF... the engine hesitates, continue the warm-up.

IF... the engine does not start, repeat Step 2 to purge 10 times and try starting procedure again.

IF... the engine fails to start after a few attempts, pull the choke knob out to position 1 and then push the choke knob back in to position 2, so that the throttle will be set in a partially open position. Pull the starter rope with a quick and rapid motion 3 to 8 times. The engine should start. If it does not, repeat this instruction.

IF... the engine is already warm, press the purge bulb 10 times, pull the choke knob out to position 1 and then push the choke knob back in to position 2. Pull starter rope with a quick and rapid motion 3-8 times. The engine should start. If it does not, press the purge bulb 20 times until bulb is 60%-75% full of fuel, and then repeat this instruction.

WARNING

The engine may begin to creep up idle speed and intermittently turn the chain for 1-2 minutes as the engine runs out of fuel. Stop the saw and refuel to return idle speed to normal to stop chain from creeping.

WARNING

When carrying a chainsaw with engine running, always engage the chain brake.

Stopping Instructions

1. Release the throttle control and allow the engine to idle.
2. To stop the engine, depress and hold the STOP switch (Fig. 3) to the stop position.

Emergency Stopping

1. Push the chain brake lever forward to engage the chain brake. Refer to *Testing the Chain Brake* in the *Assembly* section.
2. Depress and hold the STOP switch to the stop position.

WARNING

Always check the chain tension and adjust as necessary before beginning operation. Refer to *Adjusting the Chain Tension* in the *Maintenance* section.

WARNING

Make sure the chain oil reservoir is full before operation. Check the oil level periodically so that it does not drop below half full. Make sure the chain oil adjustment screw is set appropriately. Refer to *Setting the Chain Oil Adjustment Screw* in the *Maintenance* section. The saw chain must be continuously coated with oil to function properly.

WARNING

Always wear appropriate eye, hearing, hand, foot and body protection to reduce the risk of injury when operating this chainsaw. Wear head protection. Use a full face shield. Refer to the *Safety* section for appropriate safety equipment information.

Tips for Best Results

- Follow all safety instructions. Refer to the *Safety* section.
- Only cut wood and materials made of wood. Do not attempt to cut sheet metal, plastics, masonry or any other non-wood materials.
- Practice cutting a few small logs before beginning a major cutting operation.
- Do not attempt to cut trees or logs with diameters larger than 32 in. (81.3cm).

Preparing the Work Area**WARNING**

When fueling or using your chainsaw, a fire extinguisher should be available.

- Clear the area of children, bystanders and pets; keep them outside a 50 ft. (15 m) radius, at a minimum. Even then, they are still at risk from thrown objects. Encourage bystanders to wear eye protection. If you are approached, stop the chainsaw immediately. When felling, the safe distance is at least twice the height of the tallest tree in the work area. When bucking, keep workers at least 15 feet (4.6 m) apart.
- Keep the work area clean. Cluttered areas invite injuries. Do not start cutting until the work area is clear and free from obstructions. Make sure there is secure footing and a planned retreat path from falling trees or branches.
- Do not cut near electrical cables or power lines. Keep at least 50 feet (15 m) away from all power lines.
- Use the chainsaw only in daylight or good artificial light.

Holding the Chainsaw

⚠ WARNING

When carrying a chainsaw with engine running, always engage the chain brake.

⚠ WARNING

Always hold the front handle with the left hand and the rear handle with the right hand. Always keep all body parts to the left of the chain line.

- Firmly encircle the handles with the thumbs and fingers (Fig. 6). This will help reduce the chance of losing control of the chainsaw if kickback occurs. Any grip with thumbs and fingers on the same side of the handles is dangerous.
- Always grip the chainsaw firmly with both hands when the chainsaw is running.
- Hold the front handle with the left hand. Keep the left arm straight to help withstand potential kickback.
- Hold the rear handle with the right hand. Keep the right arm slightly bent.
- Use these hand placements whether the operator is left-handed or right-handed. This will help keep the operator slightly to the left of the chainsaw and out of the direct line of the chain saw if kickback occurs (Fig. 7 and Fig. 8).
- Stand in a stable position with feet apart and firmly planted.
- Do not cut above shoulder height. Do not over reach.

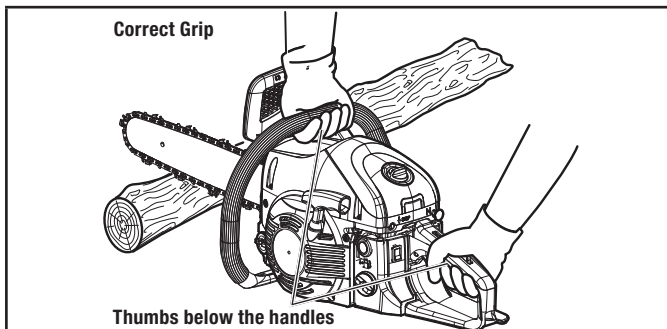

Figure 6

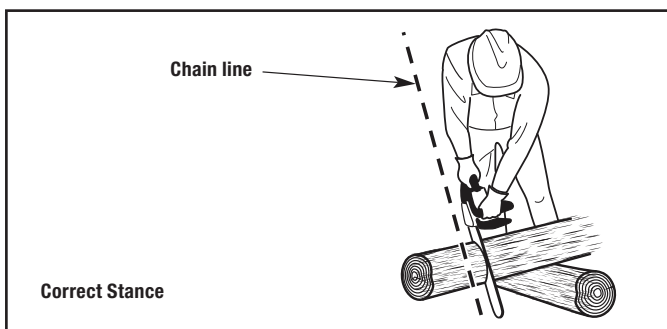

Figure 7

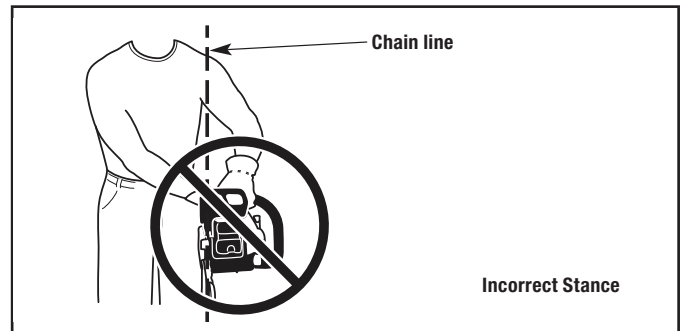

Figure 8

Wedges and Recommended Tools

- **WEDGES:** Make sure to always have plastic felling wedges on your person to use when felling trees and bucking fallen logs. OSHA requires operators of chainsaws to always have felling wedges on their person to be able to quickly react if cut begins to close on chain and to help guide tree in desired fall direction. Use the felling wedges to keep the cut open to prevent the chain from being pinched in the cut. Pinching the chain in the cut can lead to the chain derailing. Save yourself the grief and hassle of pinched & derailed chains by using use plastic felling wedges.
- **AXE OR HATCHET:** Use back side of axe or hatchet to pound felling wedges into cut to prevent pinch and to direct the desired fall direction. Use cutting edge to clear cutting work area by trimming off springy branches along trunk that may be prone to spring into your face or snag into chain.
- **HELMET WITH FACE SHIELD:** Protect your head and face from contact with chain from kickback and falling branches. Face shield keeps saw dust out of your eyes.
- **EARMUFFS:** Protect your hearing.
- **PADDED GLOVES:** Protect your hands from sharp chain, wood splinters, and circulation damage from vibration exposure.
- **CHAPS:** Protect your legs and major arteries from contact with chain with multi layered chainsaw chaps. Chaps also have pockets to keep your plastic felling wedges on hand in case of emergency.
- **TIMBER JACK:** Use 1 or 2 timber jacks to easily grab and lift fallen trees and logs off the ground to put in safe position to prevent pinching chain, to prevent chain from hitting ground, and at a more comfortable cutting height.
- **FRAMING SQUARE:** Use a large 24" x 16" framing square to sight the notch fall direction to make sure the tree is aimed in desired direction.
- **FILES:** Files are required to sharpen the chain cutters: Ø 3/16" round file and file guide. Flat file. Depth gauge.
- **GREASE GUN:** Use a grease gun to lubricate the front sprocket in the bar.

Cutting Procedure Basics

1. Start the chainsaw. Refer to *Starting Instructions* in the *Starting and Stopping* section.
2. Keep your fingers off the throttle control until you are ready to make a cut.
3. Accelerate the chainsaw to full speed before cutting.
4. Press the chainsaw against the wood and maintain a firm, steady pressure through most of the cut. Do not put pressure on the chainsaw at the end of the cut.
5. Maintain a steady speed throughout the cut. Keep the chainsaw running through the entire cut.
6. Do not try to force the saw through the wood. Allow the saw chain to do the cutting. Exert only light pressure. Forcing the cut could result in damage to the chainsaw or personal injury.
7. Release the throttle control as soon as the cut is completed. Allow the saw chain to come to a complete stop. The saw chain, guide bar and engine may experience unnecessary wear if the chainsaw is run without a cutting load.

Felling: Safety

Felling is the process of cutting down a tree. Follow these safety precautions to reduce the risk of serious injury, property damage and damage to electrical lines:

- Do not fell trees with an extreme lean. Do not fell trees with rotten limbs, loose bark or hollow trunks. Have these trees pushed or dragged down with heavy equipment.
- Do not cut trees near buildings or electrical lines. Leave these operations for professionals. If a felled tree does contact an electrical line, notify the utility company immediately.
- Check the tree for damaged or dead branches that could fall and cause serious injury.
- Remove dirt, stones, loose bark, nails, wire and other obstructions from the portion of the tree that will be cut.
- When bucking and felling operations are performed by two or more persons in the same general area, they should be separated from each other by a distance of at least twice the height of the tree to be felled.
- Consider the force and direction of the wind. Consider the lean and balance of the tree. Consider the location of large branches. All of these factors influence the direction that the tree will fall. Do not try to fell a tree in a direction other than its natural fall line.
- Do not fell trees during periods of precipitation or high winds.
- Determine a safe and expedient escape route. Clear the area around the tree and make sure there are no obstructions blocking the escape route. Establish a 90° corridor of escape, approximately 135° from the line of fall (Fig. 9).

- Stay uphill from the tree; it will most likely roll or slide after it falls.

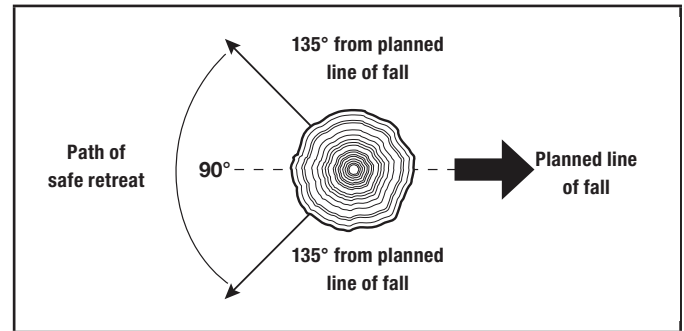

Figure 9

Felling: Procedure

Small trees, up to 6 - 7 inches (15 - 18 cm) in diameter, are usually felled in a single cut. Larger trees require a sequence of two cutting operations: a notched undercut followed by a felling back cut. It may also be necessary to remove buttress roots.

Step 1: Removing Buttress Roots

Buttress roots are large roots that extend above the ground and help support the tree. If the tree has large buttress roots that might impede the felling process, follow these steps to remove them:

1. Make a horizontal cut into the buttress root (Fig. 10). To prevent the guide bar from being pinched by the weight of the wood, always make this cut first.
2. Make a vertical cut into the buttress root (Fig. 10).

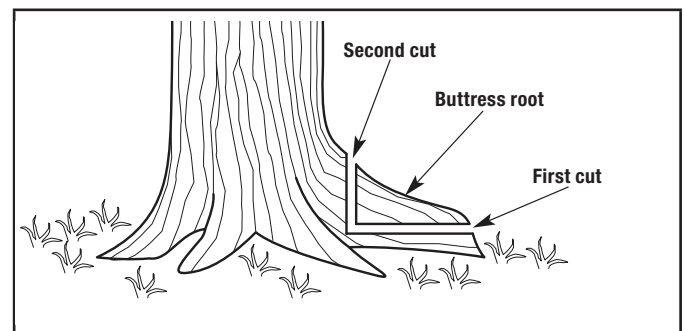

Figure 10

3. Remove the loose section from the work area.

Step 2: Making the Notched Undercut

⚠ WARNING

Never walk in front of a tree with a notched undercut.

This cut determines which direction the tree will fall. Always make this cut on the side of the tree facing the direction where the tree should fall. Make the cut at 90° to the line of fall.

1. Make a horizontal cut into the trunk of the tree (Fig. 11). The cut should be about 1/3 the diameter of the tree and close to the ground. To prevent the guide bar from being pinched by the weight of the wood, always make this cut first.
2. Make a 45° cut into the trunk of the tree, above the first cut (Fig. 11). Continue cutting until the two cuts meet.
3. Remove the loose section from the work area.

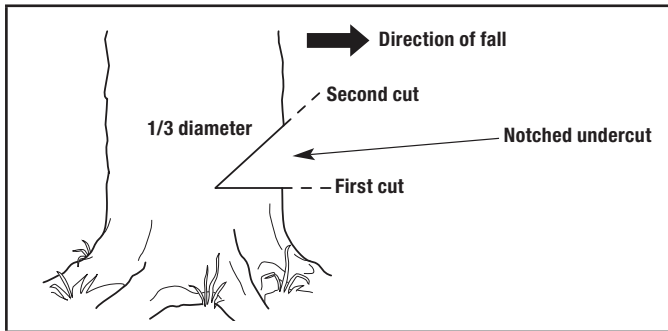

Figure 11

Step 3: Making the Felling Back Cut

⚠ WARNING

Always recheck the area for bystanders, animals and obstacles before making the felling back cut.

This cut fells the tree.

1. Make a horizontal cut into the opposite side of the tree from the notched undercut (Fig. 12). Make the cut approximately 2 inches (5 cm) above the bottom of the notched undercut (Fig. 12).
2. As the cut gets close to the notched undercut, only a thin band of wood will support the tree. This band of wood is referred to as the hinge (Fig. 12). The hinge helps control the fall of the tree. Leave approximately 2 inches (5 cm) of hinge in place. Do not cut through the hinge. Cutting through the hinge could cause the tree to fall in any direction.

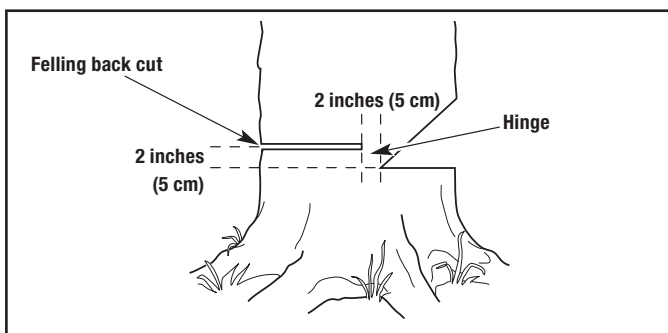

Figure 12

3. Periodically glance up during the felling back cut to see if the tree is going to fall in the correct direction. If there is a chance that the tree might not fall in the desired direction, or if the tree might rock back and bind the chain saw, remove the guide bar from the cut, stop the chainsaw and use wedges to open the cut and direct the fall (Fig. 13). Only use soft plastic or wooden wedges. Drive the wedges into the cut slowly. Once the wedges are in place and the cut is held open, either carefully reinsert the guide bar and continue the cut or slowly drive the wedges in further to push the tree over.

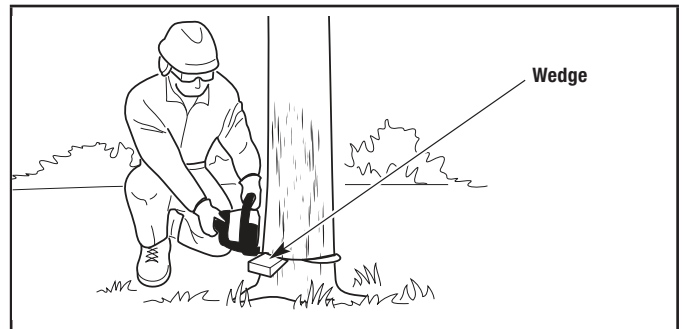

Figure 13

4. As the hinge gets smaller, the tree should begin to fall. When the tree begins to fall, remove the chain saw from the cut, stop the engine and set the chainsaw down immediately. Promptly exit the area along the retreat path, but keep watching the tree as it falls.

⚠ DANGER

If the tree starts to fall in the wrong direction and binds the chain saw, leave the chainsaw and evacuate the area immediately! Do not try to save the chain saw!

⚠ WARNING

Stay clear of spring poles when operating the chainsaw. Spring poles are branches, logs, roots or saplings that are bent under tension by other wood (Fig. 14). When the tension is released, spring poles can strike the operator, causing serious injury and potentially knocking the chain saw into the operator's body. Use extreme caution when cutting spring poles or when releasing the cause of tension.

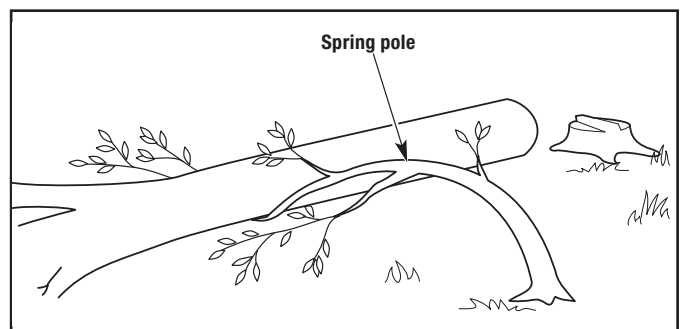

Figure 14

Limbing

Limbing is the process of removing branches from a fallen tree.

1. Leave the larger support limbs under the tree for last (Fig. 15). These will keep the tree off the ground during the limbing process.
2. Cut one limb at a time. Stand on the opposite side of the tree from the limb (Fig. 15). Keep the trunk between the operator and the chain saw. To avoid binding the chain saw, branches under tension should be cut from the bottom up.
3. Remove the cut limbs from the work area.

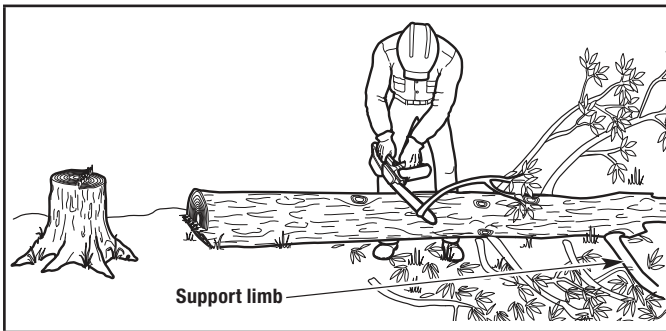

Figure 15

Bucking: Safety

Bucking is the process of cutting a fallen tree into logs of desired lengths. Follow these safety precautions to reduce the risk of serious injury:

1. Clear the area of objects or obstructions that could contact the guide bar and result in kickback.
2. When bucking on a slope, always stand on the uphill side of the fallen tree.
3. If possible, the end of the tree to be cut should be raised off of the ground. A timber jack or saw horse is ideal for this purpose. Use a timber jack to lift and support tree trunk off ground. If a timber jack or saw horse is not available, use other logs or any remaining limb stumps. Make sure the tree is firmly supported.
4. Do not let the saw chain contact the ground or saw horse.
5. Cut one log at a time. Use plastic felling wedges to prevent pinch and resulting chain derailment. Release the throttle control and allow the saw chain to come to a complete stop before moving on to the next log.
6. Keep feet and all other body parts clear of falling logs.

⚠ DANGER

Use extreme caution when cutting a fallen tree that is still attached to the root structure. When the trunk is separated from the roots, the stump has a high potential for rocking back into the hole created by the roots. This can result in serious injury or death. Never stand in the hole left by the roots. Never allow others to stand near the root structure.

Bucking: Procedure

Cutting Logs Under Stress

When logs are supported on one or both ends, the wood tends to bend during the cutting process. This can cause the chain saw to become pinched between the two sides. Pay extra attention.

1. Make the first cut approximately 1/3 the diameter of the log. Do not cut deeper than 1/3.
 - 1a. If the log is supported on one end (Fig. 16), make the first cut from below (underbucking). Refer to Underbucking.
 - 1b. If the log is supported on two ends (Fig. 17), make the first cut from above (overbucking). Refer to Overbucking.
2. Make the second cut from the opposite side until the two cuts meet. If the diameter of the wood is large enough, insert soft plastic or wooden wedges to hold the cut open and prevent pinching (Fig. 20). Take care not to touch the wedges with the saw chain.

Cutting Fully-Supported Logs

When logs are supported along the entire length, extra care should be taken to make sure the saw chain does not contact the ground or other support structure (Fig. 18).

1. Cut through the log as much as possible, without cutting into the ground or support structure. Cut from above (overbucking). Refer to Overbucking.
2. Roll the log over and finish cutting through the log from above (overbucking).

Overbucking

1. Begin cutting from above, with the bottom of the saw chain against the top of the log (Fig. 18).
2. Exert light, downward pressure. The saw will tend to pull away from the operator. Be prepared and hold the saw firmly to maintain control.

Underbucking

1. Begin cutting from below, with the top of the saw chain against the bottom of the log (Fig. 19).
2. Exert light, upward pressure. The saw will tend to push toward the operator. Be prepared and hold the saw firmly to maintain control.

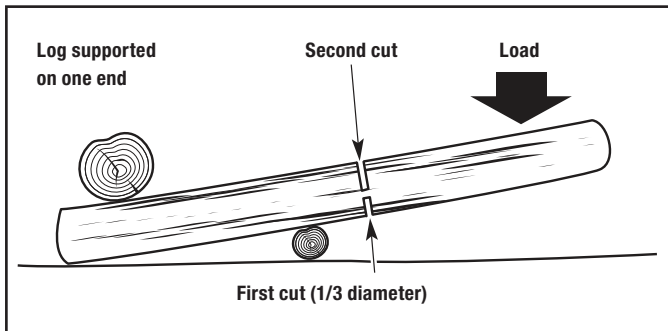

Figure 16

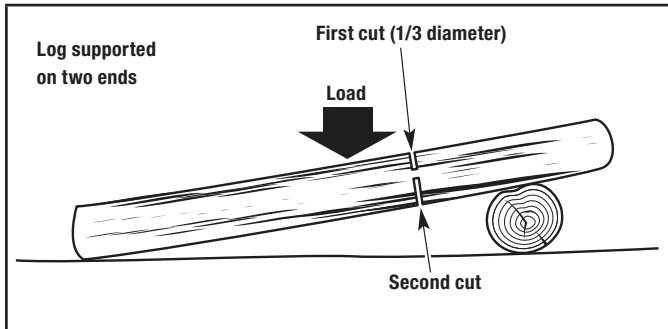

Figure 17

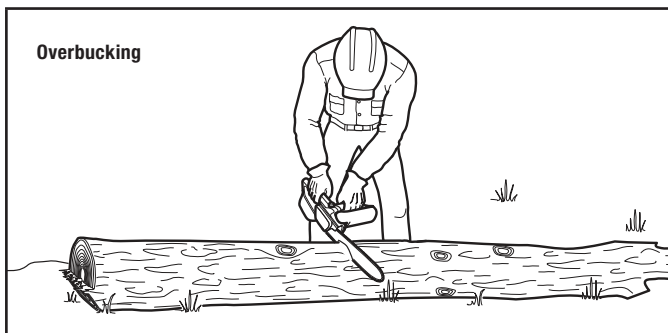

Figure 18

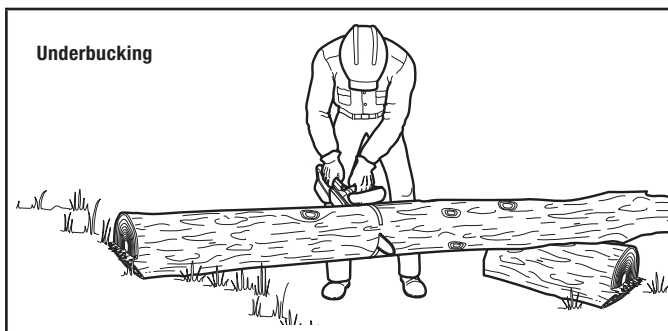

Figure 19

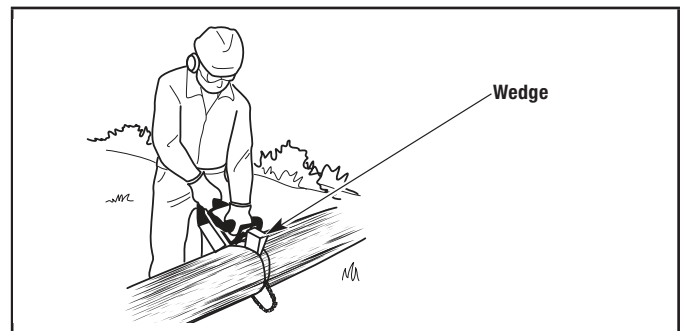

Figure 20

Pruning

⚠ WARNING

When carrying a chainsaw with engine running, always engage the chain brake.

⚠ WARNING

Do not cut above shoulder height. Use a pole saw to cut limbs above shoulder height or hire a professional. Do not operate the chainsaw in a tree or on a ladder unless specifically trained to do so.

⚠ WARNING

Falling branches can cause serious injury. Always wear appropriate head protection. Plan an escape route away from falling limbs. Do not position any body parts directly below the limb when cutting.

Pruning is the process of cutting limbs from a living tree.

1. Make the first cut approximately 6 inches (15 cm) from the tree trunk. Cut upward, from the underside of the limb. Use the top of the guide bar to make this cut. Cut a third of the way through the diameter of the limb (Fig. 21).
2. Make the second cut 2 - 4 inches (5 - 10 cm) farther out on the limb. Cut downward, from the top of the limb. Use the bottom of the guide bar to make this cut. Cut completely through the limb (Fig. 21).
3. Make the third cut as close to the tree trunk as possible. Cut upward, from the underside of the limb stub. Use the top of the guide bar to make this cut. Cut a third of the way through the diameter of the limb (Fig. 21).
4. Make the fourth cut directly above the third cut. Cut downward, from the top of the limb stub. Use the bottom of the guide bar to make this cut. Cut completely through the limb stub to meet the third cut (Fig. 21). This will remove the limb stub.

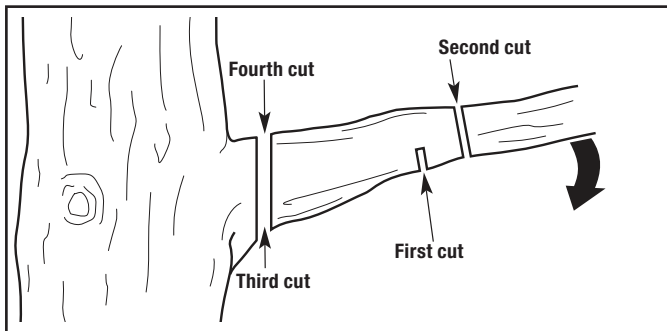

Figure 21

MAINTENANCE

⚠ WARNING

To prevent serious injury, never perform maintenance or repairs while the chainsaw is running. Always allow the chainsaw to cool before servicing or repairing the chainsaw. Disconnect the spark plug wire to prevent the chainsaw from starting accidentally.

Maintenance Schedule

Perform these required maintenance procedures at the frequency stated in the table. These procedures should also be a part of any seasonal tune-up. All service, other than the maintenance procedures described in this manual, should be performed by Champion or other qualified service dealer.

⚠ WARNING

When fueling or using your chainsaw, a fire extinguisher should be available.

🗨 NOTICE

Some maintenance procedures may require special tools or skills. If you are unsure about these procedures, take the chainsaw to Champion or other qualified service dealer. Call 1-877-338-0999 for more information.

🗨 NOTICE

Maintenance, replacement, or repair of the emission control devices and system may be performed by a Champion or other qualified service dealer. Call 1-877-338-0999 for more information.

🗨 NOTICE

For Emission control devices and systems, read and understand your responsibilities for service as stated in the Emission Control Warranty Statement of this manual.

BEFORE EACH USE

- Check for loose screws, nuts or bolts (tighten as needed)
- Check for damaged or worn parts*
- Check the saw chain sharpness. Refer to *Sharpening the Saw Chain*.
- Test the chain brake*. Refer to *Testing the Chain Brake*.
- Check the chain tension (adjust as needed). Refer to *Adjusting the Chain Tension*.
- Fill the chain oil reservoir (refill frequently). Refer to *Adding Bar and Chain Oil*.
- Fill the fuel tank with fresh, properly mixed fuel. Refer to the *Oil and Fuel* section.
- Clean the air filter. Refer to *Maintaining the Air Filter*.

AFTER EACH USE

- Clean the chainsaw and inspect decals. Refer to *Cleaning in the Cleaning and Storage* section.

EVERY 10 HOURS

- Check the spark plug condition and gap. Refer to *Maintaining the Spark Plug*.
- Clean the guide bar groove and oil passages. Lubricate the sprocket tip. Refer to *Maintaining the Guide Bar*.
- Clean the cylinder fins. Refer to *Cleaning in the Cleaning and Storage* section.

*If maintenance or replacement is required, have the chainsaw serviced by Champion or other qualified service dealer.

Adding Bar and Chain Oil

⚠ WARNING

Failure to fill the chain oil reservoir will cause irreparable damage to the chainsaw and void your warranty. Make sure the chain oil reservoir is always filled. Always use bar and chain oil.

⚠ WARNING

Oil constantly flows from the chain oil reservoir to oil the saw chain. Check the chain oil level frequently so that it does not drop below half full.

The guide bar and saw chain require lubrication to minimize friction. Never starve the guide bar and chain of lubricating oil. Running the chainsaw without enough oil will decrease cutting efficiency, shorten the life of the saw chain, cause rapid dulling of the saw chain and excessive wear to the guide bar from overheating.

An insufficient amount of lubricating oil is evidenced by smoke, guide bar discoloration or pitch build-up. Only use bar and chain oil that is formulated to perform over a wide range of temperatures with no diluting required in the chain oil reservoir. Do not use motor oil or any other petroleum-based oil. Do not use dirty, used or contaminated oil. Damage may occur to the guide bar or saw chain. Dispose of old oil according to federal, state and local regulations.

1. Set the chainsaw on a flat, level surface.
2. To prevent debris from entering the chain oil reservoir, use a damp cloth to clean the chain oil reservoir cap and surrounding area.
3. Unscrew the chain oil reservoir cap (Fig. 22).
4. Carefully pour the oil into the chain oil reservoir. DO NOT overfill.
5. Reinstall the chain oil reservoir cap.
6. Wipe up any oil that may have spilled.

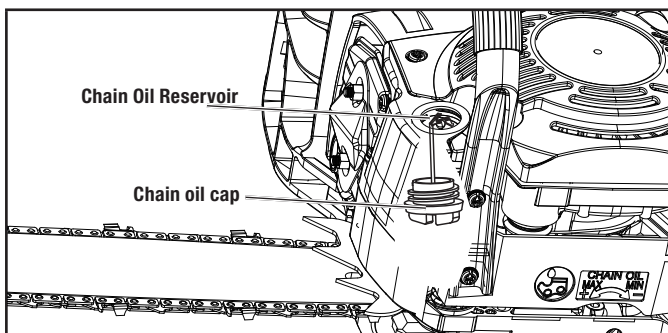

Figure 22

Adjusting the Bar And Chain Oil Flow

Bar and chain oil will slowly flow from the chain oil reservoir onto the chain. Approximately one tank of bar and chain oil is used for every tank of fuel.

- To increase the oil flow, turn the automatic oiler adjustment screw counter clockwise with a flat-head screwdriver (Fig. 23).
- To decrease the oil flow, turn the automatic oiler adjustment screw clockwise with a flat-head screwdriver (Fig. 23).

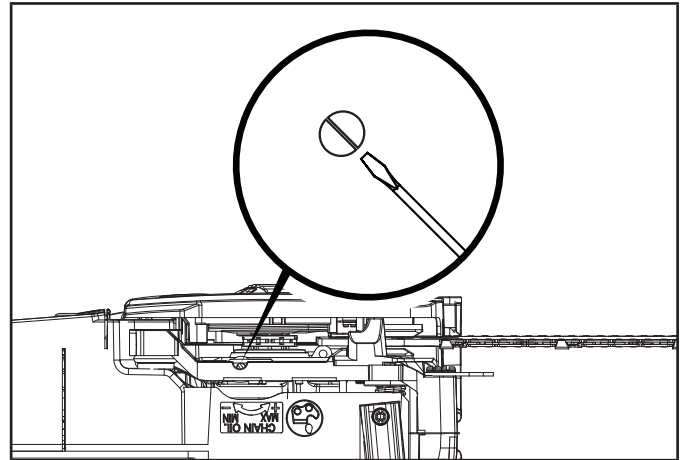

Figure 23

Adjusting the Chain Tension

⚠ CAUTION

The guide bar, saw chain, and saw bearings will wear more rapidly if the saw chain is not properly tensioned. Maintaining proper chain tension will improve cutting performance and prolong the life of the saw chain.

⚠ WARNING

To prevent serious injury, NEVER touch the saw chain or adjust the chain tension while the chainsaw is running.

⚠ WARNING

The saw chain is very sharp. Always wear heavy-duty protective gloves when handling or performing maintenance on the saw chain.

Check the chain tension before use and visually during operation. Adjust the chain tension whenever the flats on the saw chain hang out of the bar groove (Fig. 24).

1. Make sure the chain brake is disengaged. Refer to *Testing the Chain Brake* in the *Assembly* section.
2. On the clutch housing, loosen (counter clockwise) the two 13mm nuts (1/4 to 1/2 turn) that secure the housing to the engine assembly. The nuts need to be loosened enough to allow the bar to move. Do not loosen the nuts more than 1 full turn. You will notice that the bar will move with minimal effort (Fig. 25).
3. On the clutch housing, immediately below the two nuts, you will find the chain tensioning screw. Insert standard screwdriver into adjustment screw head slot. While holding the bar tip up, turn clockwise to tighten chain, (counter clockwise to loosen).

The desired chain tensioning depends upon temperature of the saw chain.

- Cold Chain Tension - The chain should fit snugly against the underside of the guide bar. No sagging should be visible (Fig. 26).
 - Warm Chain Tension - The steel blade expands when warm due to use. Approximately 1/16 inch (1.3 mm) of sag should be visible under the guide bar when warm (Fig. 26).
4. Wearing protective gloves, hold the guide bar tip up and move the saw chain back and forth along the guide bar (Fig. 27). Make sure the saw chain moves freely and is properly meshed with the sprocket. If the saw chain does not move easily, slowly turn the chain-tensioning screw counterclockwise to loosen the saw chain. The saw chain will not move if the chain brake is engaged.
 5. Hold the guide bar tip up and securely tighten the two 13 mm clutch housing nuts.

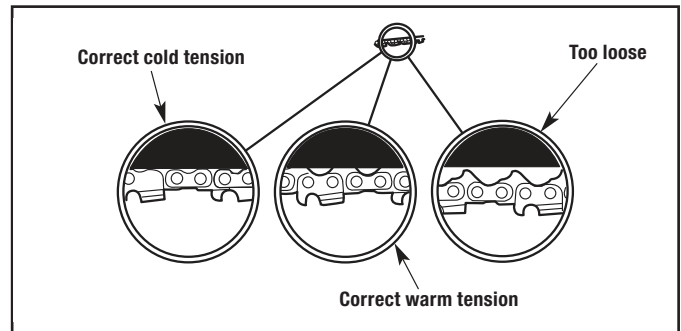

Figure 26

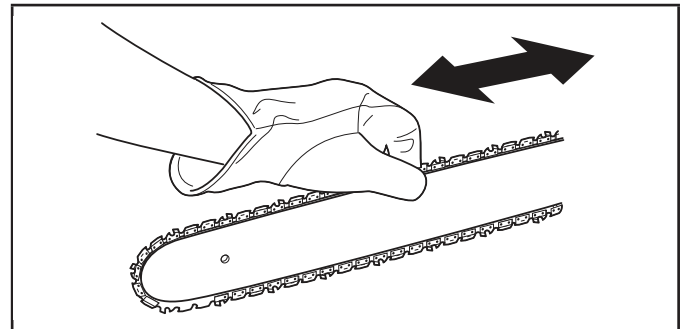

Figure 27

CAUTION

If the saw chain was tensioned while warm, it may become too tight when cooled. Loosen the chain tension after operation and check the chain tension before the next use.

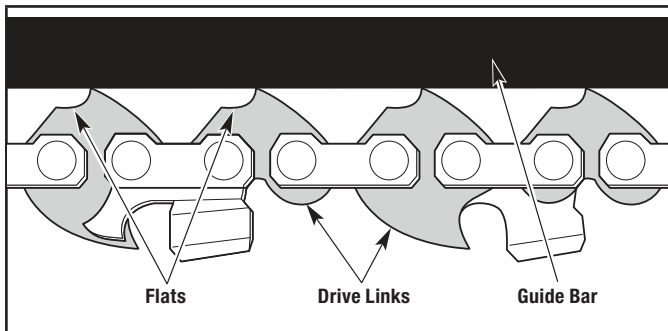

Figure 24

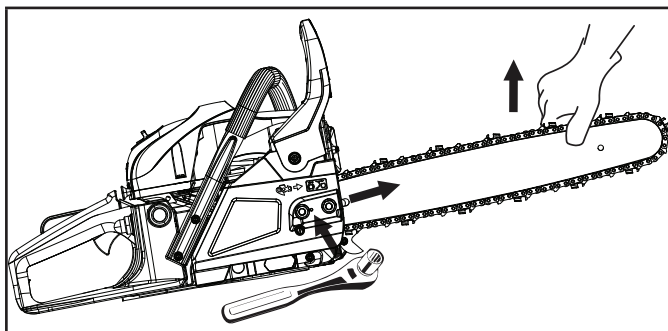

Figure 25

IMPORTANT: It is very important to maintain the proper chain tension. Rapid wear of the guide bar or the chain coming off easily can be caused by improper tension. Especially when using a new chain, take good care of it since it should expand during first use.

Removing and Installing the Guide Bar and Saw Chain

CAUTION

The guide bar, saw chain, and saw bearings will wear more rapidly if the saw chain is not properly tensioned. Maintaining proper chain tension will improve cutting performance and prolong the life of the saw chain.

WARNING

The saw chain is very sharp. Always wear heavy-duty protective gloves when handling or performing maintenance on the saw chain.

The guide bar and saw chain need to be removed when certain maintenance procedures are performed, such as when rotating the guide bar. When replacing old guide bars and saw chains with new parts, always use the manufacturer’s specified replacement parts.

Removing the Guide Bar and Saw Chain

1. Allow the chainsaw to fully cool after use. Place saw on flat and level surface.
2. On the clutch housing, remove (turning nuts counter clockwise) the two 13 mm nuts that secures the housing to the engine assembly.
3. Wearing protective gloves, hold the guide bar tip up, grasp clutch cover and wiggle it loose (Fig. 28).

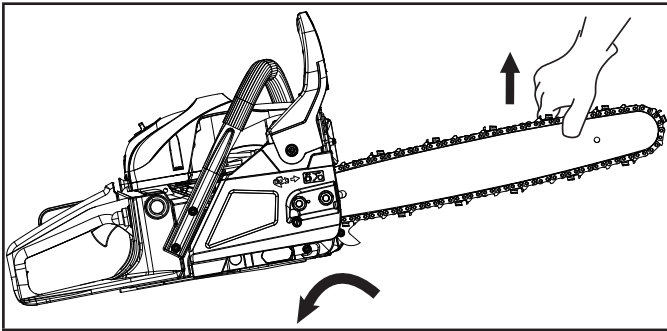

Figure 28

4. Remove housing, review for any potential damage, clean and set aside (Fig. 29).

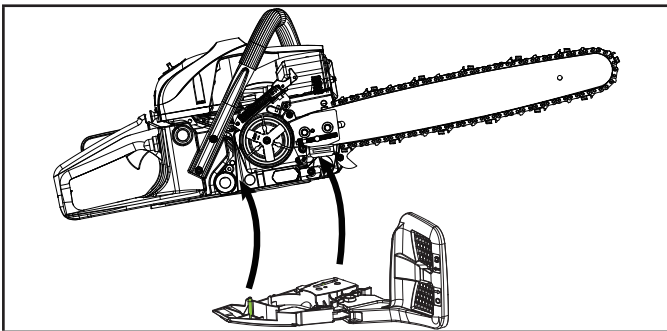

Figure 29

5. Slide bar toward engine to loosen chain (Fig. 30).

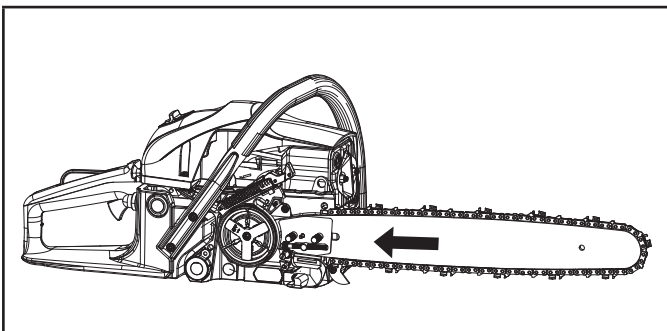

Figure 30

6. Carefully remove chain from bar, then from around gear drive clutch.
7. Remove bar from saw.
8. Clean debris, dirt, etc, from saw and bar oil ports. Inspect for damage, (replace all damaged components).

Installing the Guide Bar and Saw Chain

⚠ CAUTION

Bar and chain are sized appropriately to each saw and gear drive for chain, ONLY use approved compatible components for this saw.

1. Replace new bar where text is upright. Start by inserting bar toward gear drive clutch, rotate into position with two bolt holes protruding through slot in bar.
2. Install new blade with teeth facing correct direction. Start by wrapping blade around gear driven clutch. Position blade in alignment with gear sprocket. Then wrap blade around front of bar. Being sure align blade with teeth on front of bar as well as bar groove.
3. Turn the chain tensioning screw so the post on the cover aligns with the mating hold on the guide bar.

🗨 NOTICE

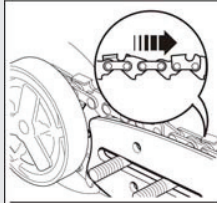

Pay attention to the correct direction of the saw chain.

4. Re-install the clutch cover, loosely install two 13mm nuts and turn (clockwise). Align brake onto clutch housing and two studs making sure the studs align with mating holes on clutch cover (Fig. 29).
5. Once the post on the clutch cover is properly aligned and inserted in the mating guide bar hole, tighten two 13mm nuts to hand tight.
6. While holding up the tip of the bar, tension saw chain by turning the tension screw clockwise (Right) until the tie straps just touch the bottom side of the bar rail (Fig. 31).

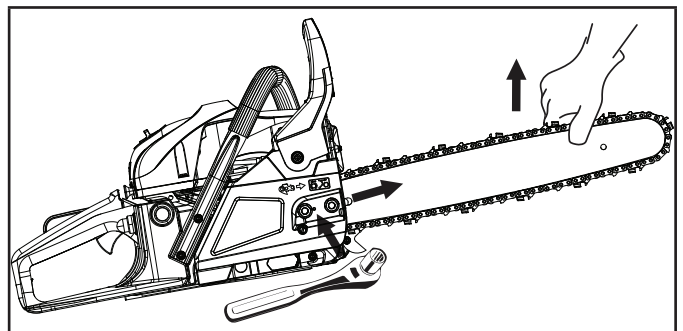

Figure 31

7. Once proper chain tension has been achieved, using a 13mm wrench or socket, fully tighten two nuts.

Maintaining the Saw Chain

For safe, efficient operation, the saw chain must be maintained properly.

The saw chain will wear with use, causing the chain to stretch. This is normal. When it is no longer possible to obtain a correct chain tension adjustment, the saw chain will need to be replaced. Refer to *Replacing the Guide Bar and Saw Chain*. Always keep the saw chain sharp. During operation, look for the following indicators of a dull saw chain:

- Wood chips are small and powdery.
- The saw chain must be forced through the wood.
- The saw chain cuts to one side. If any of these conditions exist, sharpen or replace the saw chain. Refer to *Sharpening the Saw Chain* or *Replacing the Guide Bar and Saw Chain*.

NOTICE

If you do not fully understand the sharpening procedure after reading the instructions, have the saw chain sharpened by Champion or other qualified service dealer or replace the saw chain.

Sharpening the Saw Chain

WARNING

The saw chain is very sharp. Always wear heavy-duty protective gloves when handling or performing maintenance on the saw chain.

WARNING

An improperly sharpened saw chain increases the chance of kickback. Failure to replace or properly maintain the saw chain can cause serious injury.

WARNING

A dull or improperly sharpened saw chain can cause excessive engine speed during operation, which can result in severe engine damage.

If the saw chain was damaged by contacting hard objects, such as nails or stones, or was abraded by mud or sand on the wood, have Champion or other qualified service dealer inspect for potential damage and sharpen or replace the chain and/or bar if needed.

When sharpening the saw chain, file all cutters to the specified angles and measurements. Other angles or measurements can cause excessive wear to the guide bar and saw chain, cause the chain to dull quickly and increase the chance of kickback. Fast cutting can be obtained only when all cutters are uniform.

1. Tighten the chain tension so that the saw chain is taut and does not wobble. Refer to *Adjusting the Chain Tension*.
 - 1a. Always file the saw chain at the midpoint of the guide bar.
2. Use a round file to sharpen the top plate and side plate of each cutter.
 - 2a. Use a 3/16" (4.8 mm) diameter file.
 - 2b. Keep the file level with the top plate of the cutter (Fig. 32). Do not let the file dip or rock. Use light, but firm pressure.
 - 2c. File toward the front corner of the cutter (Fig. 33). Lift the file away from the cutter at the end of the forward stroke. Only file on the forward stroke.
 - 2d. Apply a few firm strokes to each tooth. When filed correctly, the top plate will be at a 30° angle and the side plate will be at an 80° angle (Fig. 34). Using the correct file and file holder will automatically produce the correct angles.
 - 2e. File all the left-hand cutters in one direction (Fig. 33). Then move to the other side of the saw chain and file all of the right-hand cutters in the opposite direction (Fig. 33).
 - 2f. Occasionally remove filings from the file teeth with a wire brush.
3. Use a depth gauge tool (not included) to measure the depth gauge clearance (Fig. 35) of each cutter. The depth gauge clearance must be maintained at 0.025 inch (0.635 mm). The depth gauge clearance determines the depth at which the cutter enters the wood during operation and the size of the wood chips produced. Too much clearance increases the chance of kickback. Too little clearance decreases the size of the wood chips, thus decreasing the ability to cut.
 - 3a. Use a 0.025 inch (0.635 mm) depth gauge jointer and a flat file (tools not included) to lower the depth gauge to the correct clearance (Fig. 35).
 - 3b. After lowering the depth gauge, use the flat file to restore the original rounded shape to the depth gauge (Fig. 36). Take care not to damage the cutting edges or nearby links.

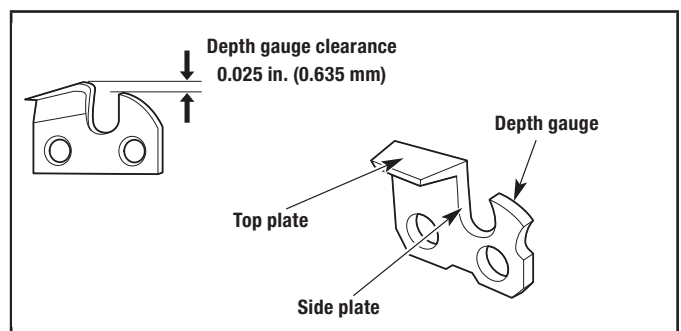

Figure 32

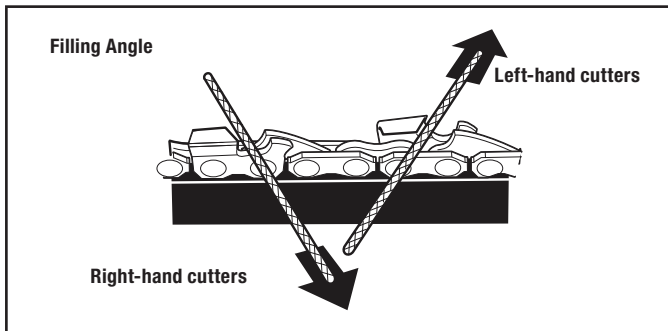

Figure 33

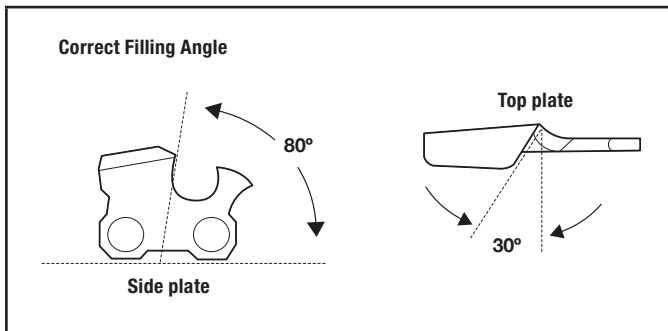

Figure 34

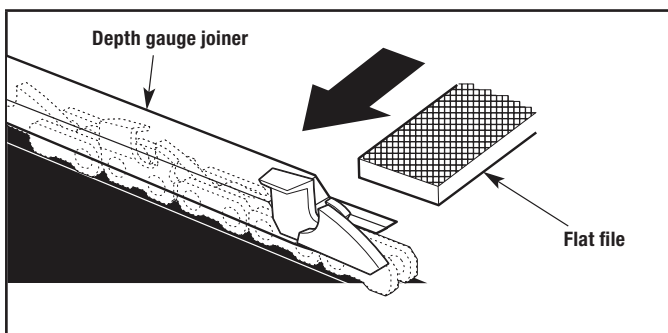

Figure 35

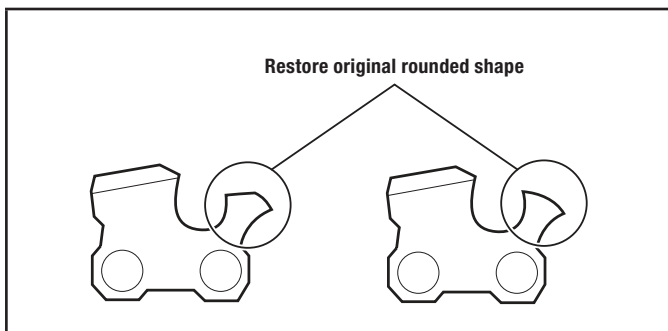

Figure 36

Maintaining the Guide Bar

1. Inspect the guide bar frequently, at regular intervals (for example, after every 5 hours of operation), to ensure even wear on the top and bottom of the guide bar. Refer to *Removing and Installing the Guide Bar and Saw Chain*.

2. Clean the guide bar groove and oil passages whenever the saw chain is removed, when the chainsaw has been used heavily or when the saw chain appears dirty. Use a screwdriver, putty knife, wire brush or similar instrument to remove debris from the guide bar groove (Fig. 37). Use a small, soft wire to remove any debris from the chain oil discharge hole (Fig. 38).

NOTICE

If the oil passages are clear, the saw chain will give off a spray of oil shortly after it begins to rotate during operation.

3. Frequently check the guide bar for damage (Fig. 39). Feathering and burring of the guide bar rails (the ridges on either side of the bar groove) is a normal process of guide bar wear. Such faults should be smoothed with a file as soon as they occur (Fig. 39). A guide bar with the following faults should be replaced:

- 3a. Wear inside the guide bar rails that permits the chain to lay sideways
- 3b. Bent guide bar
- 3c. Cracked or broken rails
- 3d. Spread rails

Refer to *Replacing the Guide Bar and Saw Chain*.

Lubricating the Guide Bar Sprocket Tip

The guide bar sprocket tip was lubricated at the factory, but requires regular lubrication. Failure to lubricate the guide bar sprocket tip will result in poor performance, damage to the chainsaw and will VOID the warranty.

NOTICE

This procedure can be performed while the guide bar and saw chain are still assembled on the chainsaw.

1. Clean the guide bar sprocket tip thoroughly with a damp cloth (Fig. 40).
2. Use a guide bar tip lube gun (not included) to inject grease into the lubrication hole (Fig. 40). Inject grease until it appears on the outer edge of the guide bar sprocket tip.
3. Rotate the saw chain by hand. Always wear heavy-duty protective gloves. Make sure the chain brake is disengaged.
4. Repeat the lubrication process until the entire guide bar sprocket tip is lubricated.

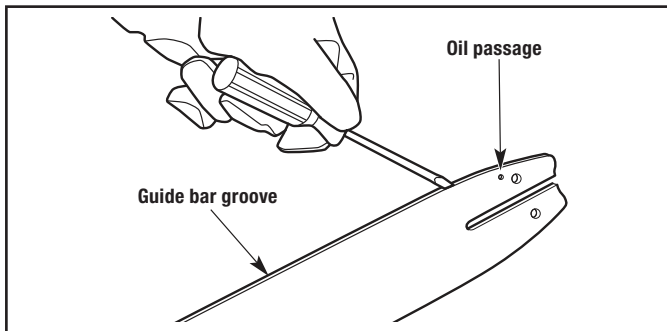

Figure 37

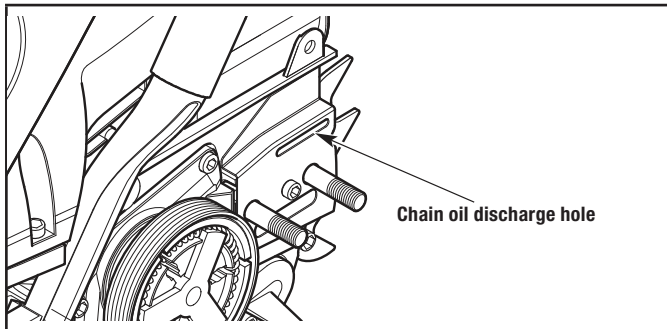

Figure 38

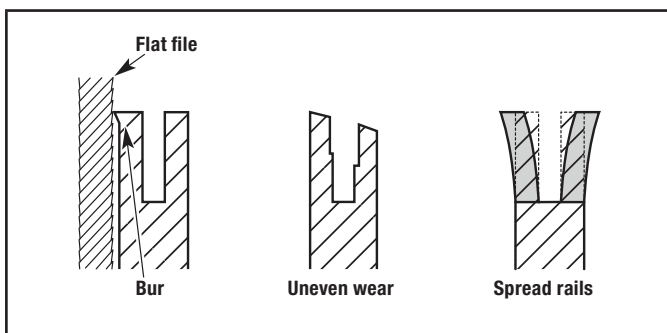

Figure 39

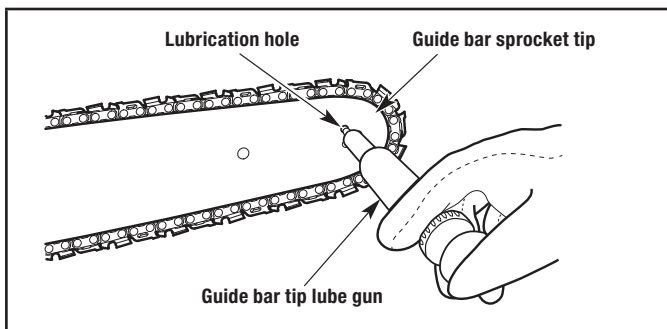

Figure 40

Replacing the Guide Bar and Saw Chain

⚠ WARNING

Always use a low-kickback saw chain, which significantly reduces the danger of kickback. Low-kickback saw chain does not completely eliminate kickback. A low-kickback or “safety chain,” should never be regarded as total protection against injury.

When replacing the guide bar and saw chain, only use the replacement parts specified by the manufacturer or their equivalents. Refer to *Replacement Parts*. Use of any unauthorized parts or accessories could lead to serious injury to the operator or damage to the chainsaw and will VOID the warranty.

Always use a replacement saw chain designated as “low-kickback” or a saw chain that meets the low-kickback performance requirements.

Maintaining the Air Filter

⚠ WARNING

To avoid serious personal injury, always stop the engine and allow it to cool before cleaning or maintaining the chainsaw.

Failure to maintain the air filter can result in poor performance or can cause permanent damage to the engine. Engine failure due to improper air filter maintenance is not covered by the product warranty.

Cleaning the Air Filter

1. Turn the knob on the air filter cover counter-clockwise to loosen the air filter cover (Fig. 41).
2. Remove the air filter cover (Fig. 41).
3. Remove the air filter (Fig. 42).
4. Wash the air filter in mild detergent and water. Rinse the air filter thoroughly and allow it to dry.
5. Reinstall the air filter onto the mounting post (Fig. 42). Make sure the opening in the air filter sits securely in the air intake (Fig. 42).
6. Place the air filter cover back onto the chainsaw. Insert the tab on the air filter cover into the slot on the chain saw housing (Fig. 41).
7. Turn the knob clockwise to tighten the air filter cover securely.

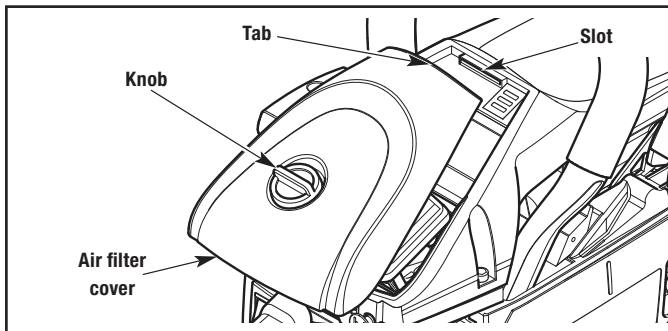

Figure 41

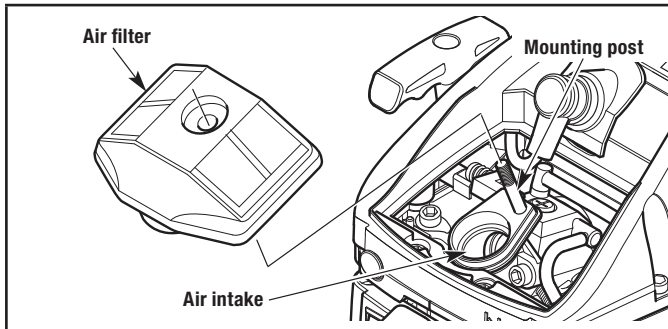

Figure 42

Adjusting the Idle Speed

⚠ WARNING

The saw chain may spin during idle speed adjustments. Wear protective gloves and clothing and observe all safety instructions to prevent serious personal injury.

If, after checking the fuel and cleaning the air filter, the engine still will not idle, adjust the idle speed screw as follows:

1. Start the engine. Refer to *Starting and Stopping*.
2. Release the throttle control and let the engine idle.
 - 2a. If the engine stops, use a small Phillips or flat-head screwdriver to turn the idle speed screw clockwise, 1/8 of a turn at a time (as needed) until the engine idles smoothly (Fig. 43).
 - 2b. If the engine idles too quickly, turn the idle speed screw counterclockwise, 1/8 of a turn at a time (as needed) to reduce the idle speed (Fig. 43).

🗨 NOTICE

The saw chain should not spin when the engine idles. If it does, reduce the idle speed until the saw chain stops moving.

Checking the fuel, cleaning the air filter, and adjusting the idle speed should solve most engine problems. If not, and any of the following conditions are true, take the chainsaw to a Champion or other qualified service dealer:

- The engine will not idle.
- The engine hesitates or stalls on acceleration.
- There is a loss of engine power.

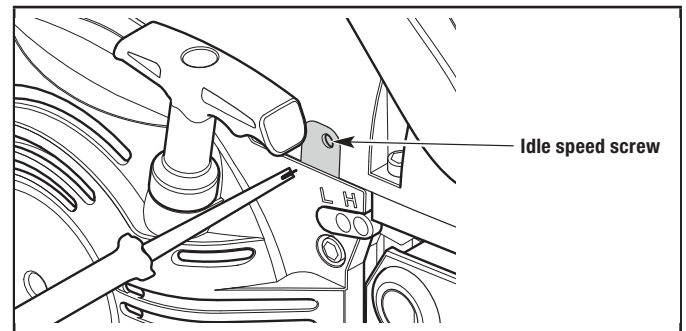

Figure 43

Maintaining the Spark Plug

1. Stop the engine and allow it to cool.
2. Turn the knob on the air filter cover counterclockwise to loosen the air filter cover (Fig. 41).
3. Remove the air filter cover (Fig. 41).
4. Grasp the spark plug boot firmly and pull it from the spark plug (Fig. 44).
5. Clean around the spark plug. Remove the spark plug from the cylinder head with the multi-purpose tool or a 5/8-inch socket wrench, turning counterclockwise.

⚠ WARNING

Do not sand blast, scrape or clean spark plug electrodes. Grit in the engine could damage the cylinder.

6. Inspect the spark plug. If the spark plug is cracked, fouled or dirty, replace it with a Champion RCJ7Y or Bosch L8RTF Spark Plug
7. Use a feeler gauge to set the air gap at 0.026 in. (0.65 mm) (Fig. 45).
8. Install the spark plug in the cylinder head. Tighten the spark plug with the multi-purpose tool or a 5/8-inch socket wrench, turning it clockwise until snug.

🗨 NOTICE

If using a torque wrench, torque to: 110-120 in.•lb. (12.4-13.5 N•m). Do not over tighten.

9. Reattach the spark plug boot.
10. Place the air filter cover back onto the chainsaw. Insert the tab on the air filter cover into the slot on the chain saw housing (Fig. 41).

- Turn the knob clockwise to tighten the air filter cover securely.

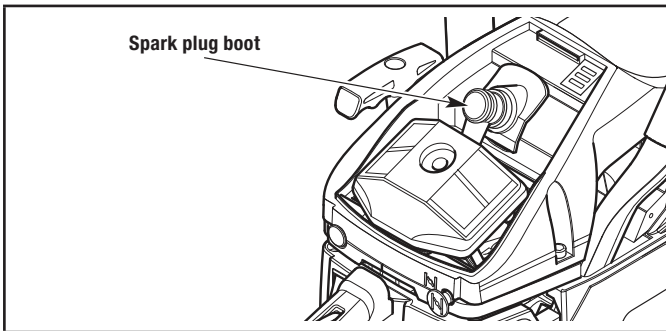

Figure 44

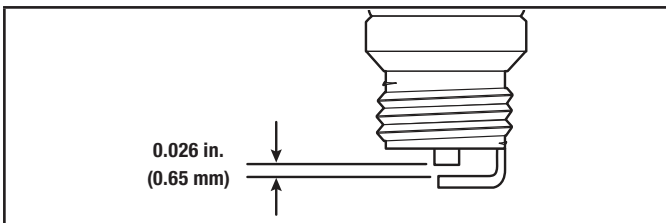

Figure 45

Cleaning

⚠ WARNING

To avoid serious personal injury, always stop the engine and allow it to cool before cleaning or maintaining the chainsaw.

- Loosen the saw chain if the chain tension was adjusted during operation. The saw chain will contract as the chainsaw cools, which could damage the chainsaw if the chain is too tight.
- Clean the chainsaw with a damp cloth. Do not douse the chainsaw with water. Do not use strong detergents. Household cleaners that contain aromatic oils such as pine and lemon, and solvents such as kerosene, can damage plastic.

🗨 NOTICE

When preparing the chainsaw for long-term storage (30 days or more), remove the guide bar and saw chain. Carefully clean the guide bar cover, guide bar mounting surface and sprocket. Use a firm non-wire brush to clean the guide bar groove. Reassemble the chainsaw.

- Wipe off any moisture with a soft cloth.

- Use compressed air, up to 40 PSI, to blow debris from the cylinder fins (Fig. 46). The cylinder fins must be cleaned on a regular basis to reduce the risk of personal injury or damage to the chainsaw as a result of fire. Always use safety goggles/glasses when using compressed air. Do not use water or other liquids to clean the cylinder fins. Use a small wire brush to remove stubborn debris.
- Lightly coat the guide bar and saw chain with a corrosion-inhibiting oil.

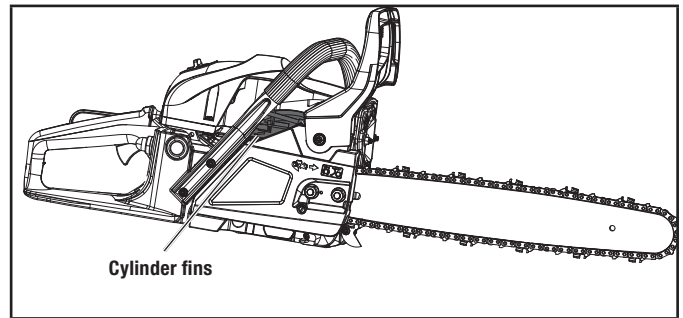

Figure 46

STORAGE

- Loosen the saw chain if the chain tension was adjusted during operation. The saw chain will contract as the chainsaw cools, which could damage the chainsaw if the chain is too tight.
- Drain the fuel and then press the purge bulb to drain the remaining fuel in the fuel lines and purge bulb.
- Allow the engine to cool before storing.
- Thoroughly clean the chainsaw and inspect it for any loose or damaged parts. Repair or replace damaged parts and tighten loose screws, nuts or bolts.
- Cover the guide bar and saw chain with the scabbard.
- Never store a fueled chainsaw where fumes may reach an open flame or spark.
- Lock up the chainsaw to prevent unauthorized use or damage.
- Store the chainsaw in a dry, well-ventilated area.
- Store the chainsaw out of the reach of children.

🗨 NOTICE

It is normal for bar and chain oil to seep from the chainsaw when not in use. Note this when storing the chainsaw.

Long-term Storage (30 days or more)

1. Remove the fuel cap, tip the chainsaw and drain the fuel into an approved container. Reinstall the fuel cap.
2. Start the chainsaw engine and allow it to run until fuel starvation and shuts off. This ensures that all fuel has been drained from the carburetor.
3. Allow the engine to cool. Remove the spark plug and put 5 drops of any high quality motor oil or 2-cycle oil into the cylinder. Pull the starter rope slowly to distribute the oil. Reinstall the spark plug.

Preparing the Chainsaw for Use after Long-term Storage

Remove the spark plug and drain all of the oil from the cylinder.

NOTICE

Do not use ethanol blended fuel that has been stored for more than 30 days. Dispose of old fuel according to federal, state and local regulations.

SPECIFICATIONS

Chainsaw Specifications

Engine Type	Air-Cooled, 2-Cycle
Displacement	45 cc (2.74 cu. in.)
Spark Plug Gap	0.026 in. (0.65 mm)
Spark Plug	Champion RCJ7Y or Bosch L8RTF
Lubrication	Bar and Chain Oil
Fuel/Oil Ratio	35:1 -40:1
Fuel Tank Capacity	18.6 fl. oz. (550 mL)
Chain Oil Reservoir Capacity	8.8 fl. oz. (260 mL)
Approximate Chainsaw Weight (without fuel or chain oil)	14.3 lbs. (6.5 kg)
Guide Bar Length	18 in. (45.7 cm)
Saw Chain Pitch	0.325 in. (8.3 mm)
Saw Chain Gauge	0.058 in. (1.5 mm)
Saw Chain Drive Links	72

*** All specifications are based on the latest product information available at the time of printing. We reserve the right to make changes at anytime without notice.*

Replacement Parts

Please contact the Customer Support Department to order replacement parts.

Part Number	Description	Brand	Pitch	Gauge	Edge
578783	Guide Bar Chain (18 in. / 45.7 cm) / Chain Set	Oregon	0.325 in (8.3 mm)	0.058 in. (1.5 mm)	3/16 in. (4.8 mm)
21BPX072X (J72)	Chain (18 in. / 45.7 cm)	Oregon	0.325 in (8.3 mm)	0.058 in. (1.5 mm)	3/16 in. (4.8 mm)
188PXBK095	Guide Bar (18 in. / 45.7 cm)	Oregon	0.325 in (8.3 mm)	0.058 in. (1.5 mm)	N/A

TROUBLESHOOTING

Problem	Cause	Solution
Engine will not start.	The fuel tank is empty	Fill the fuel tank with properly mixed fuel
	The purge bulb was not pressed enough	Press the purge bulb 10 times or until fuel is visible
	The carburetor is vapor locked	Open fuel cap to let vapor out. Press purge bulb 20 times or more until bulb is 60-75% full of fuel. Let engine cool until purge bulb can push vapor out and stay 60-75% full of fuel.
	The engine is flooded	Move the choke knob to Position 2, press the throttle lockout, squeeze the throttle control and pull the starter rope
	The fuel is old (over 30 days) and/or improperly mixed	Drain the fuel tank and add fresh, properly mixed fuel
	The spark plug is not working properly	Refer to Maintaining the Spark Plug
The engine will not idle	The air filter is dirty	Clean or replace the air filter
	The fuel is old (over 30 days) and/or improperly mixed	Drain the fuel tank and add fresh, properly mixed fuel
	The idle speed is incorrect	Adjust the idle speed
The engine will not accelerate	The fuel is old (over 30 days) and/or improperly mixed	Drain the fuel tank and add fresh, properly mixed fuel
	The air filter is dirty	Clean or replace the air filter
The engine lacks power or stalls	The fuel is old (over 30 days) and/or improperly mixed	Drain the fuel tank and add fresh, properly mixed fuel
	The air filter is dirty	Clean or replace the air filter
	The spark plug is not working properly	Refer to Maintaining the Spark Plug
The guide bar and saw chain are running hot, smoking or stuck	The saw chain tension is too tight	Adjust the saw tension
	The chain reservoir is empty	Refill the chain oil reservoir
	The guide bar groove and oil passages are dirty	Clean the guide bar and oil passages
	The automatic oiler flow is too low	Increase the oil flow
The saw chain does not rotate	The saw chain tension is too tight	Adjust the saw chain tension
	The guide bar and saw chain are assembled incorrectly	Refer to Moving and Installing the Guide Bar and Saw Chain
	The guide bar and saw chain are damaged	Inspect the guide bar and saw chain for damage. Replace them if necessary
	The drive assembly is damaged	Refer to Service information
	The chain brake is engaged	Disengage the chain brake
The saw chain rotates, but does not cut	The saw chain is dull	Sharpen or replace the saw chain
	The saw chain is on backwards	Check and correct the saw direction

For further technical support:

Technical Support Team
Toll Free 1-877-338-0999
support@championpowerequipment.com

WARRANTY*

CHAMPION POWER EQUIPMENT

2 YEAR LIMITED WARRANTY

Warranty Qualifications

To register your product for warranty and FREE lifetime call center technical support please visit:

<https://www.championpowerequipment.com/register>

To complete registration you will need to include a copy of the purchase receipt as proof of original purchase. Proof of purchase is required for warranty service. Please register within ten (10) days from date of purchase.

Repair/Replacement Warranty

Champion Power Equipment (CPE) warrants to the original consumer purchaser that each new CPE brand gasoline chainsaw is free from defects in material and workmanship and agrees to repair or replace under this warranty any defective gasoline chainsaw as follows from the original date of purchase.

2 YEARS - Parts and Labor, when used for household purposes.

30 DAYS - Parts and Labor, when used for commercial, professional, income producing purposes, or rental purposes.

This warranty is not transferable and does not cover damage or liability caused by improper handling, improper maintenance or alteration, or the use of accessories and/or attachments not specifically recommended by CPE for this chainsaw. This warranty does not cover tune-up, spark plugs, filters, starter ropes, chain sharpening, bars, chains, and other parts which wear and require replacement with reasonable use during the warranty period. This warranty does not cover pre-delivery setup, installation of guide bar and chain, and normal adjustments explained in the instruction manual such as chain tension adjustments. This warranty does not cover transportation costs. In the event you have a claim under this warranty, you must return the product to an authorized service dealer.

Should you have any unanswered questions concerning this warranty, please contact CPE Customer Service.

Limits of Implied Warranty and Consequential Damage

THIS WARRANTY GIVES YOU SPECIFIC LEGAL RIGHTS, AND YOU MAY HAVE OTHER RIGHTS WHICH VARY FROM STATE-TO-STATE/ PROVINCE-TO-PROVINCE. NO CLAIMS FOR CONSEQUENTIAL OR OTHER DAMAGES WILL BE ALLOWED, AND THERE ARE NO OTHER EXPRESS WARRANTIES EXCEPT THOSE EXPRESSLY STIPULATED HEREIN. SOME STATES/PROVINCES DO NOT ALLOW LIMITATIONS ON HOW LONG AN IMPLIED WARRANTY LASTS OR THE EXCLUSION OR LIMITATIONS OF INCIDENTAL OR CONSEQUENTIAL DAMAGES, SO THE ABOVE LIMITATIONS OR EXCLUSION MAY NOT APPLY TO YOU.

This is a limited warranty within the meaning of that term as defined in the Magnuson-Moss Act of 1975.

The policy of CPE is to continuously improve its products. Therefore, CPE reserves the right to change, modify, or discontinue models, designs, specifications, and accessories of all products at any time without notice or obligation to any purchaser.

Contact Information

Address

Champion Power Equipment, Inc.
12039 Smith Ave.
Santa Fe Springs, CA 90670 USA
www.championpowerequipment.com

Customer Service

Mon – Fri 8:30 AM – 5:00 PM (PST/PDT)
Toll Free: 1-877-338-0999
info@championpowerequipment.com
Fax no.: 1-562-236-9429

Technical Service

Mon – Fri 8:30 AM – 5:00 PM (PST/PDT)
Toll Free: 1-877-338-0999
tech@championpowerequipment.com
24/7 Tech Support: 1-562-204-1188

**CHAMPION POWER EQUIPMENT, INC. (CPE),
THE UNITED STATES ENVIRONMENTAL PROTECTION AGENCY (U.S. EPA)
EMISSION CONTROL SYSTEM WARRANTY**

Your Champion Power Equipment (CPE) engine complies with U.S. EPA emission regulations.

YOUR WARRANTY RIGHTS AND OBLIGATIONS:

The US EPA, and CPE are pleased to explain the Federal Emission Control Systems Warranty on your 2021 small off-road engine (SORE) and engine powered equipment. New equipment that use small off-road engines (SORE) must be designed, built and equipped to meet U.S. EPA regulations.

CPE must warrant the emission control system on your small off-road engine (SORE) for the period listed below, provided there has been no abuse, neglect, unapproved modification, or improper maintenance of your small off-road engine (SORE).

Your emission control system may include parts such as the carburetor, fuel tanks, fuel lines, (for liquid fuel and fuel vapors), fuel caps, valves, canisters, filters, clamps, connectors, and other associated components. Also included may be the fuel-injection system, the ignition system, catalytic converter and other emission related assemblies. Where a warrantable condition exists, CPE will repair your small off-road engine (SORE) at no cost to you including diagnosis, parts and labour.

MANUFACTURER'S EMISSION CONTROL SYSTEM WARRANTY COVERAGE:

This emission control system is warranted for two years, subject to provisions set forth below. If, during the warranty period, emission related part on your engine is defective in materials or workmanship, the part will be repaired or replaced by CPE.

OWNER WARRANTY RESPONSIBILITIES:

As the small off-road engine (SORE) owner, you are responsible for the performance of the required maintenance listed in your Owner's Manual. CPE recommends that you retain all your receipts covering maintenance on your small off-road engine (SORE), but CPE cannot deny warranty solely for the lack of receipts or for your failure to ensure the performance of all scheduled maintenance.

As the small off-road engine (SORE) owner, you should however be aware that CPE may deny you warranty coverage if your small, off-road engine or a part has failed due to abuse, neglect, improper maintenance or unapproved modifications.

You are responsible for presenting your small off-road engine (SORE) to an Authorized CPE service outlet, CPE dealer or CPE, Santa Fe Springs, CA., USA as soon as a problem exists. The warranty repairs should be completed in a reasonable amount of time, not to exceed 30 days.

If you have any questions regarding your warranty rights and responsibilities, you should contact:

Champion Power Equipment, Inc.
Customer Service
12039 Smith Ave.
Santa Fe Springs, CA 90670
1-877-338-0999
tech@championpowerequipment.com

EMISSION CONTROL SYSTEM WARRANTY

The following are specific provisions relative to your Emission Control System (ECS) Warranty Coverage.

- 1. APPLICABILITY:** This warranty shall apply to 1997 and later model year small off-road engines. The ECS Warranty Period shall begin on the date the new engine is delivered to its original, end-use purchaser and shall continue for 24 consecutive months thereafter.
- 2. GENERAL EMISSIONS WARRANTY COVERAGE**

CPE warrants to the original, end-use purchaser of the new engine or equipment and to each subsequent purchaser that each of its small off-road engines (SORE) is:

 - 2a. Designed, built and equipped to conform to U.S. EPA emissions standards for spark-ignited engines at or below 19 kilowatts.
 - 2b. Free from defects in materials and workmanship that cause the failure of a warranted part to be identical in all material respects to the part as described in the engine manufacturer's application for certification for a period of two years.
- 3. THE WARRANTY ON EMISSION-RELATED PARTS WILL BE INTERPRETED AS FOLLOWS:**
 - 3a. Any warranted part that is not scheduled for replacement as required maintenance in the Owners Manual shall be warranted for the ECS Warranty Period. If any such part fails during the ECS Warranty Period, it shall be repaired or replaced by CPE according to Subsection "d" below. Any such part repaired or replaced under the ECS Warranty shall be warranted for any remainder of the ECS Warranty Period.
 - 3b. Any warranted, emissions-related part which is scheduled only for regular inspection as specified in the Owners Manual shall be warranted for the ECS Warranty Period. A statement in such written instructions to the effect of "repair or replace as necessary", shall not reduce the ECS Warranty Period. Any such part repaired or replaced under the ECS Warranty shall be warranted for the remainder of the ECS Warranty Period.
 - 3c. Any warranted, emissions-related part which is scheduled for replacement as required maintenance in the Owner's Manual shall be warranted for the period of time prior to the first scheduled replacement point for that part. If the part fails prior to the first scheduled replacement, the part shall be repaired or replaced by CPE according to Subsection "d" below. Any such emissions-related part repaired or replaced under the ECS Warranty, shall be warranted for the remainder of the ECS Warranty Period prior to the first scheduled replacement point for such emissions-related part.
 - 3d. Repair or replacement of any warranted, emissions-related part under this ECS Warranty shall be performed at no charge to the owner at a CPE Authorized Service Outlet.
 - 3e. The owner shall not be charged for diagnostic labour which leads to the determination that a part covered by the ECS Warranty is in fact defective, provided that such diagnostic work is performed at a CPE Authorized Service Outlet.
 - 3f. CPE shall be liable for damages to other original engine components or approved modifications proximately caused by a failure under warranty of an emission-related part covered by the ECS Warranty.
 - 3g. Throughout the ECS Warranty Period, CPE shall maintain a supply of warranted emissionrelated parts sufficient to meet the expected demand for such emission-related parts.
 - 3h. Any CPE Authorized and approved emission-related replacement part may be used in the performance of any ECS Warranty maintenance or repair and will be provided without charge to the owner. Such use shall not reduce CPE's warranty obligation.
 - 3i. Unapproved add-on or modified parts may not be used to modify or repair a CPE engine. Such use voids this ECS Warranty and shall be sufficient grounds for disallowing an ECS Warranty claim. CPE shall not be liable hereunder for failures of any warranted parts of a CPE engine caused by the use of such an unapproved add-on or modified part

EMISSION-RELATED PARTS INCLUDE THE FOLLOWING: (using those portions of the list applicable to the engine)

Systems covered by this warranty	Parts Description
Fuel Metering System	Fuel regulator, carburetor and internal parts
Air Induction System	Air cleaner, intake manifold
Ignition System	Spark plug and parts, magneto ignition system
Exhaust System	Exhaust manifold, catalytic converter
Miscellaneous Parts	Tubing, fittings, seals, gaskets, and clamps associated with these listed systems.
Evaporative Emissions	Fuel tank, fuel cap, fuel line, fuel line fittings, clamps, pressure relief valves, control valves, control solenoids, electronic controls, vacuum control diaphragms, control cables, control linkages, purge valves, gaskets, vapor hoses, liquid/vapor separator, carbon canister, canister mounting brackets, carburetor purge port connector.

TO OBTAIN WARRANTY SERVICE:

You must take your CPE engine or the product on which it is installed, along with your warranty registration card or other proof of original purchase date, at your expense, to any Champion Power Equipment dealer who is authorized by Champion Power Equipment, Inc. to sell and service that CPE product during his normal business hours. Claims for repair or adjustment found to be caused solely by defects in material or workmanship will not be denied because the engine was not properly maintained and used.

If you have any questions regarding your warranty rights and responsibilities, or to obtain warranty service, please write or call Customer Service at Champion Power Equipment, Inc.

Champion Power Equipment, Inc.
12039 Smith Ave.
Santa Fe Springs, CA 90670
1-877-338-0999
Attn.: Customer Service
tech@championpowerequipment.com