



OPERATOR'S MANUAL

MODEL #200947
WALK BEHIND BLOWER



ACTIVATE YOUR WARRANTY

by registering your product:
championpowerequipment.com

SERIAL NO.



 **1-877-338-0999**

or visit championpowerequipment.com

⚠ WARNING

To reduce the risk of injury, the user must read and understand the operator's manual before using this product. If you do not understand the warnings and instructions in the operator's manual, do not use this product.

READ AND SAVE THIS MANUAL. This manual contains important safety precautions which should be read and understood before operating the product. Failure to do so could result in serious injury. This manual should remain with the product.

Specifications, descriptions and illustrations in this manual are as accurate as known at the time of publication, but are subject to change without notice.

TABLE OF CONTENTS	
Introduction	3
Safety Definitions	3
Important Safety Instructions	4
Fuel Safety	6
Safety And Dataplate Labels/Tags	7
Safety Symbols	9
Operation Symbols	11
Quickstart Label Symbols	11
Controls and Features	12
Blower	12
Engine	12
Parts Included	13
Parts Not Included	13
Assembly	14
Remove the Blower from the Shipping Carton	14
Assemble Front Wheel	14
Assemble Upper Handle	14
Assemble Throttle Control	14
Operation	15
Add Engine Oil	15
Add Fuel	16
Starting the Engine	17
Stopping the Engine	18
Blower Operation	19
Before Each Use Inspect the Blower	19
Adjust the Handle Height	19
Vertical Air Flow Adjustment	20
Forward Air Flow Attachment	20
Front Wheel Swivel	21
Operation at High Altitude	21
Maintenance	21
Cleaning the Blower	22
Engine Oil Services	22
Cleaning and Adjusting the Spark Plug(s)	23
Cleaning the Air Filter	23
Cleaning the Spark Arrestor	23
Adjusting the Governor	24
Maintenance Schedule	24
Storage	25
Short Term Engine Storage (Up to 30 Days)	25
Long Term Engine Storage (30 Days – 1 Year)	25
Specifications	26
Blower Specifications	26
Engine Specifications	26
Spark Plug Specifications	26
Valve Specifications	26
Oil Specifications	26
Fuel Specifications	26
Important Message About Temperature	26
Troubleshooting	27

 **FOR PARTS BREAKDOWN**

Search by model number at
championpowerequipment.com

INTRODUCTION

Congratulations on your purchase of a Champion Power Equipment (CPE) product. CPE designs, builds, and supports all of our products to strict specifications and guidelines. With proper product knowledge, safe use, and regular maintenance, this product should bring years of satisfying service.

Every effort has been made to ensure the accuracy and completeness of the information in this manual at the time of publication, and we reserve the right to change, alter and/or improve the product and this document at any time without prior notice.

Since CPE highly values how our products are designed, manufactured, operated and are serviced, and also highly value your safety and the safety of others, we would like you to take the time to review this product manual and other product materials thoroughly and be fully aware and knowledgeable of the assembly, operation, dangers and maintenance of the product before use. Fully familiarize yourself, and make sure others who plan on operating the product fully familiarize themselves too, with the proper safety and operation procedures before each use. Please always exercise common sense and always err on the side of caution when operating the product to ensure no accident, property damage, or injury occurs. We want you to continue to use and be satisfied with your CPE product for years to come.

When contacting CPE about parts and/or service, you will need to supply the complete model and serial numbers of your product. Transcribe the information found on your product's nameplate label to the table below

CPE TECHNICAL SUPPORT TEAM
1-877-338-0999
MODEL NUMBER
200947
SERIAL NUMBER
DATE OF PURCHASE
PURCHASE LOCATION

SAFETY DEFINITIONS

The purpose of safety symbols is to attract your attention to possible dangers. The safety symbols, and their explanations, deserve your careful attention and understanding. The safety warnings do not by themselves eliminate any danger. The instructions or warnings they give are not substitutes for proper accident prevention measures.

DANGER

DANGER indicates a hazardous situation which, if not avoided, will result in death or serious injury.

WARNING

WARNING indicates a hazardous situation which, if not avoided, could result in death or serious injury.

CAUTION

CAUTION indicates a hazardous situation which, if not avoided, could result in minor or moderate injury.

NOTICE

NOTICE indicates information considered important, but not hazard-related (e.g., messages relating to property damaged).

IMPORTANT SAFETY INSTRUCTIONS

⚠️ WARNING

Cancer and Reproductive Harm – www.P65Warnings.ca.gov

⚠️ DANGER

The blower engine exhaust contains carbon monoxide, a colorless, odorless, poison gas. Breathing carbon monoxide will cause nausea, dizziness, fainting or death.

If you start to feel dizzy or weak, get to fresh air immediately.

Operate the blower outdoors only in a well ventilated area.

DO NOT operate the blower inside any building, including garages, basements, crawlspaces and sheds, enclosure or compartment.

DO NOT allow exhaust fumes to enter a confined area through windows, doors, vents or other openings.

⚠️ DANGER

Using an engine indoors **CAN KILL YOU IN MINUTES**. Engine exhaust contains carbon monoxide. This is a poison you cannot see or smell.

NEVER use inside a home or garage, **EVEN IF** doors and windows are open.

ONLY use **OUTSIDE** and far away from windows, doors, and vents.

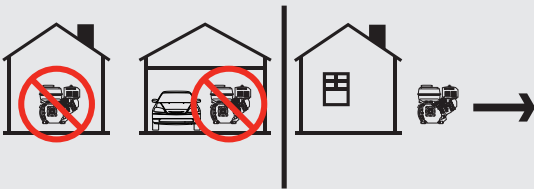

Install battery-operated carbon monoxide alarms or plug-in carbon monoxide alarms with battery back-up according to the manufacturer's instructions.

⚠️ DANGER

Rotating parts can entangle hands, feet, hair, clothing and/or accessories. Traumatic amputation or severe laceration can result.

Keep hands and feet away from rotating parts.

Tie up long hair and remove jewelry.

Operate equipment with guards in place.

DO NOT wear loose-fitting clothing, dangling drawstrings or items that could become caught.

⚠️ DANGER

DO NOT allow children or untrained individuals to use this unit.

⚠️ WARNING

Maintain a firm grip on the handle with both hands while using the blower.

⚠️ WARNING

Always wear eye protection with side shields marked to comply with ANSI Z87.1. Failure to do so could result in objects being thrown into your eyes and other possible serious injuries.

⚠️ WARNING

Always wear sound protection (ear muffs or ear plugs) to protect your hearing. Long term blower noise exposure may damage your hearing.

⚠️ WARNING

Keep all bystanders, children, and pets at least 50' (15m) away when operating the blower.

⚠️ WARNING

Wear heavy long pants, long sleeves, boots, and gloves. Do not wear loose fitting clothing, short pants, sandals, jewelry of any kind, or go barefoot.

⚠️ WARNING

To reduce the risk of injury associated with objects being drawn into rotating parts, do not wear loose clothing, scarves, neck chains, and the like.

⚠️ WARNING

Secure long hair so it is above shoulder level to prevent entanglement in any rotating parts.

⚠️ WARNING

Do not operate this unit when you are tired, ill, or under the influence of alcohol, drugs, or medication.

⚠️ WARNING

Do not operate in poor lighting.

⚠ WARNING

Wear a face filter mask in dusty conditions to reduce the risk of injury associated with the inhalation of dust.

⚠ WARNING

Check the work area before each use. Remove all objects such as rocks (where possible), broken glass, nails, wire, or string which can be thrown or become entangled in the machine.

⚠ WARNING

Keep firm footing and balance. Do not overreach. Overreaching can result in loss of balance or exposure to hot surfaces.

⚠ WARNING

The engine is equipped with a spark arrestor. Never operate the unit without a spark arrestor screen.

⚠ WARNING

Use only identical manufacturer's replacement parts and accessories.

⚠ WARNING

Inspect the unit before each use for loose fasteners, fuel leaks, etc. Replace damaged parts.

⚠ WARNING

Rotating impeller blades can cause severe injury. Stop the engine and ensure impeller blades have stopped rotating before installing/changing parts or diverters.

⚠ WARNING

Do not point the blower nozzle in the direction of people or pets when in operation.

⚠ WARNING

Spark from a removed spark plug wire can result in fire or electrical shock.

When servicing the engine:

Disconnect the spark plug wire and place it where it cannot contact the plug or any other metal object.

DO NOT check for spark with the plug removed.

Use only approved spark plug testers.

⚠ WARNING

Running engines produce heat. Severe burns can occur on contact. Combustible material can catch fire on contact.

DO NOT touch hot surfaces.

Avoid contact with hot exhaust gases.

Allow equipment to cool before touching.

Maintain at least 3 ft. (91.4 cm) of clearance on all sides to ensure adequate cooling.

Maintain at least 5 ft. (1.5 m) of clearance from combustible materials.

⚠ WARNING

Rapid retraction of the starter cord will pull hand and arm towards the engine faster than you can let go. Unintentional startup can result in entanglement, traumatic amputation or laceration. Broken bones, fractures, bruises or sprains could result.

When starting engine, pull the starter cord slowly until resistance is felt and then pull rapidly to avoid kickback.

⚠ CAUTION

Prolonged exposure to vibrations, also known as vibration white finger, through use of gasoline-powered equipment, such as this blower, could cause blood vessel or nerve damage in fingers, hands, and joints. If symptoms occur such as numbness, or loss of feeling in the fingers, hands, or joints, discontinue the use of this blower and seek medical attention.

Fuel Safety**⚠ DANGER**

GASOLINE AND GASOLINE VAPORS ARE HIGHLY FLAMMABLE AND EXPLOSIVE.

Fire or explosion can cause severe burns or death.

Gasoline and gasoline vapors:

- Gasoline is highly flammable and explosive.
- Gasoline can cause a fire or explosion if ignited.
- Gasoline is a liquid fuel but its vapors can ignite.
- Gasoline is a skin irritant and needs to be cleaned up immediately if spilled on skin or clothes.
- Gasoline has a distinctive odor, this will help detect potential leaks quickly.
- In any petroleum gas fire, flames should not be extinguished unless by doing so the fuel supply valve can be turned OFF. This is because if a fire is extinguished and a supply of fuel is not turned OFF, then an explosion hazard could be created.
- Gasoline expands or contracts with ambient temperatures. Never fill the gasoline tank to full capacity, as gasoline needs room to expand if temperatures rise.

When adding or removing gasoline:

- DO NOT light or smoke cigarettes.
- Always turn the blower off and let cool for minimum of two minutes before removing the gasoline cap. Afterwards, loosen gasoline cap to relieve pressure from the gasoline tank.
- Only fill or drain gasoline outdoors in a well-ventilated area.

- DO NOT pump gasoline directly into the blower at the gas station. Always use an approved fuel container to transfer the fuel to the gasoline tank.
- DO NOT overfill the gasoline tank.
- Always keep gasoline away from sparks, open flames, pilot lights, heat and other sources of ignition.
- Mix and store fuel in a container approved for gasoline.

When starting the blower:

- DO NOT attempt to start a damaged engine.
- Always make certain that the gasoline cap, air filter, spark plug, fuel lines and exhaust system are properly secured, connected and in place.
- Always allow spilled gasoline to evaporate fully before attempting to start the engine.
- Make certain that the blower is resting firmly on level ground.

When operating the blower:

- DO NOT move or tip the blower during operation.
- DO NOT tip the blower or allow fuel or oil to spill.

When storing the blower:

- Store away from sparks, open flames, pilot lights, heat and other sources of ignition.
- Do not store the blower or gasoline near furnaces, water heaters, or any other appliances that produce heat or have automatic ignitions.

⚠ WARNING

NEVER use a gasoline container, gasoline tank, or any other fuel item that is broken, cut, torn or damaged.

Safety And Dataplate Labels/Tags

These labels warn you of potential hazards that can cause serious injury. Read them carefully.

If a label comes off or becomes hard to read, contact Technical Support Team for possible replacement.

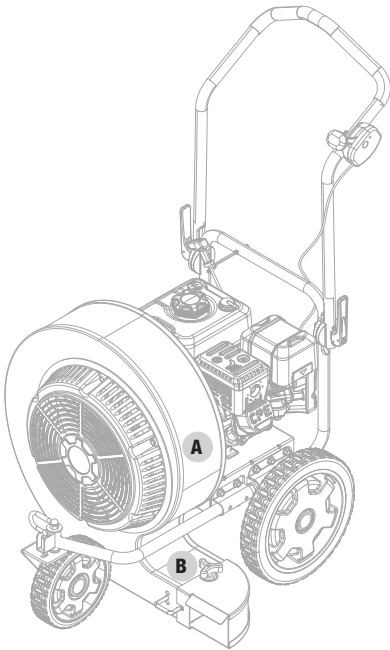

Front view

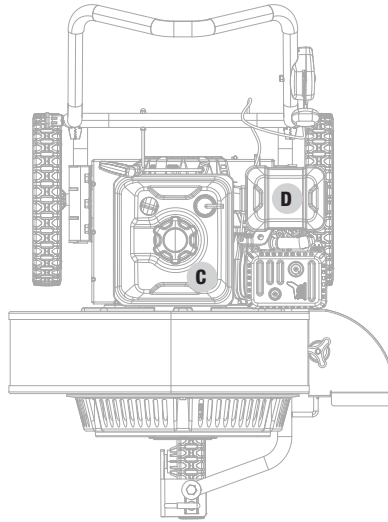



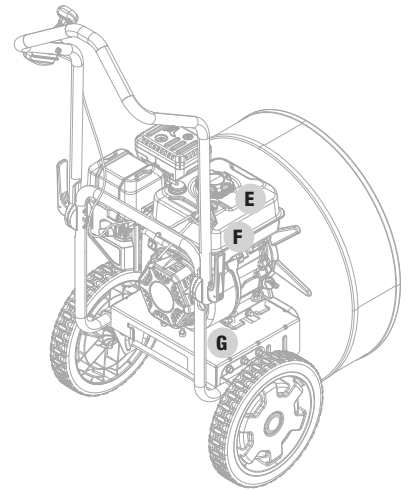

Top view





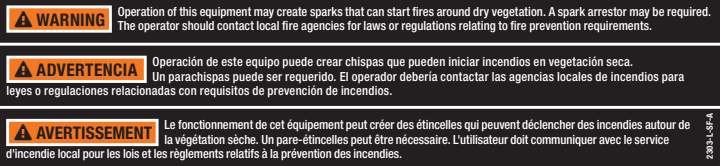





Back view





LABEL	DESCRIPTION
<p>A</p>	<p>Blower Housing Danger Label</p>
<p>B</p>	<p>Blower Discharge Danger Label</p>
<p>C</p>	<p>Fuel Requirements Label</p>

	LABEL	DESCRIPTION
D	 <p>The label features a black background with a red circle and slash over a hand touching a flame. It includes three warning sections: 'WARNING DO NOT TOUCH! Hot surface.', 'ADVERTENCIA ¡NO TOCAR! Superficie caliente.', and 'AVERTISSEMENT NE TOUCHEZ PAS! Surface chaude.' A red arrow points left. The part number '1094-LSP-8' is printed vertically on the right.</p>	Hot Surface Warning Label
E	 <p>The label is a horizontal strip with a red top border containing 'DANGER', 'PELIGRO', and 'DANGER' with triangle icons. It contains several safety icons: a person reading a manual, eye protection, foot protection, hand protection, a warning triangle, a flame, a no smoking sign, a no open flame sign, a no fire sign, and a person with a fire extinguisher. The part number '1094-LSP-4' is printed vertically on the right.</p>	Engine Danger Label
F	 <p>The label has a black background with three warning sections in different languages: 'WARNING Operation of this equipment may create sparks that can start fires around dry vegetation. A spark arrestor may be required. The operator should contact local fire agencies for laws or regulations relating to fire prevention requirements.', 'ADVERTENCIA Operación de este equipo puede crear chispas que pueden iniciar incendios en vegetación seca. Un parachispas puede ser requerido. El operador debería contactar las agencias locales de incendios para leyes o regulaciones relacionadas con requisitos de prevención de incendios.', and 'AVERTISSEMENT Le fonctionnement de cet équipement peut créer des étincelles qui peuvent déclencher des incendies autour de la végétation sèche. Un pare-étincelles peut être nécessaire. L'utilisateur doit communiquer avec le service d'incendie local pour les lois et les règlements relatifs à la prévention des incendies.' The part number '230-LSP-A' is printed vertically on the right.</p>	Spark Arrestor Warning Label
G	 <p>The label is a white rectangular plate with the following text: 'CHAMPION POWER EQUIPMENT, INC. 8215 PIONEER WAY, UNIT 101 LAS VEGAS, NV 89115 USA (U.S.A.) 702-234-9999 WWW.CHAMPIONPOWEREQUIPMENT.COM MADE IN CHINA / FABRIQUÉ EN CHINE'. It includes a barcode with the number '8 417198 03704 0', a QR code, and a registration section: 'REGISTER TO ACTIVATE YOUR WARRANTY / RÉGISTREZ-VOUS POUR ACTIVER VOTRE GARANTIE'. The part number '230-LSP-A' is printed vertically on the right.</p>	Product Data Plate Label

Safety Symbols



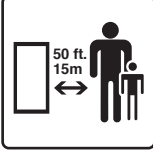
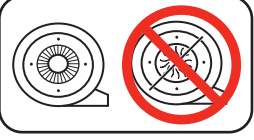

Some of the following symbols may be used on this product. Please study them and learn their meaning. Proper interpretation of these symbols will allow you to more safely operate the product.



SYMBOL	MEANING
	<p>Read Operator's Manual. To reduce the risk of injury, the user must read and understand the operator's manual before using this product. If you do not understand the warnings and instructions in the operator's manual, do not use this product.</p>
	<p>Eye and Ear Protection. Always wear eye protection with side shields marked to comply with ANSI Z87.1. Failure to do so could result in objects being thrown into your eyes and other possible serious injuries.</p> <p>Always wear sound protection (ear muffers or ear plugs) to protect your hearing. Long term blower noise exposure may damage your hearing.</p>
	<p>Footwear. Always wear safety shoes or heavy boots when operating the machine.</p>
	<p>Gloves. Always wear nonslip, heavy-duty protective gloves when operating this product.</p>
	<p>Safety Alert. Precautions that involve your safety.</p>
	<p>Risk of Fire. Fuel and its vapors are extremely flammable and explosive. Fire can cause severe burns or death. Do not add fuel while the product is operating or still hot.</p>
	<p>Open Flame alert. Fuel and its vapors are extremely flammable and explosive. Keep fuel away from smoking, open flames, sparks, pilot lights, heat, and other ignition sources.</p>
	<p>Hot Surface. To reduce the risk of injury or damage, avoid contact with any hot surface</p>

SYMBOL	MEANING
	<p>Amputation Hazard. Rotating parts can entangle hands, feet, hair, clothing and/or accessories. Traumatic amputation or severe laceration can result.</p>
	<p>Toxic Fumes. The engine exhaust from this product contains chemicals known to the state of California to cause cancer and birth defects and other reproductive harm.</p> <p>Risk of Asphyxiation. This engine emits carbon monoxide, an odorless, colorless poison gas. Breathing carbon monoxide can cause nausea, fainting or death. Use only in a well ventilated area.</p>
	<p>Thrown Objects. This machine may pick up and throw objects which can cause personal injury. Check the work area before each use. Remove all objects such as rocks (where possible), broken glass, nails, wire, or string which can be thrown or become entangled in the machine.</p>
	<p>Clearance. Keep all bystanders, children, and pets at least 50' (15m) away when operating the blower.</p>
	<p>Never run the unit without the blower fan cover installed. Use of an improperly assembled unit could result in serious personal injury.</p>
	<p>Serious Personal Injury or Property Damage. Before inspecting, cleaning, or servicing the blower, shut off the engine. Wait for all moving parts to stop, disconnect spark plug wire and move it away from the spark plug. Failure to follow these instructions could result in personal injury or damage to the blower.</p>

Operation Symbols

Some of the following symbols may be used on this product. Please study them and learn their meaning. Proper interpretation of these symbols will allow you to more safely operate the product.

SYMBOL	MEANING
	Choke/Run
	Fuel Valve: CLOSED/OPEN
	Throttle Lever FAST: forward position
	Throttle Lever SLOW: rear position

SYMBOL	MEANING
	Fuel Gauge: Full
	Fuel Gauge: Empty
	Stop

Quickstart Label Symbols

Some of the following symbols may be used on this product. Please study them and learn their meaning. Proper interpretation of these symbols will allow you to more safely operate the product.



Starting the Engine

- Check Oil Level.** Recommended oil is 10W-30. The engine can be seriously damaged without oil. Always check the oil level before using. The machine must be resting firmly on level ground when checking.
- Add gasoline with a minimum octane rating of 87 and an ethanol content of less than 10% by volume.
- Move the choke lever to **“CHOKE”** position.
- Move the throttle lever, on the handle at the user position, to the **“FAST”** position (forward).
- Move the fuel valve to **“OPEN”** position.
- Pull the starter cord slowly until resistance is felt and then pull rapidly.
- As engine warms up, move the choke to **“RUN”**.

Stopping the Engine

- Move the fuel valve to the **“CLOSED”** position.
- Press the engine switch to the **“OFF”** position.

CONTROLS AND FEATURES

Read this operator's manual before operating your blower. Familiarize yourself with the location and function of the controls and features. Save this manual for future reference.

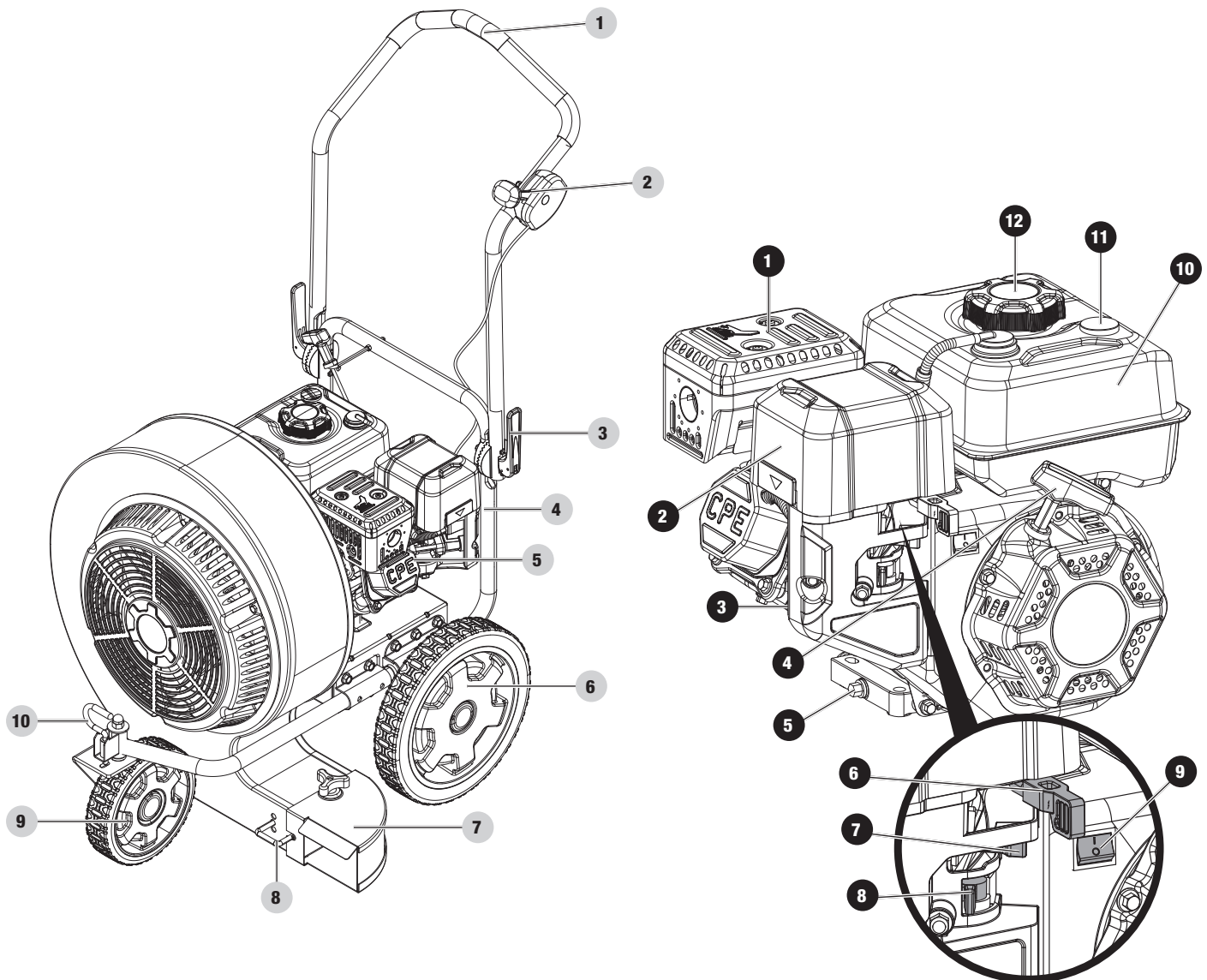



Blower

- 1. Upper Handle
- 2. Throttle/Speed Control
- 3. Handle Adjust Lever
- 4. Lower Handle
- 5. Engine
- 6. Rear Wheel
- 7. Forward Air Flow Attachment
- 8. Vertical Air Flow Adjustment
- 9. Front Wheel
- 10. Front Wheel Swivel Lock

Engine

- 1. Muffler
- 2. Air Filter
- 3. Oil Fill Cap/Dipstick
- 4. Recoil Starter
- 5. Oil Drain Bolt
- 6. Throttle
- 7. Choke
- 8. Fuel Valve
- 9. Engine OFF Switch
- 10. Fuel Tank
- 11. Fuel Gauge
- 12. Fuel Tank Cap

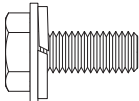
Parts Included

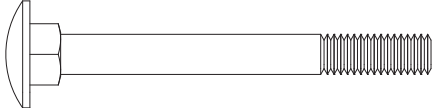
Part	Part Qty.	Hardware Needed	Hardware Qty.	Hardware Reference	Tool Needed
Front wheel	1	M8x20 Hexagon bolt	4		13mm Wrench
Upper handle	1	M8 Nylon flange lock nut	2		13mm Wrench
Throttle control	1	M6x65 carriage bolt	1		10mm Wrench
		M6 Nylon flange lock nut	1		
Forward flow air attachment	1	N/A			
Engine Oil 16.9 fl. oz (500 ml)	1	N/A			
Engine Oil Funnel	1	N/A			

Parts Not Included

- Metric Wrench or Socket Set
- Phillips Screwdriver
- Pliers

ASSEMBLY

Your blower requires some assembly. This unit ships from the factory without oil. It must be properly serviced with fuel and oil before operation. For questions regarding the assembly of your blower, call our help line at 1-877-338-0999. Please have your serial number and model number available.

Remove the Blower from the Shipping Carton

1. Set the shipping carton on a solid, flat surface.
2. Remove all contents from the carton.

Assemble Front Wheel

1. Align the 4 holes on the front wheel bracket with the 4 holes on the blower frame near the rear wheel on the left side of the frame (from the user position).
2. Thread a M8 × 20 hex bolt into each hole and, using a 13mm wrench, tighten to 15 lbf. ft. - 19 lbf. ft. (20.3 - 25.8 Nm)

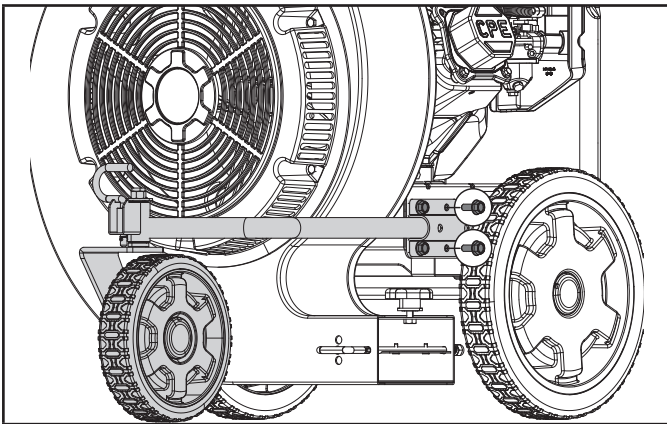

Assemble Upper Handle

1. Place the upper handle assembly down over the lower handle assembly, with the upper handle on the outside, and align the teeth of the upper handle adjuster so they seat into the teeth on the lower handle adjuster.
2. From the outside of the handle assembly, insert the threaded end of the handle adjust lever through the hole on the upper handle assembly and the hole on the lower handle assembly.
3. Thread a M8 nylon lock nut onto the threaded end of the handle adjust lever. Holding the handle adjust lever in place, use a 13mm socket or wrench to tighten the lock nut securely locking the handle in place. (see operation section for handle height adjustment).

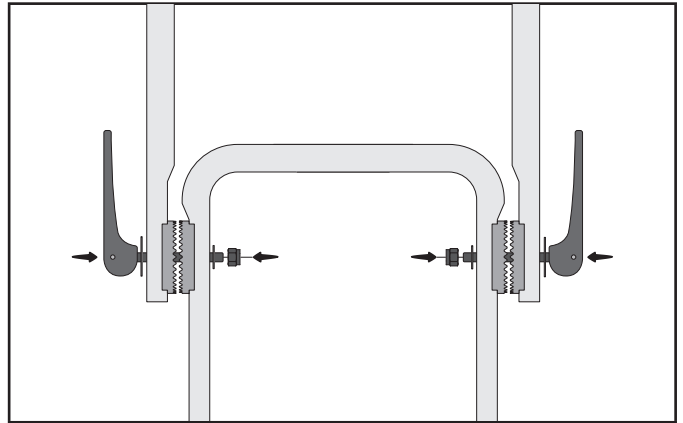

Assemble Throttle Control

1. Align the throttle control to the outside of the upper left handle (from the user position) with the groove against the handle and fast speed towards the front.
2. From the outside of the throttle control, place the M6 × 65 carriage bolt through the hole on the throttle and through the hole on the handle tube.
3. Thread the M6 nylon lock nut onto the bolt and tighten securely.

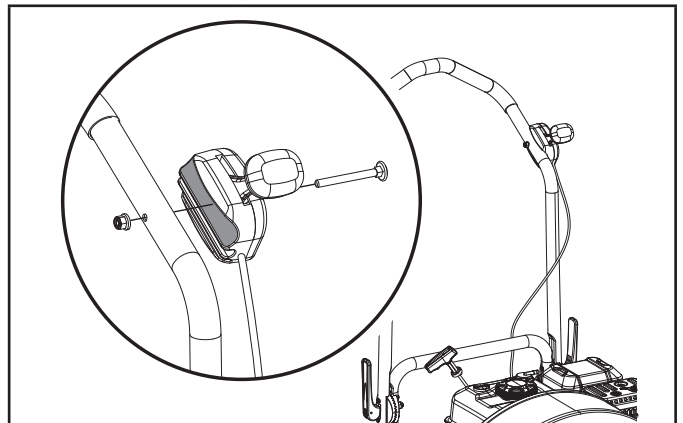

OPERATION

Add Engine Oil

CAUTION

DO NOT attempt to crank or start the engine before it has been properly filled with the recommended type and amount of oil. Damage to the engine as a result of failure to follow these instructions will void your warranty.

NOTICE

The recommended oil type is **10W-30 automotive oil**. If running engine in extreme temperatures, refer to the following chart for recommended oil type.

Recommended Engine Oil Type								
			10W-30			→		
	←		5W-30			←		10W-40
	← 5W-30 Full Synthetic →							
°F	-20	0	20	40	60	80	100	120
°C	-28.9	-17.8	-6.7	4.4	15.6	26.7	37.8	48.9
Ambient temperature								

1. Place the blower on a flat, level surface.
2. Remove oil fill cap/dipstick to add oil.
3. Using a funnel, add up to 16.9 fl. oz (500 ml) of oil (included) and replace oil fill cap/dipstick. DO NOT OVERFILL.

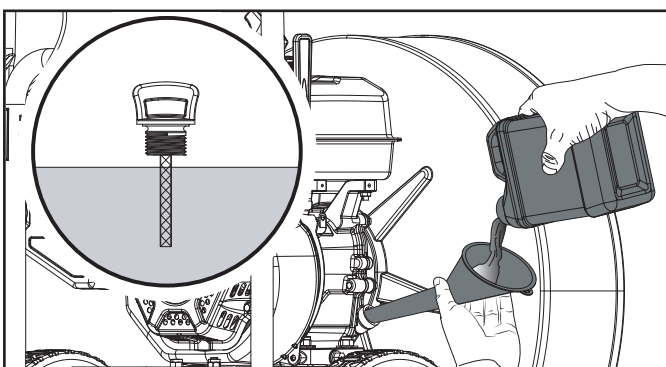

4. Check engine oil level before every use and add as needed.

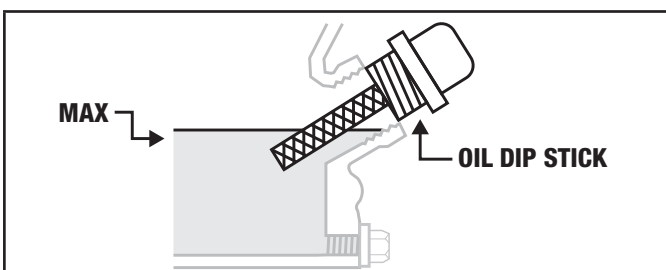

NOTICE

Once oil has been added, a visual check should show oil about 1-2 threads from running out of the fill hole.

If using the dipstick to check oil level, DO NOT screw in the dipstick while checking.

NOTICE

Check oil often during the break-in period. Refer to the Maintenance section for recommended service intervals.

CAUTION

The engine is equipped with a low oil shut-off and will stop when the oil level in the crankcase falls below the threshold level.

NOTICE

The first 5 hours of run time is the break-in period for the engine. During the break in period, it is recommended to use standard automotive, non-synthetic blended oils. After the break-in period synthetic oil, can be used but is not required. Adjusting throttle setting will increase/ decrease engine speed helping to seat piston rings. Avoid bogging or lugging the engine down and avoid prolonged running at constant RPM. After the 5 hour break-in period, change the oil.

NOTICE

Synthetic oil may be used after the 5 hour initial break-in period. Using synthetic oil does not decrease the recommended oil change interval. Full synthetic 5W-30 oil will aid in starting the engine in cold ambient < 41° F (5° C) temperatures.

NOTICE

Weather will affect engine oil and engine performance. Change the type of engine oil used based on weather conditions to suit the engine needs.

Add Fuel

CAUTION

Use regular unleaded gasoline with a minimum octane rating of 85 and an ethanol content of less than 10% by volume.

DO NOT light or smoke cigarettes.

DO NOT mix oil and gasoline.

DO NOT overfill the tank. Fill tank to approximately $\frac{1}{4}$ in. (6.4 mm) below the top of the tank to allow for gasoline expansion.

Always turn the blower off and let cool for minimum of two minutes before removing the gasoline cap.

Afterwards, loosen gasoline cap to relieve pressure from the gasoline tank.

Only fill or drain gasoline outdoors in a well-ventilated area.

Store fuel in a container approved for gasoline.

DO NOT pump gasoline directly into the blower at the gas station. Always use an approved fuel container to transfer the fuel to the gasoline tank.

DO NOT overfill the gasoline tank.



Always keep gasoline away from sparks, open flames, pilot lights, heat and other sources of ignition.

WARNING

Pouring gasoline too fast through the fuel screen may result in blow back of gasoline at the operator while filling.

WARNING

Always shut off engine before fueling. Never add fuel to a machine with a running or hot engine. Wait at least 2 minutes to allow for cool down before refueling. Move at least 50' (15 m) from refueling site before starting engine. Do not smoke and stay away from open flames and sparks. Failure to safely handle fuel could result in serious personal injury and or property damage.

1. Use clean, fresh, regular unleaded gasoline with a minimum octane rating of 87 and an ethanol content of less than 10% by volume.   
2. DO NOT mix oil with gasoline.
3. Remove the gasoline cap.
4. Slowly add gasoline to the tank. DO NOT OVERFILL. Gasoline can expand after filling. A minimum of $\frac{1}{4}$ in. (6.4 mm) of space left in the tank is required for gasoline expansion, although more than $\frac{1}{4}$ in. (6.4 mm) is recommended. Gasoline can be forced out of the tank as a result of expansion if overfilled, and can affect the stable running condition of the blower.

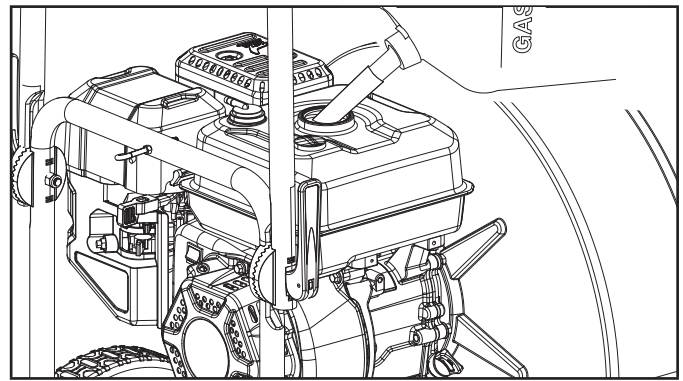

5. The approximate fuel level is shown on the fuel gauge on top of the fuel tank.

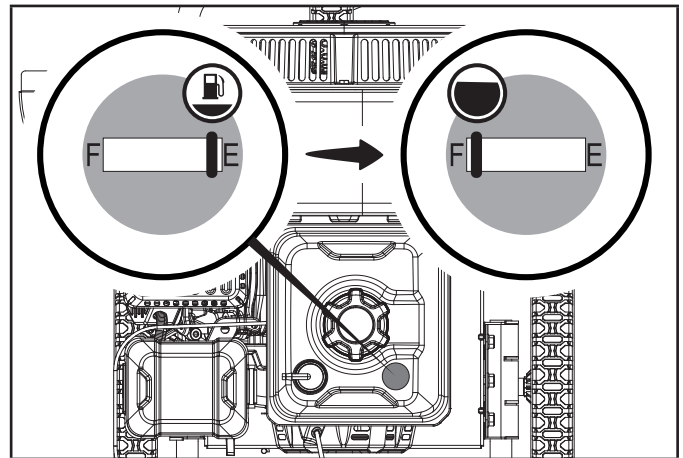

6. Screw on the gasoline cap and wipe away any spilled fuel.

NOTICE

Our engines work well with 10% or less ethanol blend gasoline. When using ethanol-gasoline blends there are some issues worth noting:

- Ethanol-gasoline blends can absorb more water than gasoline alone.
- These blends can eventually separate, leaving water or a watery goo in the tank, fuel valve and carburetor.
- The compromised gasoline can be drawn into the carburetor and cause damage to the engine and/or create power performance problems.
- There are only a few suppliers of fuel stabilizer that are formulated to work with ethanol blend fuels.
- Any damages or hazards caused by using improper fuel, improperly stored fuel, and/or improperly formulated stabilizers, are not covered by manufacturer's warranty. It is advisable to always shut off the fuel supply (where applicable - not every unit has a fuel shut off), run the engine to fuel starvation and drain the tank when the equipment is not in use for more than a 30-day period.
- See Storage instructions for extended non-use.

⚠ DANGER

The blower engine exhaust contains carbon monoxide, a colorless, odorless, poison gas. Breathing carbon monoxide will cause nausea, dizziness, fainting or death. If you start to feel dizzy or weak, get to fresh air immediately.

Operate the blower outdoors only in a well ventilated area.

DO NOT operate the blower inside any building, including garages, basements, crawlspaces and sheds, enclosure or compartment.

DO NOT allow exhaust fumes to enter a confined area through windows, doors, vents or other openings.

⚠ DANGER

Using an engine indoors **CAN KILL YOU IN MINUTES**. Engine exhaust contains carbon monoxide. This is a poison you cannot see or smell.

NEVER use inside a home or garage, **EVEN IF** doors and windows are open.

ONLY use **OUTSIDE** and far away from windows, doors, and vents.

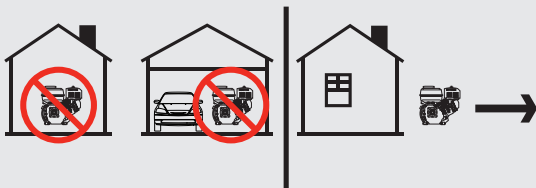

Install battery-operated carbon monoxide alarms or plug-in carbon monoxide alarms with battery back-up according to the manufacturer's instructions.

⚠ WARNING

Running engines produce heat. Severe burns can occur on contact. Combustible material can catch fire on contact.

DO NOT touch hot surfaces.

Avoid contact with hot exhaust gases.

Allow equipment to cool before touching.

Maintain at least 3 ft. (91.4 cm) of clearance on all sides to ensure adequate cooling.

Maintain at least 5 ft. (1.5 m) of clearance from combustible materials.

⚠ WARNING

Never run the unit without the blower fan cover installed. Use of an improperly assembled unit could result in serious personal injury.

🗨 NOTICE

In some State and local jurisdictions, operate power equipment during reasonable hours to comply with local noise ordinances. For more information, contact your State and local government for specific requirements.

Starting the Engine

1. Make certain the blower is on a flat, level surface.
2. Move the throttle lever on the handle to the "FAST" position (forward).

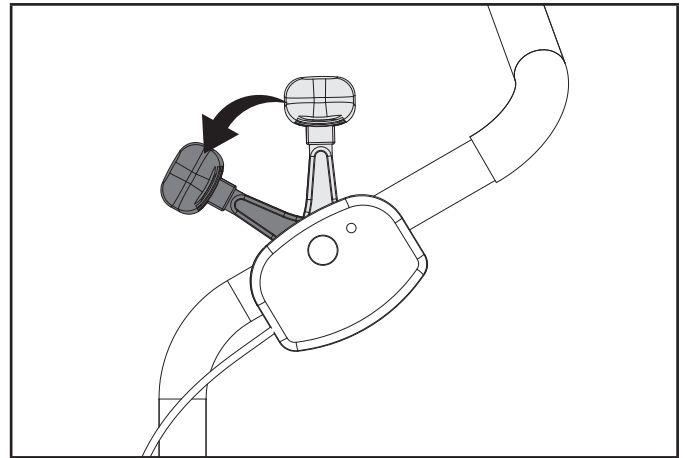

3. Move the choke lever to the "CHOKE" position.
4. Move the fuel valve to the "OPEN" position.

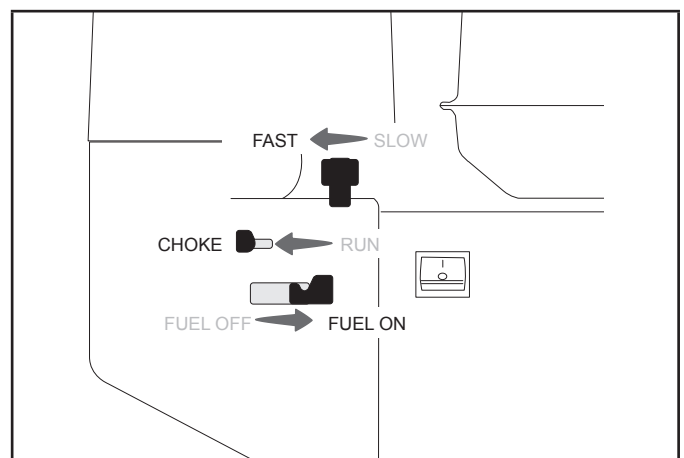
**⚠ WARNING**

Rapid retraction of the recoil cord could pull your hand and arm towards the engine faster than you can let go. Unintentional startup can result in entanglement, traumatic amputation or laceration. Broken bones, fractures, bruises or sprains could also result.

- Pull the starter cord slowly until resistance is felt and then pull rapidly.

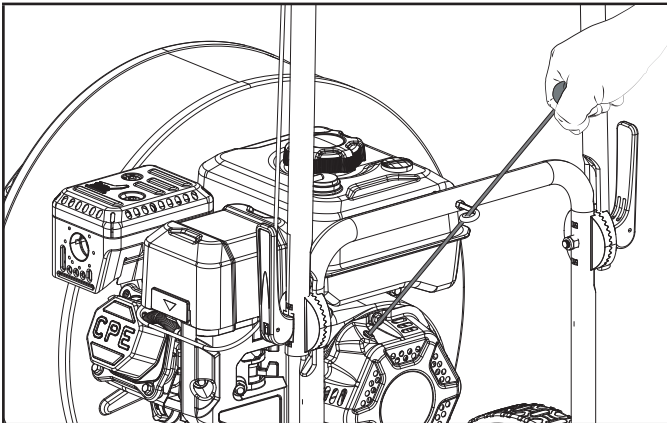

- As engine warms up, move the choke lever to the "RUN" position.

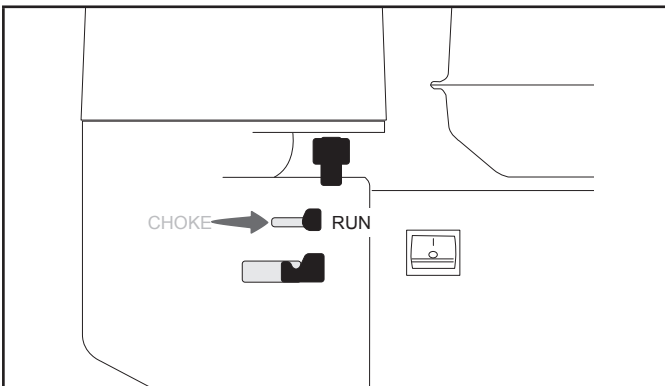

NOTICE

Keep choke lever in "CHOKE" position for 2 pulls of the recoil starter. After second pull, move choke lever to the "RUN" position for up to the next 3 pulls of the recoil starter. Too much choke leads to spark plug fouling/engine flooding due to the lack of incoming air. This will cause the engine not to start.

NOTICE

Allow engine to warm at least 30 seconds depending on ambient temperature. The colder the temperature, the longer the warm-up required.

Stopping the Engine

In an emergency, turn the engine switch to the "OFF" position.

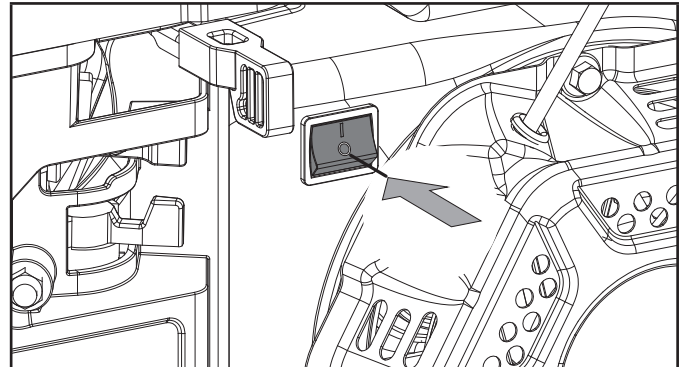

NOTICE

If the engine does not stop when the engine switch is moved to the "STOP" position, move the throttle to the slow speed position and slide the choke lever to the cold start (closed) position.

Under normal operation:

- Turn the fuel valve to the "OFF" position.

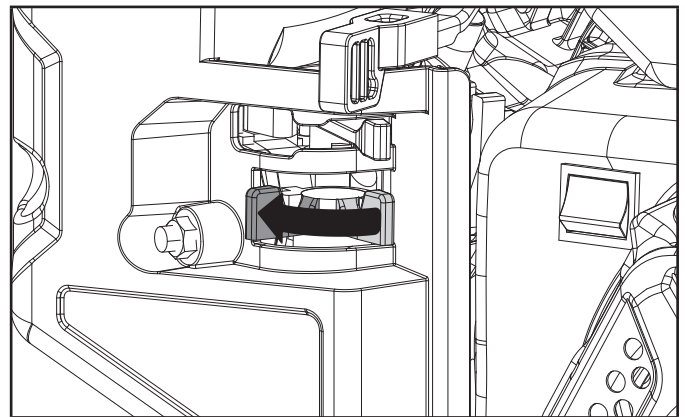

- Let the engine run until fuel starvation has stopped the engine. This usually takes few minutes.

Important: Always ensure that the fuel valve is in the "OFF" position when the engine is not in use.

NOTICE

If the engine will not be used for a period of two (2) weeks or longer, please see the Storage section for proper engine and fuel storage.

Blower Operation

⚠ WARNING

Always wear eye protection with side shields marked to comply with ANSI Z87.1. Failure to do so could result in objects being thrown into your eyes and other possible serious injuries.

Before Each Use Inspect the Blower

1. Always make sure the spark plug wire has been disconnected and engine has been grounded.
2. Always visually inspect the blower fan cover for loose fittings, cracks, or other damage.
3. DO NOT operate the blower if there is any indication of damage to parts or the unit.
4. DO NOT operate the blower if the discharge chute is clogged. Remove all debris before operation.
5. Always inspect the engine and make sure the oil level and fuel level are correct before operating.
6. Always inspect the work area for any distractions or factors that may prevent operator safety or proper operation.

Adjust the Handle Height

The handle height can be adjusted to a comfortable position for the user and, also be folded down for storage.

1. Pull the handle adjust lever outward to loosen the teeth engagement on the adjusters.

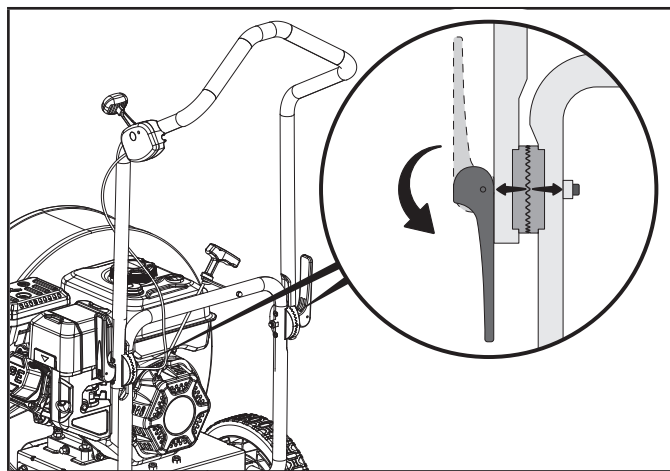

2. Move the handle to the desired height for user comfort.

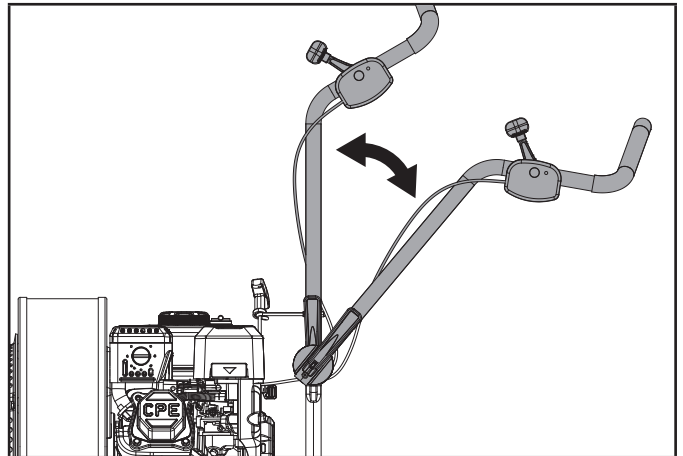

3. Ensure that the adjuster teeth are aligned to seat into each other then, push the handle adjust lever inward to lock back into place

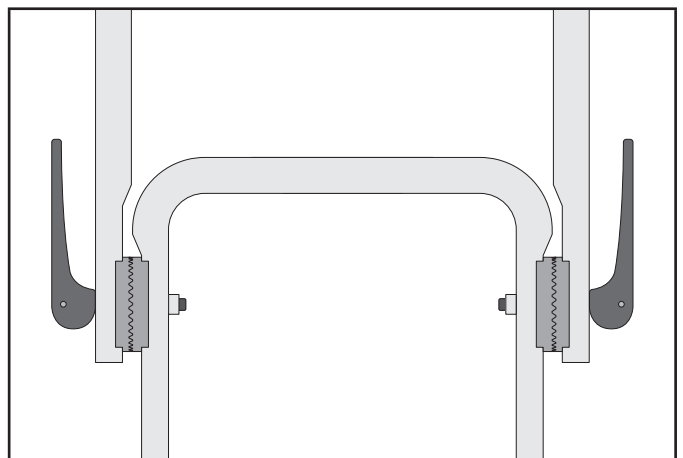
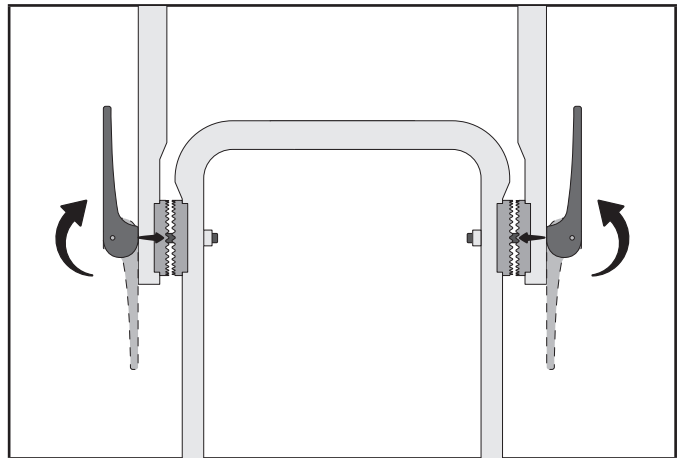

Vertical Air Flow Adjustment

The blower is equipped with an adjustable vertical air flow louver. The vertical air flow can be adjusted to 3 positions: Straight (level), 15 degrees up and 15 degrees down.

1. Stop the engine (see Stopping the Engine section)
2. Pull the index lever out of its existing hole.
3. Rotate the index lever to the desired position.
4. Release the index lever and allow it to insert into the desired hole.

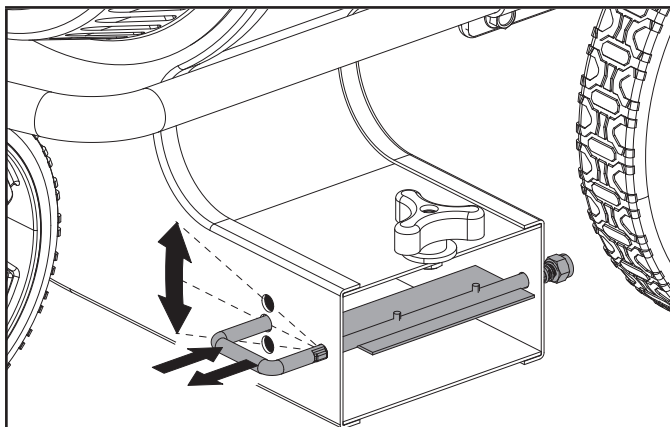

- 15° DOWN
- STRAIGHT/LEVEL
- 15° UP



5. To direct the air flow down 15 degrees, place the index lever into the top position. To direct the air flow level/straight, place the index lever into the middle position. To direct the air flow up 15 degrees, place the index lever into the bottom position.

Forward Air Flow Attachment

The blower includes a forward air flow attachment. Assembly of this attachment to the discharge chute will direct the air flow to the front of the blower instead of the side.

1. Stop the engine (see Stopping the Engine section).
2. Loosen the attachment knob located on top of the blower discharge chute.
3. Orient the attachment so “This Side Up for Use” is visible and the arrows are oriented toward the discharge chute.

4. Slide the attachment over the discharge chute. The slot on the top of the attachment will mate with the bolt of the attachment knob.
5. Hand-tighten the attachment knob to secure the attachment.

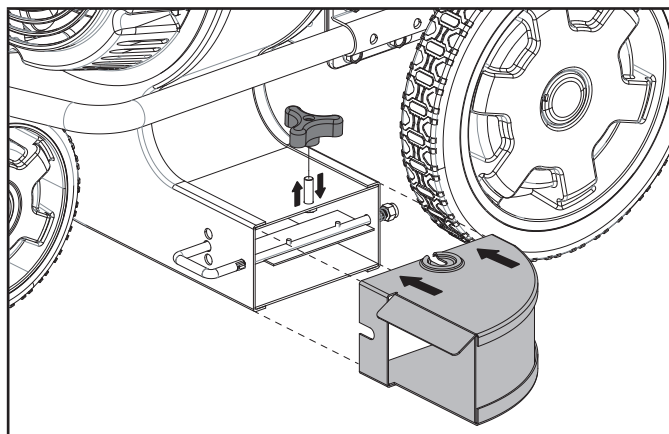

When not in use, the forward air flow attachment can be stored under the frame at the rear of the blower.

1. Turn the attachment so “This Side Up for Storage” is visible and the arrows are oriented towards the storage area.
2. Insert the attachment into frame opening, with the orientation identified on the label.
3. The edge of the attachment will be supported by a bracket under the frame.
4. Secure the attachment by forcing it upward and rotating it so the pin on the frame will insert into the slot on the attachment.

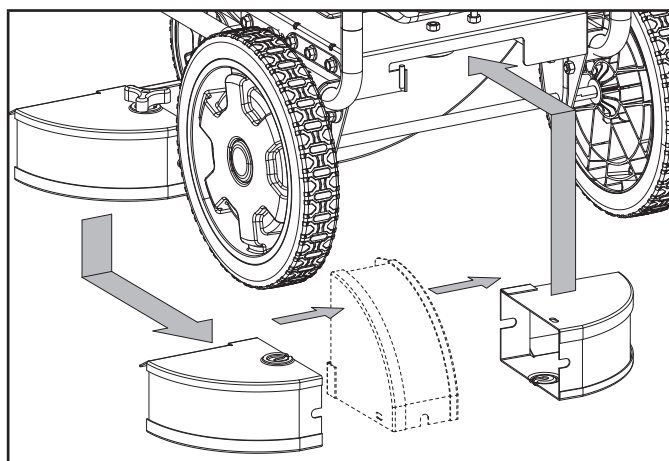

Front Wheel Swivel

This blower has a multi-function front wheel that can be locked in the front facing position or unlocked to swivel.

1. Pull up on the swivel lock lever and turn it a quarter turn to lock into the slot in the up position. This will allow the wheel to swivel 360 degrees.

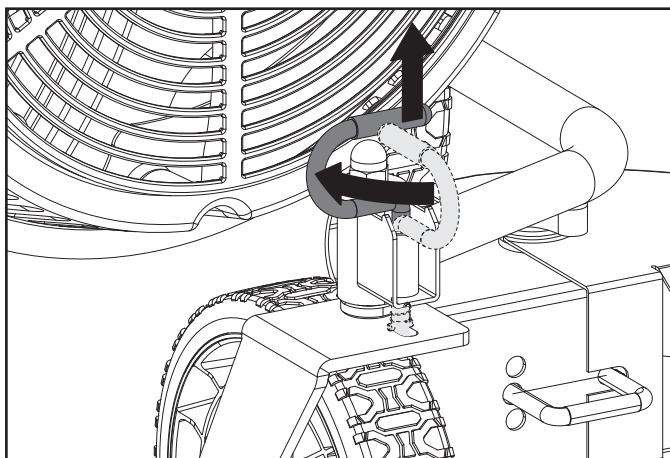

2. To put the wheel back into the locked forward-facing position, pull up on the swivel lock lever and turn it back a quarter of a turn and let it seat back into the down position with the pin locking into the hole on the wheel bracket. The wheel is now locked into the front facing position.

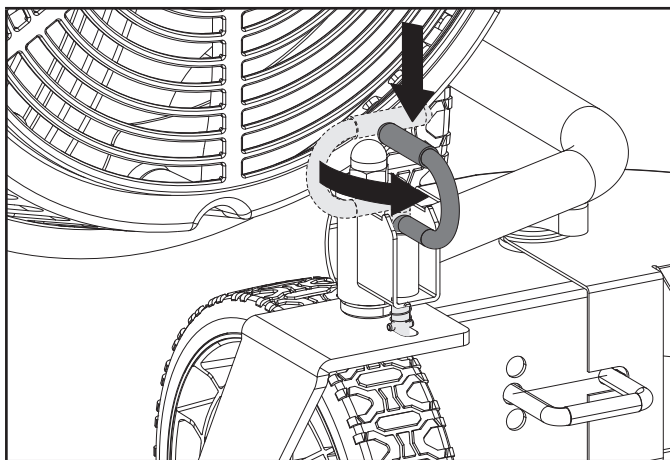

Operation at High Altitude

The density of air at high altitudes is lower than at sea level. Engine power is reduced as the air mass and air-fuel ratio decrease. Engine power and output will be reduced approximately 3½% for every 1000 ft. of elevation above sea level. At high altitudes increased exhaust emissions can also result due to the increased enrichment of the air fuel ratio. Other high-altitude issues can include hard starting, increased fuel consumption and spark plug fouling.

To alleviate high altitude issues other than the natural power loss, CPE can provide a high-altitude carburetor main jet. The

alternative main jet and installation instructions can be obtained by contacting our Technical Support Team. Installation instructions are also available in the Technical Bulletin area of the CPE website.

The part number and recommended minimum altitude for the application of the high-altitude carburetor main jet is listed in the following table.

In order to select the correct high-altitude main jet, it is necessary to identify the carburetor model. For this purpose, a code is stamped on the side of the carburetor.

Select the correct high-altitude jet part number corresponding to the carburetor code found on your particular carburetor.

Carb. Code	High Alt. Jet Part Number	Min. Altitude
16100-Z2M0311-00M0	16161-Z151710-00A1	3,000~6,000 ft. (914.4~1828.8 m)
	16161-Z151510-00A1	6,000~8,000 ft. (1828.8~2438.4m)
100748564-0001	100078586	Standard.
	100005750	3281-9843 ft. (1000-3000 m)

⚠ WARNING

Operation using the alternative main jet at elevations lower than the recommended minimum altitude can damage the engine. For operation at lower elevations, the originally supplied standard main jet must be used. Operating the engine with the wrong engine configuration at a given altitude may increase its emissions and decrease fuel efficiency and performance.

MAINTENANCE

Make certain that the blower is kept clean and stored properly. Only operate the unit on a flat, level surface in a clean, dry operating environment. DO NOT expose the unit to extreme conditions, excessive dust, dirt, moisture or corrosive vapors.

The owner/operator is responsible for all periodic maintenance. Complete all scheduled maintenance in a timely manner. Correct any issue before operating the blower. For service or parts assistance, contact our help line at 1-877-338-0999.

⚠ WARNING

Never operate a damaged or defective blower. Improper maintenance will void your warranty.

⚠ WARNING

Before inspecting, cleaning, or servicing the blower, shut off the engine. Wait for all moving parts to stop, disconnect spark plug wire and move it away from the spark plug. Failure to follow these instructions could result in personal injury or damage to the blower.

🗨 NOTICE

For emission control devices and systems, read and understand your responsibilities for service as stated in the Emission Control Warranty Statement of this manual.

⚠ WARNING

When servicing, use only genuine approved replacement parts. Use of any other parts could result in poor performance or damage the blower.

Cleaning the Blower**⚠ CAUTION**

DO NOT spray engine with water.

Water can contaminate the fuel system and can enter the engine through the cooling slots and damage the engine.

1. Use a damp cloth to clean exterior surfaces of the blower.
2. Use a soft bristle brush to remove dirt and oil.
3. Use an air compressor (25 PSI) to clear dirt and debris from the blower.
4. Inspect all air vents and cooling slots to ensure that they are clean and unobstructed.

Engine Oil Services

Check the engine oil level before each use and after every five hours of continuous operation. Running the engine when it is low on oil will quickly ruin the engine. It is recommended that you change the engine oil after every 10 hours of operation and even sooner when operating in extremely dirty or dusty conditions.

A. Check the Engine Oil Level

1. Park the blower on a level area and shut off the engine.
2. Clean around the oil dipstick to prevent dirt from falling into the crankcase.
3. Remove the dipstick and wipe it clean. Reinsert the dipstick (do not tighten) and remove it. Add oil as needed to bring the level up to the FULL mark. Wipe the dipstick clean each time the oil level is checked. Do not overfill.

4. Tighten dipstick securely.

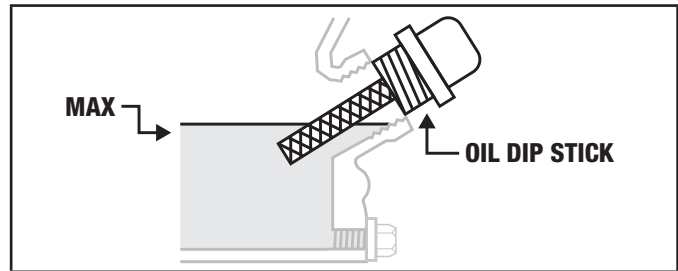
**B. Changing the Engine Oil****⚠ CAUTION**

DO NOT attempt to crank or start the engine before it has been properly filled with the recommended type and amount of oil. Damage to the blower as a result of failure to follow these instructions will void your warranty.

🗨 NOTICE

The recommended oil type is 10W-30 automotive oil.

Change oil when the engine is warm. Refer to the oil specification to select the proper grade for your operating environment.

1. Place the blower on a flat, level surface.
2. Clean around the oil drain plug to prevent dirt from falling into the crankcase. Remove oil drain plug with a 10mm socket (not included)

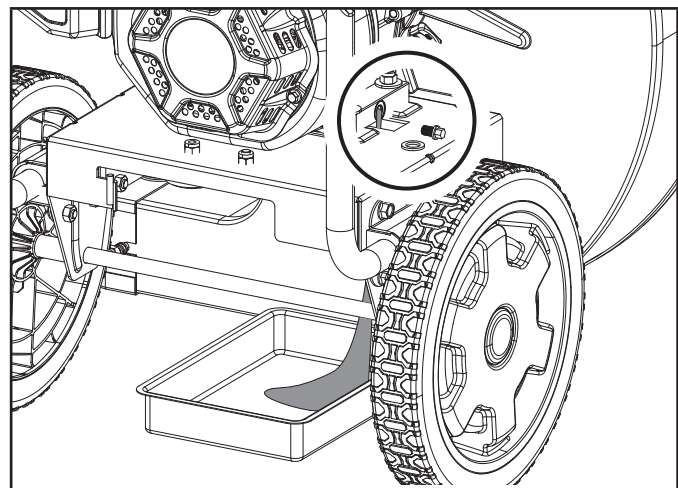
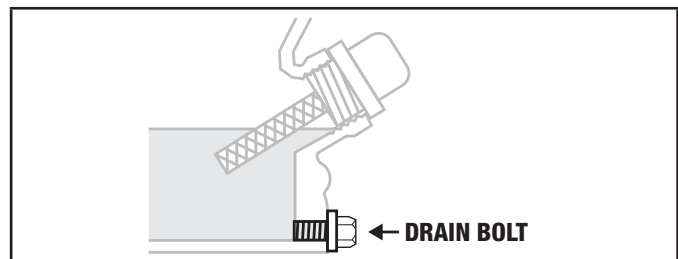

3. Allow the oil to drain completely into an appropriate container.
4. Replace the oil drain plug.
5. Remove the oil fill cap/dipstick to add oil.
6. Add oil according to Add Engine Oil in Assembly section.
7. DO NOT OVERFILL. Oil not included for routine maintenance.
8. Dispose of used oil at an approved waste management facility.

NOTICE

Once oil has been added, a visual check should show oil about 1-2 threads from running out of the fill hole. When using the dipstick to check oil level, DO NOT screw in the dipstick while checking.

Cleaning and Adjusting the Spark Plug(s)

1. Remove the spark plug cable from the spark plug.

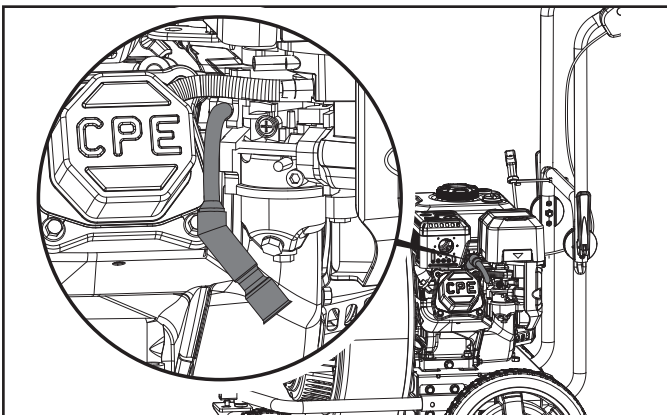

2. Use a spark plug socket tool (not included), or a 13/16 in. (21 mm) socket (not included) to remove the plug.
3. Inspect the electrode on the plug. It must be clean and not worn to produce the spark required for ignition.
4. Make certain the spark plug gap is 0.028-0.031 in. (0.7-0.8 mm).

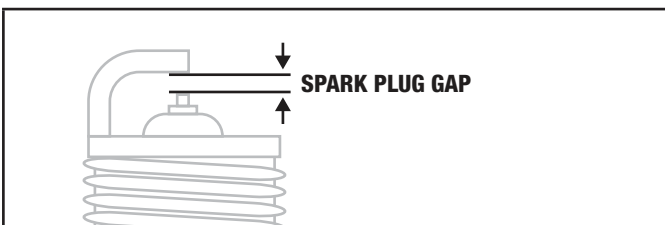

5. Refer to the spark plug types in Specifications when replacing the plug.
6. Firmly re-install the plug.
7. Attach the spark plug cable to the spark plug.

Cleaning the Air Filter

1. Using your finger, pry the outer tab up slightly and lift the air filter cover above the tab lock position.
2. Remove both air filter cover and air filter element.

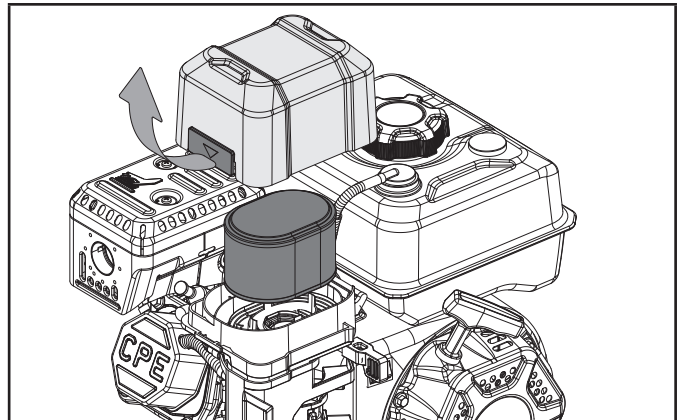

3. Wash in liquid detergent and water. Squeeze thoroughly dry in a clean cloth.
4. Saturate in clean engine oil.
5. Squeeze in a clean, absorbent cloth to remove all excess oil.
6. Place the filter in the assembly.
7. Reattach the air filter cover. Attach the side closest to the gas tank then pivot down to close. Make sure air filter cover snaps in place.

Cleaning the Spark Arrestor

1. If so equipped, allow the engine to cool completely before servicing the spark arrester.
2. Remove the screws holding the cover plate which retains the end of the spark arrester to the muffler.
3. Remove the spark arrester screen.
4. Carefully remove the carbon deposits from the spark arrester screen with a wire brush.
5. Replace the spark arrester if it is damaged.
6. Position the spark arrester on the muffler and attach with the screws removed in step 2.

CAUTION

Failure to clean the spark arrester will result in degraded engine performance.

NOTICE

Federal and local laws and administrative requirements indicate when and where spark arrestors are required. When ordered, spark arrestors are required for operation of this blower in National Forest lands. In California, this blower must not be used on any forest-covered land, brush-covered land, or grass-covered land unless the engine is equipped with a spark arrestor.

WARNING

Always check for fuel leaks before use. A leaking fuel cap is a hazard and must be replaced immediately. If any leaks are found, correct the problem before using the product. Failure to do so could result in a fire hazard that could cause serious personal injury, including equipment and property damage.

Adjusting the Governor**NOTICE**

Tampering or adjusting the factory set carburetor is a Federal Violation and will void your warranty coverage.

The air-fuel mixture is not adjustable. Tampering with the governor can damage your blower and will void your warranty. Contact our Technical Support Team at 1-877-338-0999 for all other service and/or adjustment needs.

Maintenance Schedule

Follow the service intervals indicated in the following maintenance schedule.

Service your blower more frequently when operating in adverse conditions.

Contact our Technical Support Team at 1-877-338-0999 to locate the nearest CPE certified service dealer for your blower or engine maintenance needs.

EVERY 8 HOURS OR DAILY

- Check oil level
- Clean around air intake and muffler

FIRST 5 HOURS

- Change oil

EVERY 50 HOURS OR EVERY SEASON

- Clean air filter
- Change oil if operating under heavy load or in hot environments

EVERY 100 HOURS OR EVERY SEASON

- Change oil
- Clean/adjust spark plug
- Check/adjust valve clearance*
- Clean spark arrestor
- Clean fuel tank and filter*

EVERY 250 HOURS

- Clean combustion chamber*

EVERY 3 YEARS

- Replace fuel line*

**To be performed by knowledgeable, experienced owners or Champion Power Equipment certified dealers.*

STORAGE

Refer to the Maintenance section for proper cleaning instructions.

1. Allow the blower to cool completely before storage.
2. Turn off the fuel supply at the fuel valve.
3. Clean the blower according to the instructions in the Maintenance section.
4. Store the unit in a clean, dry area out of direct sunlight.

Short Term Engine Storage (Up to 30 Days)

1. Allow the engine to cool completely before storage.
2. Clean engine according to the Maintenance section.
3. To extend the fuel storage life add a properly formulated fuel stabilizer to the tank.
4. Ensure the fuel valve is in the "OFF" position.

Long Term Engine Storage (30 Days – 1 Year)

1. Add a properly formulated fuel stabilizer to the tank.
2. Run the engine for a few minutes so the treated fuel cycles through the fuel system and carburetor.
3. Turn the fuel valve to the "OFF" position.
4. Let the engine run until fuel starvation has stopped the engine. This usually takes a few minutes.
5. The engine needs to cool completely before cleaning and storage.
6. Clean the engine according to the Maintenance section.
7. Change the oil according to the Maintenance section.
8. Remove the spark plug and pour about 1/2 oz. (14.9 mL) of oil into the cylinder. Crank the engine slowly to distribute the oil and lubricate the cylinder.
9. Reattach the spark plug.

WARNING

Never store the blower indoors or next to appliances where there is a source of heat, open flame, spark or pilot light as these conditions can ignite gasoline vapors. DO NOT store the blower near fertilizer or any corrosive material. Even with an empty fuel tank, gasoline vapors could ignite. When storing the blower for short or long periods of time, always be sure that the engine switch (where applicable) and the fuel valve (where applicable) are set in the "OFF" position.

NOTICE

The engine works well with 10% or less ethanol blend fuels. When using blended fuels, there are some issues worth noting:

- Ethanol-gasoline blends can absorb more water than gasoline alone.
- These blends can eventually separate, leaving water or a watery goo in the tank, fuel valve and carburetor.
- The compromised gasoline can be drawn into the carburetor and cause damage to the engine and/or create power performance problems.
- There are only a few suppliers of fuel stabilizer that are formulated to work with ethanol blend fuels.
- Any damages or hazards caused by using improper fuel, improperly stored fuel, and/or improperly formulated stabilizers, are not covered by manufacturer's warranty. It is advisable to always shut off the fuel supply (where applicable - not every unit has a fuel shut off), run the engine to fuel starvation and drain the tank when the equipment is not in use for more than a 30-day period.

NOTICE

To avoid possible damage to the threads, do not try to remove the plug from a hot aluminum cylinder head.

SPECIFICATIONS

Blower Specifications

Model	200947
Air Velocity*	Max 160 MPH (257.5 km/h) Max 1300 CFM (ft ³ /min)
Sound Pressure	85 dB(A) @ 20 ft. (6 m)
Wheel Diameter	12 in. (30.5 cm) Rear / 8 in. (20.3 cm) Front

**Rated per ANSI/OPEI B175.2*

Overall Dimensions

Net Weight	104 lb. (47 kg)
Length	35.9 in. (91.2 cm)
Width	26.8 in. (68 cm)
Height	47.4 in. (120.5 cm)

Engine Specifications

Model	R224P / GB225
Displacement (cc)	224
Type	4-Stroke OHV
Start Type	Recoil

Spark Plug Specifications

OEM	F6RTC
Replacement	NGK BPR6ES or equivalent
Gap (in/mm)	0.028 - 0.031 / 0.7 - 0.8

Valve Specifications

Intake Clearance (in/mm)	0.0039 - 0.0059 / 0.1 - 0.15
Exhaust Clearance (in/mm)	0.0059 - 0.0079 / 0.15 - 0.2

NOTICE

A technical bulletin regarding valve adjustment procedures is available at www.championpowerequipment.com.

Oil Specifications

NOTICE

Temperature will affect engine oil and engine performance. Change the type of engine oil used based on temperature shown in the "Recommended Engine Oil Type" table.

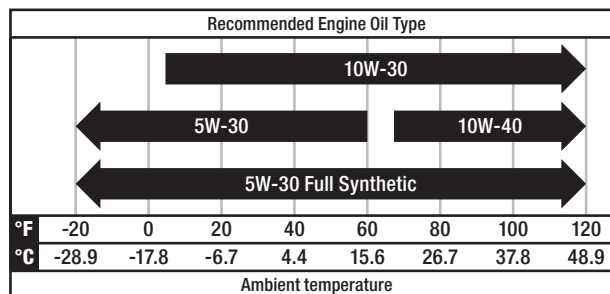

Oil Capacity (fl. oz/mL) 16.9 / 500

Fuel Specifications

Use regular unleaded gasoline with a minimum octane rating of 87 and an ethanol content of less than 10% by volume. DO NOT USE E15 or E85. DO NOT OVERFILL.

Fuel Capacity (gal/L) 0.82/3.1

Important Message About Temperature

NOTICE

An important message about temperature: Your product is designed and rated for continuous operation at ambient temperatures up to 104°F (40°C). When needed, it may be operated at temperatures ranging from 5°F (-15°C) to 122°F (50°C) for short periods of time. If exposed to temperatures outside this range during storage, it should be brought back within this range before operation. In any event, the product must always be operated outdoors, in a well-ventilated area and away from doors, windows and vents.

Starting Temperature Range (°F/°C) 5 to 104/-15 to 40

TROUBLESHOOTING

Problem	Cause	Solution
Engine does not start	Spark plug wire disconnected.	Reconnect wire.
	Engine Throttle Control Lever incorrectly set.	Put lever in START position.
	Fuel tank empty.	Add fuel.
	Choke control (if so equipped) in incorrect position.	Move to CHOKE position.
	Stale gasoline.	Drain fuel and add fresh fuel.
	Dirty air filter	Clean or replace filter
	Defective or incorrectly gapped spark plug	Inspect spark plug
	Carburetor out of adjustment	Contact Technical Support Team
	Misadjusted throttle control	Contact Technical Support Team
	Dirt or water in fuel tank	Contact Technical Support Team
Engine Runs Poorly	Defective or incorrectly gapped spark plug	Inspect the spark plug
	Dirty air filter	Clean or replace filter
	Carburetor out of adjustment	Contact Technical Support Team
	Stale gasoline.	Replace with fresh gasoline
	Dirt or water in fuel tank	Contact Technical Support Team
	Engine cooling system clogged	Clean air-cooling system
Engine Overheats	Engine cooling system clogged	Clean air-cooling system
	Carburetor out of adjustment	Contact Technical Support Team
	Oil level is low	Check oil level
Excessive vibration/noise	Loose parts	Check and tighten all fasteners
	See engine problems above	See engine solutions above
Engine does not shut off	Misadjusted throttle control or ignition switch	Contact Technical Support Team
Air flow is low	Throttle is in slow position	Ensure throttle is in fast position
	Air intake is clogged	Clean any debris from the air intake
	Air discharge is clogged	Clear any obstructions from the discharge

For further technical support:

Technical Support Team
Toll Free 1-877-338-0999
support@championpowerequipment.com

WARRANTY*

CHAMPION POWER EQUIPMENT
2 YEAR LIMITED WARRANTY

Warranty Qualifications

To register your product for warranty and FREE lifetime call center technical support please visit:

<https://www.championpowerequipment.com/register>

To complete registration you will need to include a copy of the purchase receipt as proof of original purchase. Proof of purchase is required for warranty service. Please register within ten (10) days from date of purchase.

Repair/Replacement Warranty

CPE warrants to the original purchaser that the mechanical and electrical components will be free of defects in material and workmanship for a period of two years (parts and labor) from the original date of purchase and 180 days (parts and labor) for commercial and industrial use. Transportation charges on product submitted for repair or replacement under this warranty are the sole responsibility of the purchaser. This warranty only applies to the original purchaser and is not transferable.

Do Not Return The Unit To The Place Of Purchase

Contact CPE's Technical Service and CPE will troubleshoot any issue via phone or e-mail. If the problem is not corrected by this method, CPE will, at its option, authorize evaluation, repair or replacement of the defective part or component at a CPE Service Center. CPE will provide you with a case number for warranty service. Please keep it for future reference. Repairs or replacements without prior authorization, or at an unauthorized repair facility, will not be covered by this warranty.

Warranty Exclusions

This warranty does not cover the following:

Normal Wear

Products with mechanical and electrical components need periodic parts and service to perform well. This warranty does not cover repair when normal use has exhausted the life of a part or the equipment as a whole.

Installation, Use and Maintenance

This warranty will not apply to parts and/or labor if the product is deemed to have been misused, neglected, involved in an accident, abused, loaded beyond the product's limits or modified. Normal maintenance is not covered by this warranty and is not required to be performed at a facility or by a person authorized by CPE.

Other Exclusions

This warranty excludes:

- Cosmetic defects such as paint, decals, etc.
- Wear items such as starter pulleys, starter ropes, filter elements, belts, blower fans, impeller blades, blower and/or vacuum tubes, vacuum bag and straps (where applicable), etc.
- Failures due to acts of God and other force majeure events beyond the manufacturer's control.
- Problems caused by parts that are not original Champion Power Equipment parts.

Limits of Implied Warranty and Consequential Damage

Champion Power Equipment disclaims any obligation to cover any loss of time, use of this product, freight, or any incidental or consequential claim by anyone from using this product. THIS WARRANTY AND THE ATTACHED U.S. EPA and/or CARB EMISSION CONTROL SYSTEM WARRANTIES (WHEN APPLICABLE) ARE IN LIEU OF ALL OTHER WARRANTIES, EXPRESS OR IMPLIED, INCLUDING WARRANTIES OF MERCHANTABILITY OR FITNESS FOR A PARTICULAR PURPOSE.

A unit provided as an exchange will be subject to the warranty of the original unit. The length of the warranty governing the exchanged unit will remain calculated by reference to the purchase date of the original unit.

This warranty gives you certain legal rights which may change from state to state or province to province. Your state or province may also have other rights you may be entitled to that are not listed within this warranty.

Contact Information

Address

Champion Power Equipment, Inc.
6370 S Pioneer Way, Unit 101
Las Vegas, NV 89113 USA
www.championpowerequipment.com

Customer Service

Toll Free: 1-877-338-0999
info@championpowerequipment.com
Fax no.: 1-562-236-9429

Technical Service

Toll Free: 1-877-338-0999
tech@championpowerequipment.com

📞 EMERGENCY 24 HOUR SUPPORT: 1-562-204-1188

**CHAMPION POWER EQUIPMENT, INC. (CPE),
THE UNITED STATES ENVIRONMENTAL PROTECTION AGENCY (U.S. EPA)
AND THE CALIFORNIA AIR RESOURCES BOARD (CARB) EMISSION CONTROL SYSTEM WARRANTY**

Your Champion Power Equipment (CPE) engine complies with both the U.S. EPA and state of California Air Resources Board (CARB) emissions regulations.

YOUR WARRANTY RIGHTS AND OBLIGATIONS:

The US EPA, California Air Resources Board, and CPE are pleased to explain the Federal and California Emission Control Systems warranty on your 2023 small off-road engine (SORE) and equipment. In the United States and California, new small off-road engines (SORE) and new equipment that use small off-road engines (SORE) must be designed, built and equipped to meet the State's stringent anti-smog standards.

CPE must warrant the emission control system on your small off-road engine (SORE) and equipment for the period of time listed below, provided there has been no abuse, neglect or improper maintenance of your small off-road engine (SORE) and equipment leading to the failure of the emission control system.

Your emission control system may include parts such as the carburetor, fuel-injection system, the ignition system, catalytic converter, fuel tanks, fuel lines (for liquid fuel and fuel vapors), fuel caps, valves, canisters, filters, clamps, connectors, and other associated components. Also included may be hoses, belts, and other emission related assemblies. Where a warrantable condition exists, CPE will repair your small off-road engine (SORE) and equipment at no cost to you including diagnosis, parts and labor.

MANUFACTURER'S WARRANTY COVERAGE:

This Emissions Control System is warranted for two years. If any emissions-related part on your small off-road engine (SORE) and equipment is defective, the part will be repaired or replaced by CPE.

OWNER WARRANTY RESPONSIBILITIES:

As the small off-road engine (SORE) and equipment owner, you are responsible for the performance of the required maintenance listed in your Owner's Manual. CPE recommends that you retain all your receipts covering maintenance on your small off-road engine (SORE) and equipment, but CPE cannot deny warranty coverage solely for the lack of receipts or for your failure to ensure the performance of all scheduled maintenance.

As the small off-road engine (SORE) and equipment owner, you should be aware that CPE may deny you warranty coverage if your small off-road engine (SORE) and equipment or a part has failed due to abuse, neglect, improper maintenance or unapproved modifications.

You are responsible for presenting your small off-road engine (SORE) and equipment to an Authorized CPE service outlet or alternate service outlet as described in (3)(f.) below, CPE dealer or CPE, Las Vegas, NV. as soon as a problem exists. The warranty repairs shall be completed in a reasonable amount of time, not to exceed 30 days.

If you have any questions regarding your warranty coverage, you should contact:

Champion Power Equipment, Inc.
Customer Service
6370 S Pioneer Way, Unit 101
Las Vegas, NV 89113
1-877-338-0999
tech@championpowerequipment.com

EMISSION CONTROL SYSTEM WARRANTY

The following are specific provisions relative to your Emission Control System (ECS) Warranty Coverage.

- 1. APPLICABILITY:** This warranty shall apply to 1995 and later model year California small off-road engines (SORE) (for other states, 1997 and later model year engines). The ECS Warranty Period shall begin on the date the new engine or equipment is delivered to its original, end-use purchaser, and shall continue for 24 consecutive months thereafter.
- 2. GENERAL EMISSIONS WARRANTY COVERAGE**

CPE warrants to the original, end-use purchaser of the new engine or equipment and to each subsequent purchaser that each of its small off-road engines (SORE) is:

 - 2a. Designed, built and equipped so as to conform to U.S. EPA emissions standards for spark- ignited engines at or below 19 kilowatts and all applicable regulations adopted by the California Air Resources Board; and
 - 2b. Free from defects in materials and workmanship that cause the failure of a warranted part to be identical in all material respects to the part as described in the engine manufacturer's application for certification for a period of two years.
- 3. THE WARRANTY ON EMISSION-RELATED PARTS WILL BE INTERPRETED AS FOLLOWS:**
 - 3a. Any warranted part that is not scheduled for replacement as required maintenance in the Owner's Manual shall be warranted for the ECS Warranty Period. If any such part fails during the ECS Warranty Period, it shall be repaired or replaced by CPE according to Subsection "d" below. Any such part repaired or replaced under the ECS Warranty shall be warranted for a time not less than the remainder of the ECS Warranty Period.
 - 3b. Any warranted, emissions-related part which is scheduled only for regular inspection as specified in the Owner's Manual shall be warranted for the ECS Warranty Period. A statement in such written instructions to the effect of "repair or replace as necessary" shall advise owners of the warranty coverage for emission related parts. Replacement within the warranty period is covered by the warranty and shall not reduce the ECS Warranty Period. Any such part repaired or replaced under the ECS Warranty shall be warranted for a time not less than the remainder of the ECS Warranty Period.
 - 3c. Any warranted, emissions-related part which is scheduled for replacement as required maintenance in the Owner's Manual shall be warranted for the period of time prior to the first scheduled replacement point for that part. If the part fails prior to the first scheduled replacement, the part shall be repaired or replaced by CPE according to Subsection "d" below. Any such emissions-related part repaired or replaced under the ECS Warranty, shall be warranted for a time not less than the remainder of the ECS Warranty Period prior to the first scheduled replacement point for such emissions-related part.
 - 3d. Repair or replacement of any warranted, emissions-related part under this ECS Warranty shall be performed at no charge to the owner at a CPE Authorized Service Outlet.
 - 3e. The owner shall not be charged for diagnostic labor which leads to the determination that a part covered by the ECS Warranty is in fact defective, provided that such diagnostic work is performed at a CPE Authorized Service Outlet.
 - 3f. CPE shall pay for covered emissions warranty repairs at non-authorized service outlets under the following circumstances:
 - i. The service is required in a population center with a population over 100,000 according to U.S. Census 2000 without a CPE Authorized Service Outlet AND
 - ii. The service is required more than 100 miles from a CPE Authorized Service Outlet. The 100 mile limitation does not apply in the following states: Alaska, Arizona, Colorado, Hawaii, Idaho, Montana, Nebraska, Nevada, New Mexico, Oregon, Texas, Utah and Wyoming.
 - 3g. CPE shall be liable for damages to other original engine components or approved modifications proximately caused by a failure under warranty of an emission-related part covered by the ECS Warranty.
 - 3h. Throughout the ECS Warranty Period, CPE must maintain a supply of warranted emission-related parts sufficient to meet the expected demand for such emission-related parts and must obtain additional parts if that supply is exhausted.
 - 3i. Any CPE Authorized and approved emission-related replacement part that do not increase the exhaust or evaporative emissions of the engine or emissions control system may be used in the performance of any ECS Warranty maintenance or repair and will be provided without charge to the owner. Such use shall not reduce CPE's warranty obligation.
 - 3j. Unapproved add-on or modified parts may not be used to modify or repair a CPE engine. Such use voids this ECS Warranty and shall be sufficient grounds for disallowing an ECS Warranty claim. CPE shall not be liable hereunder for failures of any warranted parts of a CPE engine caused by the use of such an unapproved add-on or modified part.

EMISSION-RELATED PARTS INCLUDE THE FOLLOWING: (using those portions of the list applicable to the engine)

Systems covered by this warranty	Parts Description
Fuel Metering System	Fuel regulator, Carburetor and internal parts
Air Induction System	Air cleaner, Intake manifold
Ignition System	Spark plug and parts, Magneto ignition system
Exhaust System	Exhaust manifold, catalytic converter
Miscellaneous Parts	Tubing, Fittings, Seals, Gaskets, and Clamps associated with these listed systems.
Evaporative Emissions	Fuel Tank, Fuel Cap, Fuel Lines (for liquid fuel and fuel vapors), Fuel Line Fittings, Clamps, Pressure Relief Valves, Control Valves, Control Solenoids, Electronic Controls, Vacuum Control Diaphragms, Control Cables, Control Linkages, Purge Valves, Gaskets, Liquid/Vapor Separator, Carbon Canister, Canister Mounting Brackets, Carburetor Purge Port Connector

TO OBTAIN WARRANTY SERVICE:

You must take your CPE engine or the product on which it is installed, along with your warranty registration card or other proof of original purchase date, at your expense, to any Champion Power Equipment dealer who is authorized by Champion Power Equipment, Inc. to sell and service that CPE product during his normal business hours. Alternate service locations defined in Section (3)(f.) above must be approved by CPE prior to service. Claims for repair or adjustment found to be caused solely by defects in material or workmanship will not be denied because the engine was not properly maintained and used.

If you have any questions regarding your warranty rights and responsibilities, or to obtain warranty service, please write or call Customer Service at Champion Power Equipment, Inc.

Champion Power Equipment, Inc.
6370 S Pioneer Way, Unit 101
Las Vegas, NV 89113
1-877-338-0999
Attn.: Customer Service
tech@championpowerequipment.com