

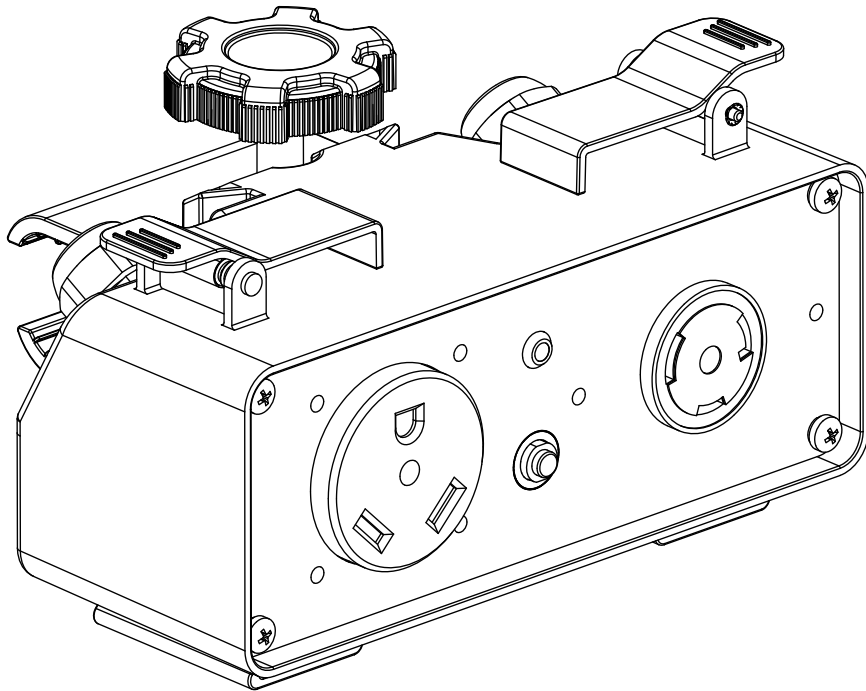

MODEL #BD201103



PARTS INFORMATION

PARALLEL KIT

SERIAL NUMBER RANGE: ALL



To order replacement parts please visit:

black-diamond.com

or call **1-888-376-7375**.

TABLE OF CONTENTS

Parts Diagram **3**

Parts List **4**

PARTS DIAGRAM

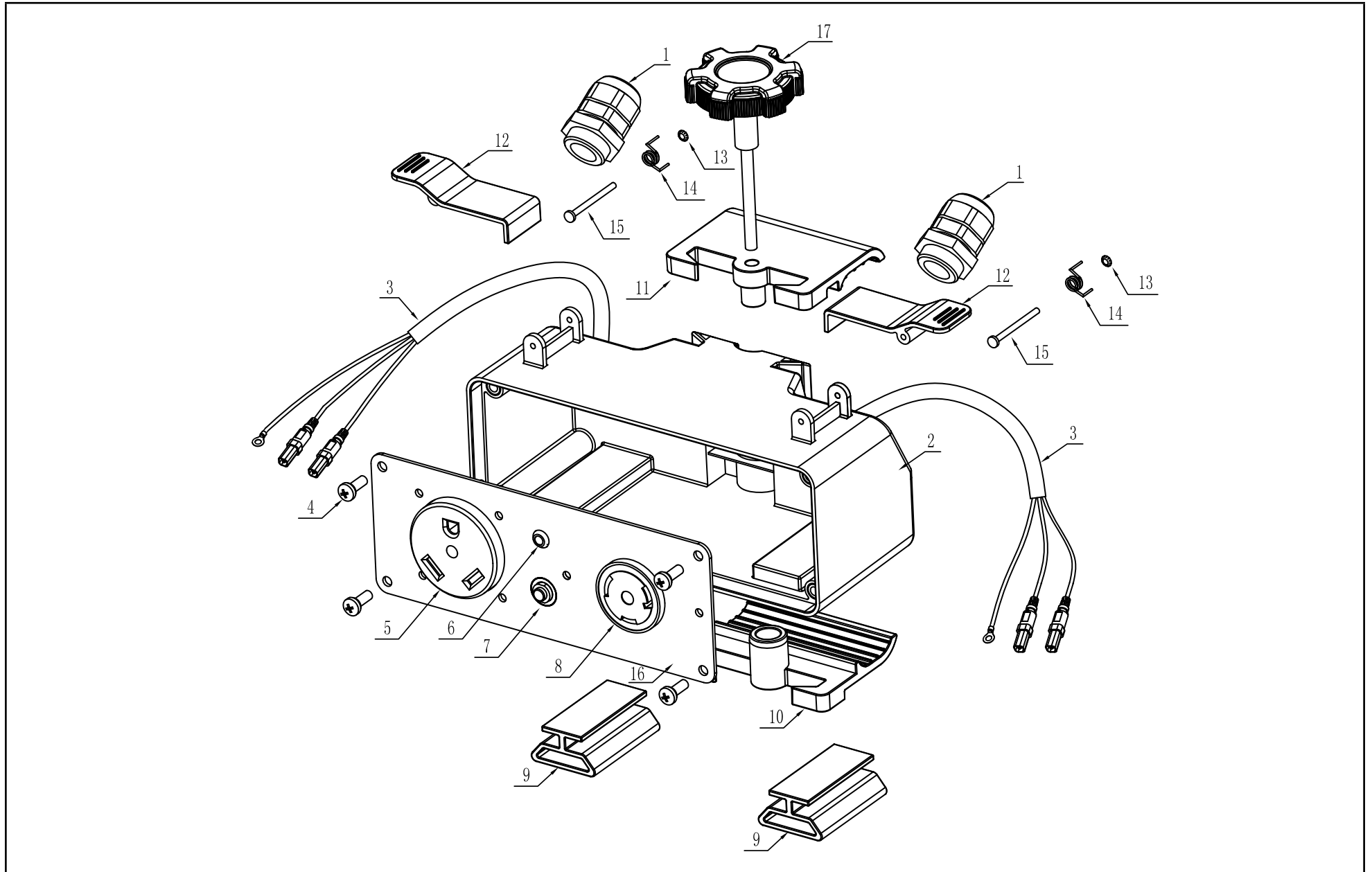

PARTS LIST

#	Part Number	Description	Qty.
1	XIP-C-01	Waterproof Joint, Cable, PG16	2
2	XIP-C-02	Control Box, Flame retardant PP	1
3	XIP-C-03	Parallel Plug, Wire 1050 mm, Red	2
4	XIP-C-04	Parallel Plug, Wire 1050 mm, Black	2
5	XIP-C-05	Screw/washer assembly, M5 x 16	4
6	XIP-C-06	TT-30R Receptacle	1
7	XIP-C-07	LED light, Green	1
8	XIP-C-08	30Amp Circuit Breaker	1
9	XIP-C-09	L5-30R Receptacle	1
10	XIP-C-10	Rubber Pad	2
11	XIP-C-11	Bottom Clamp, PA6	1
12	XIP-C-12	Upper Clamp, PA6	1
13	XIP-C-13	Wire Clip	2
14	XIP-C-14	Snap Ring	2
15	XIP-C-15	Spring	2
16	XIP-C-16	Pin Shaft, 3 x 40 mm	2
17	XIP-C-17	Control Panel	1
18	XIP-C-18	Knob M6 x 60 mm, PA	1