



OPERATOR'S MANUAL

MODEL #BD201103

PARA LINK PARALLEL KIT



Intertek



or visit black-diamond.com

SAVE THESE INSTRUCTIONS. This manual contains important safety precautions which should be read and understood before operating the product. Failure to do so could result in serious injury. This manual should remain with the product.

Specifications, descriptions and illustrations in this manual are as accurate as known at the time of publication, but are subject to change without notice.

**TAKE IT
OUTSIDE™**



CARBON MONOXIDE KILLS

CARBON MONOXIDE SAFETY: THE BIG PICTURE

As the only safe way to use a portable generator, taking your generator outside is absolutely mandatory to keep your family safe from carbon monoxide. But there's even more you can do. By educating yourself about all carbon monoxide risks, you'll be better prepared to protect your family from this colorless, odorless threat.



**ALWAYS READ
THE OPERATOR'S
MANUAL FIRST**



KNOW THE SYMPTOMS

- Headache
- Nausea
- Shortness of breath
- Dizziness
- Fatigue

**STAY ALERT WITH CARBON
MONOXIDE DETECTORS**

**KEEP IT OUTSIDE AND AWAY FROM
DOORS, WINDOWS, AND GARAGES**

**IF YOU FEEL SYMPTOMS,
LEAVE RIGHT AWAY**

**POINT FUMES AWAY FROM
NEARBY PEOPLE**

www.TakeYourGeneratorOutside.com

TABLE OF CONTENTS

Table of Contents	3
Introduction	4
Safety Definitions	4
Important Safety Instructions	5
Safety Symbols	7
Controls and Features	8
Control Panel	8
Assembly and Operation	9
Paralleling Two Inverters	9
Adjusting the Anti-Vibration Wedges	10
Cable Storage	10
Specifications	11
Specifications	11
Warranty	12
Warranty Qualifications	12
Repair/Replacement Warranty	12
Do Not Return The Unit To The Place Of Purchase	12
Warranty Exclusions	12
Other Exclusions	12
Limits of Implied Warranty and Consequential Damage	12
Contact Information	12

INTRODUCTION

Congratulations on your purchase of a Black Diamond product. Black Diamond designs, builds, and supports all of our products to strict specifications and guidelines. With proper product knowledge, safe use, and regular maintenance, this product should bring years of satisfying service.

Every effort has been made to ensure the accuracy and completeness of the information in this manual at the time of publication, and we reserve the right to change, alter and/or improve the product and this document at any time without prior notice.

Black Diamond highly values how our products are designed, manufactured, operated, and serviced as well as providing safety to the operator and those around the generator. Therefore, it is **IMPORTANT** to review this product manual and other product materials thoroughly and be fully aware and knowledgeable of the assembly, operation, dangers and maintenance of the product before use. Fully familiarize yourself, and make sure others who plan on operating the product fully familiarize themselves too, with the proper safety and operation procedures before each use. Please always exercise common sense and always err on the side of caution when operating the product to ensure no accident, property damage, or injury occurs. We want you to continue to use and be satisfied with your Black Diamond product for years to come.

When contacting Black Diamond/Champion Power Equipment about parts and/or service, you will need to supply the complete model and serial numbers of your product. Transcribe the information found on your product's dataplate label to the table below

BLACK DIAMOND TECHNICAL SUPPORT TEAM

1-888-376-7375

MODEL NUMBER

BD201103

SERIAL NUMBER

DATE OF PURCHASE

PURCHASE LOCATION

SAFETY DEFINITIONS

The purpose of safety symbols is to attract your attention to possible dangers. The safety symbols, and their explanations, deserve your careful attention and understanding. The safety warnings do not by themselves eliminate any danger. The instructions or warnings they give are not substitutes for proper accident prevention measures.

DANGER

DANGER indicates a hazardous situation which, if not avoided, will result in death or serious injury.

WARNING

WARNING indicates a hazardous situation which, if not avoided, could result in death or serious injury.

CAUTION

CAUTION indicates a hazardous situation which, if not avoided, could result in minor or moderate injury.

NOTICE

NOTICE indicates information considered important, but not hazard-related (e.g., messages relating to property damage).

IMPORTANT SAFETY INSTRUCTIONS

⚠ WARNING

Cancer and Reproductive Harm – www.P65Warnings.ca.gov

⚠ DANGER

Generator exhaust contains carbon monoxide, a colorless, odorless, poisonous gas. Breathing carbon monoxide will cause nausea, dizziness, fainting or death. If you start to feel dizzy or weak, get to fresh air immediately.

OPERATE GENERATOR OUTDOORS ONLY IN A WELL VENTILATED AREA AND POINT EXHAUST AWAY.

DO NOT operate the generator inside any building, including garages, basements, crawlspaces and sheds, enclosure or compartment, including the generator compartment of a recreational vehicle.

DO NOT allow exhaust fumes to enter a confined area through windows, doors, vents or other openings.

⚠ DANGER

Using a generator indoors **CAN KILL YOU IN MINUTES.** Generator exhaust contains carbon monoxide. This is a poison you cannot see or smell.

NEVER use inside a home or garage, **EVEN IF** doors and windows are open.

ONLY use **OUTSIDE** and far away from windows, doors, and vents.

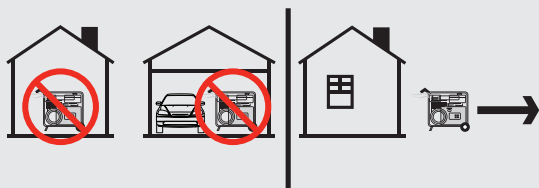

Install battery-operated carbon monoxide alarms or plug-in carbon monoxide alarms with battery back-up according to the manufacturer's instructions.

⚠ WARNING

Although the generator contains a spark arrester, maintain a minimum distance of 5 ft. (1.5 m) from dry vegetation to prevent fires.

⚠ DANGER

Operate equipment with guards in place.

Rotating parts can entangle hands, feet, hair, clothing and/or accessories. Traumatic amputation or severe laceration can result.

Keep hands and feet away from rotating parts.

Tie up long hair and remove jewelry.

DO NOT wear loose-fitting clothing, dangling drawstrings or items that could become caught.

⚠ DANGER

Generator produces powerful voltage.

DO NOT touch bare wires or receptacles.

DO NOT use electrical cords that are worn, damaged or frayed.

DO NOT operate generator in wet weather.

DO NOT allow children or unqualified persons to operate or service the generator.

Use a ground fault circuit interrupter (GFCI) in damp areas and areas containing conductive material such as metal decking.

Connection to your home's electrical system requires a listed 30A transfer switch installed by a licensed electrician and approved by the local authority having jurisdiction. The connection must isolate the generator from the utility power and must comply with all applicable laws and electrical codes.

⚠ WARNING

Do not use generator for medical and life support uses.

In case of emergency, call 911 immediately.

NEVER use this product to power life support devices or life support appliances.

NEVER use this product to power medical devices or medical appliances.

Inform your electricity provider immediately if you or anyone in your household depends on electrical equipment to live.

Inform your electrical provider immediately if a loss of power would cause you or anyone in your household to experience a medical emergency.

IMPORTANT SAFETY INSTRUCTIONS

⚠ WARNING

Spark from removed spark plug wire can result in fire or electrical shock.

When servicing the generator:

Disconnect the spark plug wire and place it where it cannot contact the plug or any other metal object.

DO NOT check for spark with the plug removed.

Use only approved spark plug testers.

⚠ WARNING

Running engines produce heat. Severe burns can occur on contact. Combustible material can catch fire on contact.

DO NOT touch hot surfaces.

Avoid contact with hot exhaust gases.

Allow equipment to cool before touching.

Maintain at least 3 ft. (91.4 cm) of clearance on all sides to ensure adequate cooling.

Maintain at least 5 ft. (1.5 m) of clearance from combustible materials.

⚠ WARNING

Rapid retraction of the recoil cord will pull hand and arm towards the engine faster than you can let go. Broken bones, fractures, bruises or sprains could result. Unintentional startup can result in entanglement, traumatic amputation or laceration.

When starting engine, pull the recoil cord slowly until resistance is felt and then pull rapidly to avoid kickback.

DO NOT start or stop the engine with electrical devices plugged in and turned on.

⚠ CAUTION

Exceeding the generator's running capacity can damage the generator and/or electrical devices connected to it.

DO NOT overload the generator.







DO NOT tamper with the governed speed.

DO NOT modify the generator in any way.

IMPORTANT SAFETY INSTRUCTIONS

Safety Symbols



Some of the following symbols may be used on this product. Please study them and learn their meaning. Proper interpretation of these symbols will allow you to more safely operate the product.

SYMBOL	MEANING
	Read Operator's Manual. To reduce the risk of injury, user must read and understand operator's manual before using this product.
	Electric Shock. Failure to use in dry conditions and to observe safe practices can result in electric shock. Improper connections to a building can allow current to backfeed into utility lines, creating an electrocution hazard. A transfer switch must be used when connecting to a building.
	Fire/Explosion. Fuel and its vapors are extremely flammable and explosive. Fire or explosion can cause severe burns or death. Keep generator at least 5 feet (1.5m) from all objects to prevent combustion.
	Hot Surface. To reduce the risk of injury or damage, avoid contact with any hot surface.
	Open Flame Alert. Fuel and its vapors are extremely flammable and explosive. Keep fuel away from smoking, open flames, sparks, pilot lights, heat, and other ignition sources.
	Wet Conditions Alert. Do not expose to rain or use in damp locations.

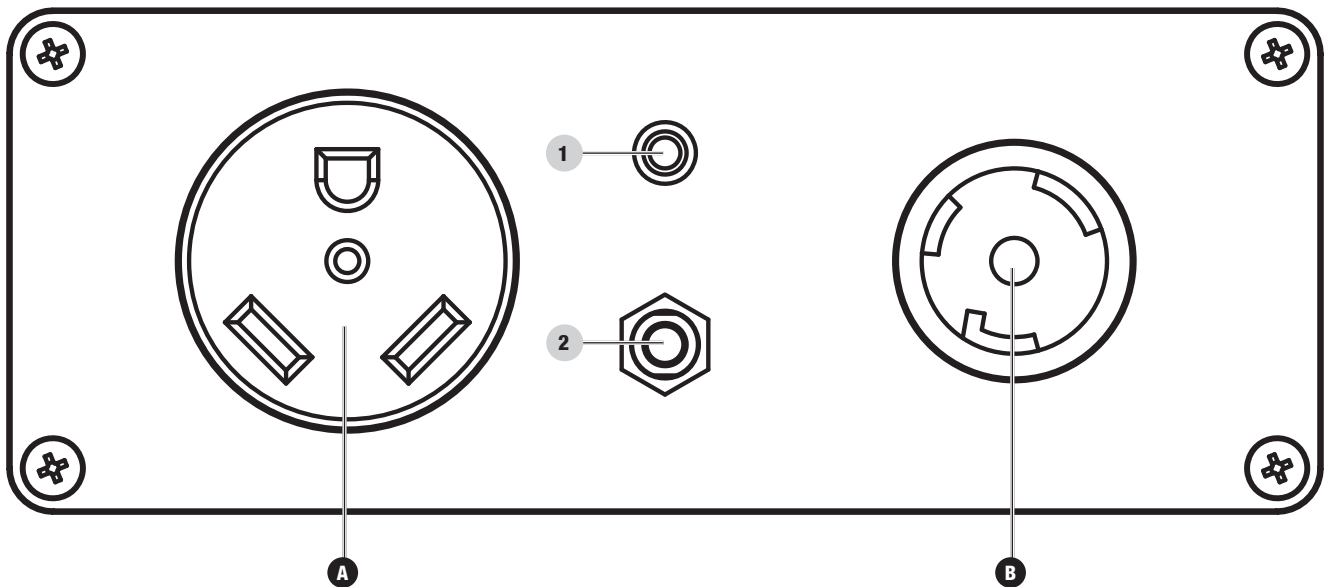
Control Panel



1. **Power Indicator** – Illuminates green when power is being supplied to the parallel kit.
2. **Circuit Breakers (Push Reset)** – Protects the generator against electrical overloads.

RECEPTACLES	
A	 <p>120V AC, 30A RV (NEMA TT-30R) May be used to supply electrical power for operation of 120 Volt AC, 30 Amp, single phase, 60 Hz electrical loads.</p>
B	 <p>120V AC, 30A Locking (NEMA L5-30R) May be used to supply electrical power for operation of 120 Volt AC, 30 Amp, single phase, 60 Hz electrical loads.</p>

ASSEMBLY AND OPERATION

This parallel kit is intended for use with Black Diamond and Champion Power Equipment inverters rated between 2000 and 3000 starting watts. Please refer to your inverter Operator's Manuals for safety rules, start up and shut down procedures, specifications, and troubleshooting.

The total output of this kit will depend on the rated wattage of the inverters connected to it. The maximum output of the parallel kit is the amperage rating of the circuit breakers.

Paralleling Two Inverters

⚠ WARNING

If not spaced apart, the exhaust heat from one unit may discolor or melt the plastic on the other unit. Always read your inverter Operator's Manuals before operating the inverters and parallel kit.

1. Ensure both inverters are turned off and all electrical loads are disconnected before installing parallel kit.
2. Align the inverters in a "V" configuration so the exhausts of each inverter are pointed well away from each other and the inverters are a minimum of 18 in. (46 cm) apart.

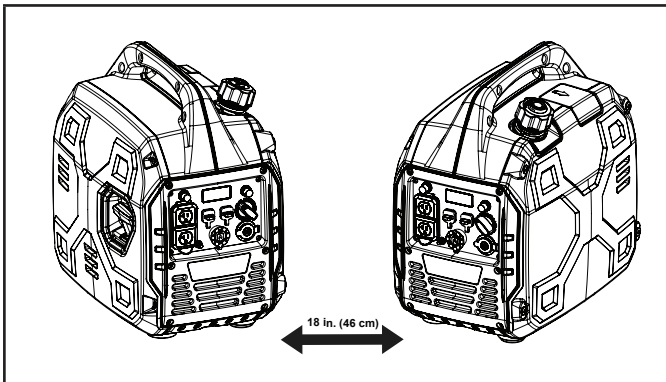

3. Mount the parallel kit to the inverter on the right of the "V" so that it rests on the side without the fuel cap.

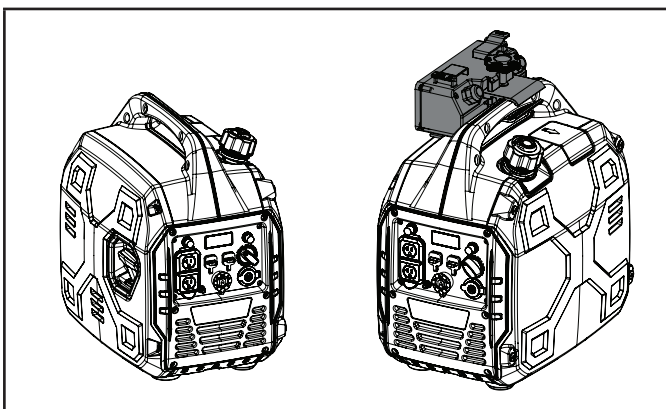

4. Place the bracket around the handle and tighten the fastening dial by turning clockwise until snug. Do not over tighten. You may need to loosen the fastening dial to get it around the handle before tightening.

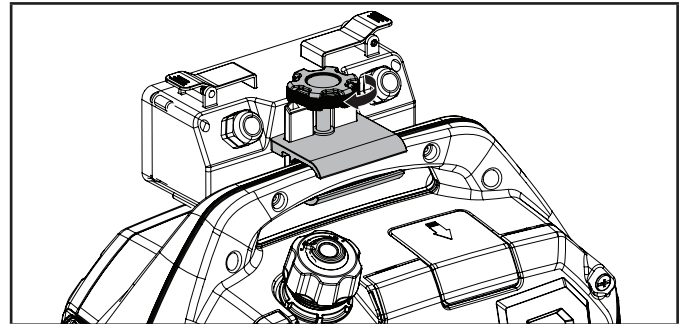

5. On each inverter, lift the parallel port covers, if applicable, and insert the RED power lead into the RED receptacle and the BLACK power lead into the BLACK receptacle.
6. On each inverter, connect the grounding wire to the grounding terminal on the inverter and secure the grounding lugs.
7. Start engine of both inverters according to inverter Operator's Manuals. Observe the green output indicator light on both inverter panels. The light may blink during start up and will turn solid green when loads may be connected.
8. Connect devices to the parallel kit and/or inverters up to the receptacles rated amperage. It is best to connect devices with the largest load first. Allow the engine to stabilize before plugging in more devices. Never exceed the specified capacity of the receptacle.
9. Follow the instructions in the inverter Operator's Manuals when turning off the inverters.

🗨 NOTICE

If the parallel kit has been overloaded and the circuit breaker has been tripped, reduce the load and press the parallel kit reset button to restore power.

🗨 NOTICE

This parallel kit is meant to parallel two ParaLINK compatible inverters together. Both inverters must have ParaLINK parallel receptacles as shown below:

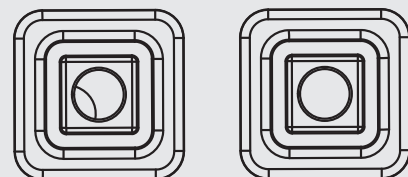

NOTICE

This unit should NOT be used to connect inverters with non-ParaLINK receptacles such as the style shown below:

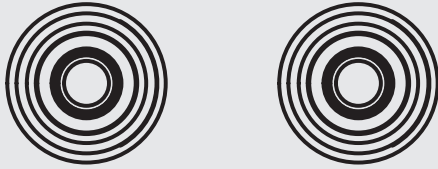

Adjusting the Anti-Vibration Wedges

There are two rubber wedges on the bottom of the parallel kit that can be removed or moved to create a friction fit wedge between the parallel kit and inverter. If, after tightening the fastener dial, your parallel kit is vibrating during operation slide the wedges toward the back of the parallel kit until snug to reduce vibration.

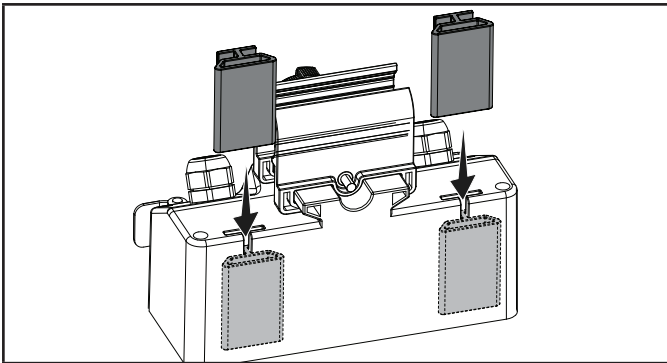

CABLE STORAGE

When not in use, neatly wrap the cables and use the spring loaded clips on top of the parallel kit to hold the cables in place.

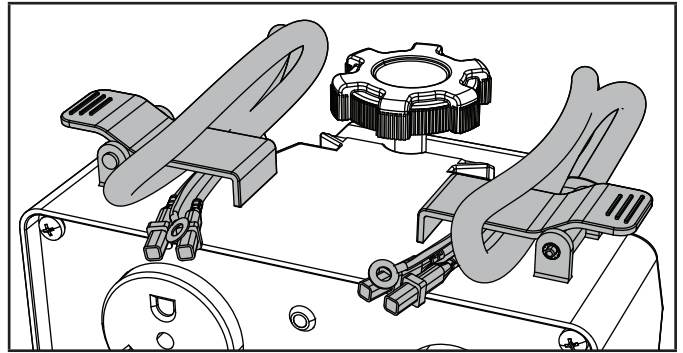

SPECIFICATIONS

Specifications

Model	BD201103
Volts AC	120
Frequency	60 Hz
Phase	Single
Weight	3.3 lb. (1.48 kg)
Length	8.6 in. (21.8 cm)
Width	6.4 in. (16.2 cm)
Height	5 in. (12.8 cm)

WARRANTY

CHAMPION POWER EQUIPMENT
1 YEAR LIMITED WARRANTY

Warranty Qualifications

To register your product for warranty and FREE lifetime call center technical support please visit:

<https://www.championpowerequipment.com/register>

To complete registration you will need to include a copy of the purchase receipt as proof of original purchase. Proof of purchase is required for warranty service. Please register within ten (10) days from date of purchase.

Repair/Replacement Warranty

CPE warrants to the original purchaser that the mechanical and electrical components will be free of defects in material and workmanship for a period of one year (parts and labor) from the original date of purchase and 90 days (parts and labor) for commercial and industrial use. Transportation charges on product submitted for repair or replacement under this warranty are the sole responsibility of the purchaser. This warranty only applies to the original purchaser and is not transferable.

Do Not Return The Unit To The Place Of Purchase

Contact CPE's Technical Service and CPE will troubleshoot any issue via phone or e-mail. If the problem is not corrected by this method, CPE will, at its option, authorize evaluation, repair or replacement of the defective part or component at a CPE Service Center. CPE will provide you with a case number for warranty service. Please keep it for future reference. Repairs or replacements without prior authorization, or at an unauthorized repair facility, will not be covered by this warranty.

Warranty Exclusions

This warranty does not cover the following repairs and equipment:

Normal Wear

Products with mechanical and electrical components need periodic parts and service to perform well. This warranty does not cover repair when normal use has exhausted the life of a part or the equipment as a whole.

Installation, Use and Maintenance

This warranty will not apply to parts and/or labor if the product is deemed to have been misused, neglected, involved in an accident, abused, loaded beyond the product's limits, modified, installed improperly or connected incorrectly to any electrical component. Normal maintenance is not covered by this warranty and is not required to be performed at a facility or by a person authorized by CPE.

Other Exclusions

This warranty excludes:

- Cosmetic defects such as paint, decals, etc.
- Wear items such as filter elements, o-rings, etc.
- Accessory parts such as starting batteries, and storage covers.
- Failures due to acts of God and other force majeure events beyond the manufacturer's control.
- Problems caused by parts that are not original Champion Power Equipment parts.

Limits of Implied Warranty and Consequential Damage

Champion Power Equipment disclaims any obligation to cover any loss of time, use of this product, freight, or any incidental or consequential claim by anyone from using this product. THIS WARRANTY IS IN LIEU OF ALL OTHER WARRANTIES, EXPRESS OR IMPLIED, INCLUDING WARRANTIES OF MERCHANTABILITY OR FITNESS FOR A PARTICULAR PURPOSE.

A unit provided as an exchange will be subject to the warranty of the original unit. The length of the warranty governing the exchanged unit will remain calculated by reference to the purchase date of the original unit.

This warranty gives you certain legal rights which may change from state to state or province to province. Your state or province may also have other rights you may be entitled to that are not listed within this warranty.

Contact Information

Address

Mid-States Distributing, LLC.
2800 Meacham Blvd.
Fort Worth, TX 76137 USA
www.black-diamond.com

Customer Service

Toll Free: 1-888-376-7375
info@black-diamond.com