

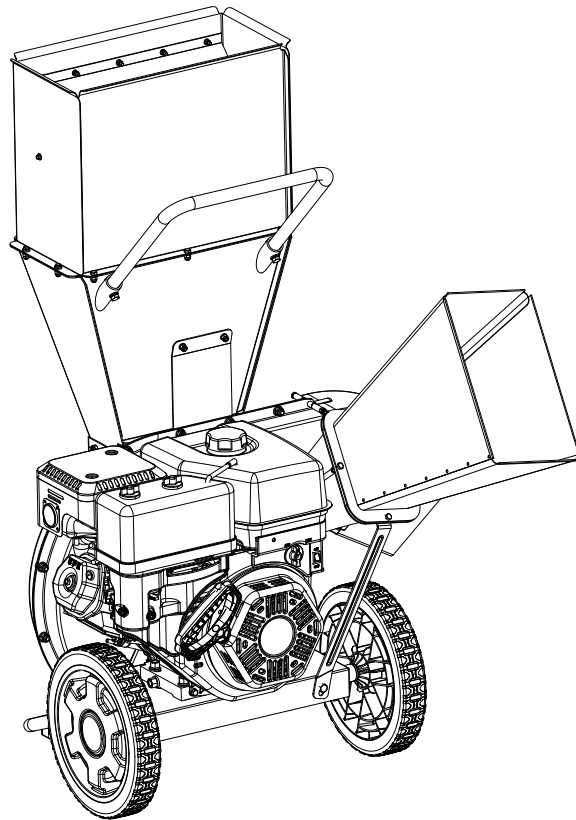

Champion Power Equipment, Inc.

**MODEL #91050**



## **PARTS INFORMATION**

**3 IN. CHIPPER SHREDDER**

**SERIAL NUMBER RANGE: Y2211180001+**



To order replacement parts please visit:  
**[shop.championpowerequipment.com](http://shop.championpowerequipment.com)**  
or call **1-877-338-0999**.

## **TABLE OF CONTENTS**

<b>Chipper Shredder Parts Diagram .....</b>	<b>3</b>
<b>Chipper Shredder Parts List .....</b>	<b>4</b>
<b>Engine Parts Diagram .....</b>	<b>6</b>
<b>Engine Parts List .....</b>	<b>7</b>
<b>Cylinder Head Diagram .....</b>	<b>10</b>
<b>Cylinder Head List .....</b>	<b>11</b>

# CHIPPER SHREDDER PARTS DIAGRAM

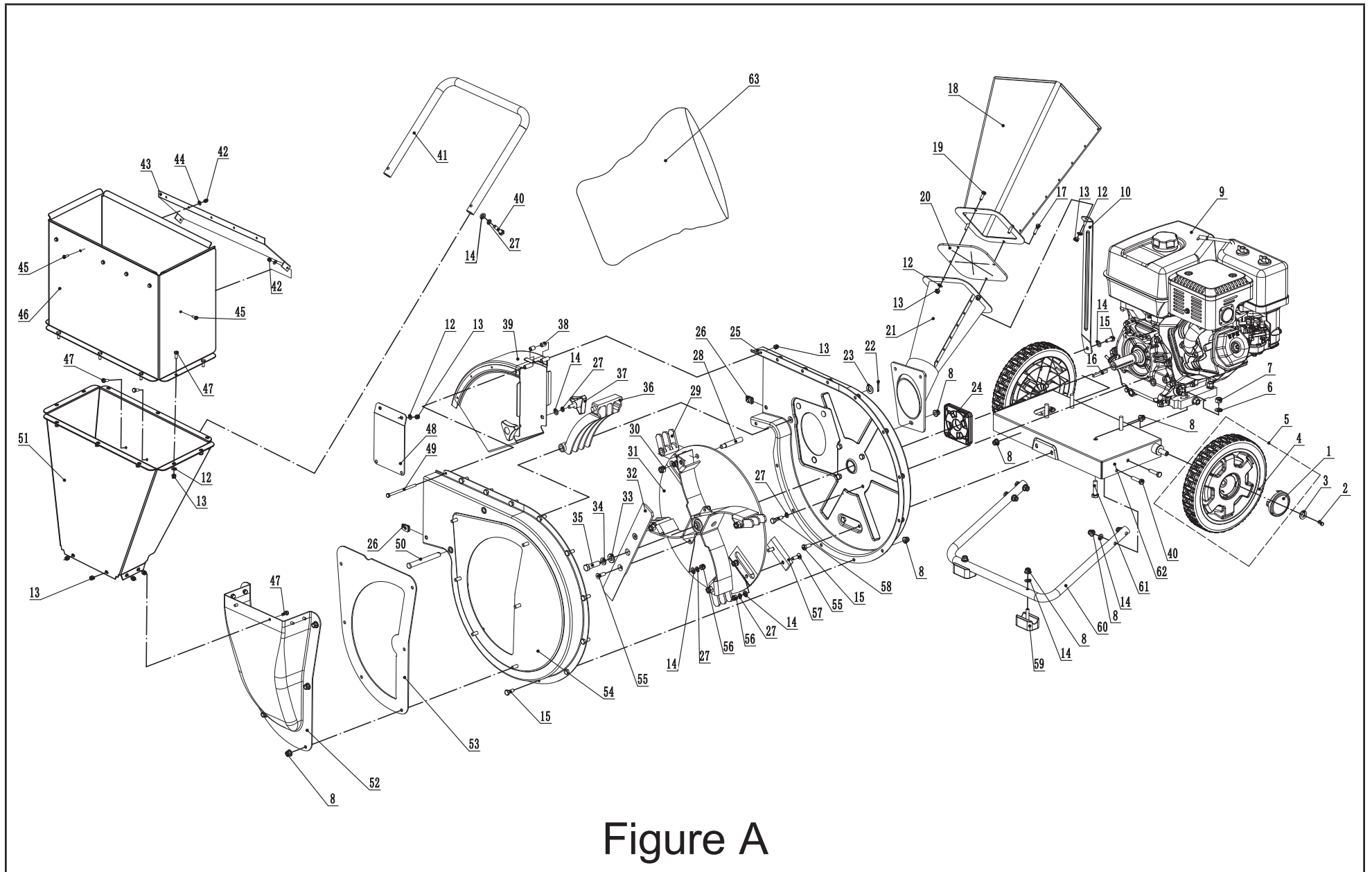

## CHIPPER SHREDDER PARTS LIST

#	Part Number	Description	Qty.
1	601.201702.00.48 S/N: < Y2202100216	Wheel Cap, Yellow	2
	254.201702.04.48 S/N: Y2204080001+		
2	1.91.3220 S/N: < Y2202100216	Bolt, M8 x 12	2
	1.16674.0812 S/N: Y2204080001+		
3	1.97.1.13 S/N: < Y2202100216	Washer, Ø15	2
	2.03.067 S/N: Y2204080001+		
4	601.201701.00 S/N: < Y2202100216	12 in. Wheel, Yellow	2
	254.201701.04.48 S/N: Y2204080001+		
5	254.201700.04.48	12 in. Wheel Assembly, Yellow	2
6	1.97.1.10	Washer, Ø10	4
7	1.6177.1.10	Nut, M10	4
8	1.6187.1.08	Flange Nut, M8	31
9	44.102	Engine	1
10	601.300027.01.2	Chute Support Bracket, Black	1
12	1.97.1.06	Washer, Ø6	22
13	1.6182.06	Lock Nut, M6	23
14	1.97.1.08	Washer, Ø8	17
15	1.16674.0820	Bolt, M8 x 20	16
16	2.14.002	Flat Key, 6.3 x 6.3 x 50	1
17	1.5789.0625	Flange Bolt, M6 x 25	1
18	601.300120.01.48	Upper Chipper Chute Assembly, Yellow	1
19	1.5789.0620	Flange Bolt, M6 x 20	3
20	601.300103.01	Block Rubber	1

#	Part Number	Description	Qty.
21	601.300110.01.48	Lower Chipper Chute Assembly, Yellow	1
22	1.91.3220	Cotter Pin, Ø3.2 x 20	1
23	1.97.1.13	Washer, Ø13	1
24	602.300601.01	Engine Plate Assembly	1
25	601.300200.00.2	Inner Flail Housing Assembly, Black	1
26	2.02.032	U Nut, M8	2
27	1.93.08	Lock Washer, Ø8	14
28	601.303005.00	Shoulder Pin	4
29	601.303003.00.2	Flail Blade, Black	4
30	1.6182.10	Lock Nut, M10	4
31	601.303100.00.2	Impeller Assembly, Black	1
32	601.303004.00	Shredder Blade	1
33	601.300024.00	Washer	1
34	2.03.063	Lock Washer, Ø12	1
35	2.08.136	Screw, 7/16 - 20UNF	1
36	601.300008.00.2	Shredder Screen, Black	1
37	601.300020.00	Knob, M8	2
38	601.300018.00	Hinge Spacer	2
39	601.300400.00.2	Chute Deflector Assembly, Black	1
40	1.5789.0835	Flange Bolt, M8 x 35	6
41	601.301703.00.2	Hopper Handle, Black	1
42	1.6182.05	Lock Nut, M5	7
43	601.301704.00.48	Baffle, Yellow	1
44	1.97.1.05	Washer, Ø5	7
45	1.16674.0512.2	Bolt, M5 x 12	7
46	601.301709.00.48 S/N: < Y2209220432	Upper Hopper Front Assembly, Yellow	1
	601.301730.00.48 S/N: Y2211180001+		
47	1.5789.0615	Flange Bolt, M6 x 15	22

#	Part Number	Description	Qty.
48	601.300014.00.2	Hopper Support Bracket, Black	1
49	1.5782.06100	Bolt, M6 x 100	1
50	601.300022.00	Clevis Pin	1
51	601.301702.00.48 S/N: < Y2209220432	Lower Hopper Front Assembly, Yellow	1
	601.301720.00.48 S/N: Y2211180001+		
52	601.300013.00.2	Inlet Guide, Black	1
53	601.300007.00.2	Shredder Plate, Black	1
54	601.300500.00.2	Outer Flail Housing Assembly, Black	1
55	1.70.3.0825	Machine Screw, M8 x 25	6
56	1.6182.08	Lock Nut, M8	6
57	601.303002.00	Chipper Blade	2
58	2.08.137	Bolt , 5/16 - 24UNF	4
59	601.300021.00	Rubber Cushion	2
60	601.300011.00.2	Tube Support, Black	1
61	1.5783.1040	Bolt, M10 x 40	4
62	601.300900.00.1 S/N: < Y2202100216	Frame Assembly, Black	1
	601.300900.01.2 S/N: Y2204080001+		
63	9.1400.001	Collection Bag	1

# ENGINE PARTS DIAGRAM

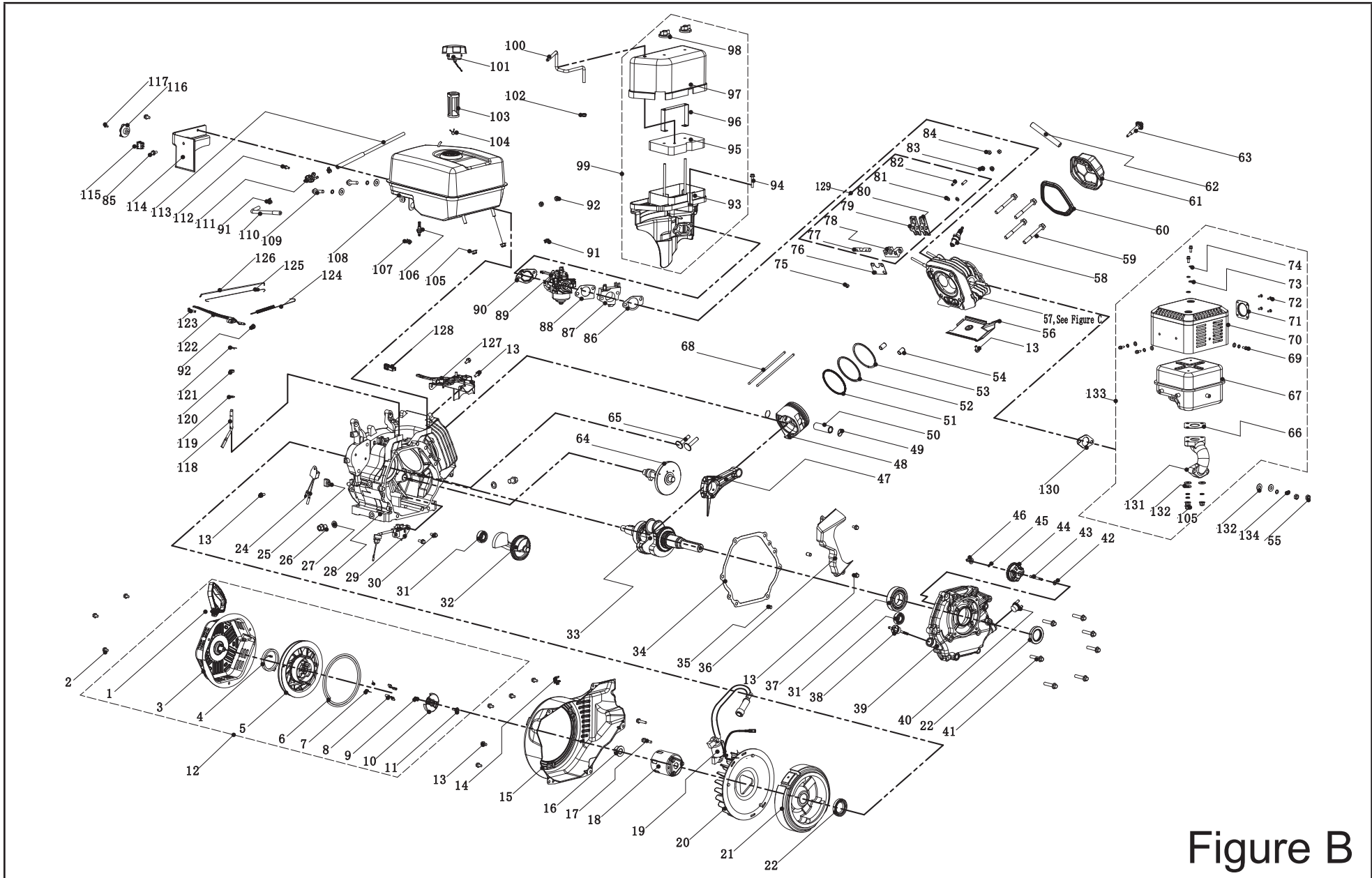

Figure B

**ENGINE PARTS LIST**

#	Part Number	Description	Qty.
1	23.061006.01	Recoil Handle, Big	1
2	1.5789.0608	Flange Bolt M6 x 8	3
3	46.061100.00.2	Recoil Starter Cover, Black	1
4	45.060005.00	Recoil Starter Spring	1
5	45.061102.00	Recoil Starter Reel	1
6	2.10.003.1	Rope Ø4 x 1550, Black	1
7	45.060003.00	Spring, Ratchet	2
8	45.060002.00	Starter Ratchet, Iron	2
9	45.060009.00	Spring, Ratchet Guide	1
10	45.060007.00	Ratchet Guide	1
11	45.060008.00	Screw, Ratchet Guide	1
12	46.061000.01	Recoil Assembly	1
13	1.5789.0612	Flange Bolt M6 x 12	11
14	2.05.003	Clamp Ø11.5 x 10	1
15	46.080100.00.48	Fan Cover, Yellow	1
16	2.02.007	Nut M16 x 1.5	1
17	1.5789.0629	Flange Bolt M6 x 29	2
18	45.060001.00	Pulley, Starter	1
19	46.123000.01	Ignition Coil	1
20	45.080001.00	Cooling Fan	1
21	46.120100.03	Flywheel, Manual Start EPA	1
22	2.11.007	Oil Seal Ø35 x Ø52 x 8	2
23	46.131017.01	Standard Main Jet	1
	46.131017.01.01	Altitude Main Jet	/
24	21.120400.00	Diode Assembly	1
25	45.030032.00	Sheath, Wire	1
26	2.08.039	Drain Bolt M12 x 1.5 x 15	2
27	2.03.023	Washer Ø12.5 x Ø20 x 2	2
28	46.030100.00	Crankcase	1
29	45.127000.02	Oil Level Sensor	1

#	Part Number	Description	Qty.
30	1.5789.0615	Flange Bolt M6 x 15	2
31	1.276.6202	Bearing 6202	2
32	47.050006.00	Weight Balancer	1
33	45.050100.09	Crankshaft	1
34	46.030008.00	Gasket, Crankcase Cover	1
35	2.04.001	Dowel Pin Ø9 x 14	2
36	46.080600.00	Air Guide, Right Side	1
37	1.276.6207	Bearing 6207	1
38	46.031000.00.48	Oil Dipstick Assembly, Yellow	1
39	45.030007.01	Cover, Crankcase	1
40	22.031000.01.48	Oil Filler Cap, Yellow	1
41	1.5789.0840	Flange Bolt M8 x 40	7
42	2.03.021.1	Washer Ø6.4 x Ø13 x 1, Black	1
43	45.110013.00	Shaft, Governor Gear	1
44	45.110100.00	Governor Gear	1
45	21.110011.00	Clip, Governor Gear	1
46	45.110012.00	Bushing, Governor Gear	1
47	47.050200.00	Connecting Rod	1
48	46.050005.01	Piston	1
49	2.09.004	Circlip Ø21 x Ø1	2
50	45.050003.00	Pin, Piston	1
51	46.050303.01	Ring, Oil	1
52	46.050302.01	Ring, Second Piston	1
53	46.050301.01	Ring, First Piston	1
54	2.04.004	Dowel Pin Ø12 x 20	2
55	1.6175.08	Nut M8	2
56	46.080400.00	Air Guide, Lower	1
57	46.010000.00	Cylinder Head Assembly, See Figure C	1
58	2.15.002(F6RTC)	Spark Plug, F6RTC	1
59	2.08.014	Flange Bolt M10 x 80	4

#	Part Number	Description	Qty.
60	46.020002.00	Gasket, Cylinder Head Cover	1
61	46.021000.00	Cylinder Head Cover	1
62	45.020001.02	Breather Tube	1
63	45.020100.00	Bolt, Cylinder Head Cover	1
64	46.041000.00	Camshaft	1
65	45.040013.00	Valve Lifter	2
66	46.101002.05	Washer, Muffler	1
67	46.101100.05	Muffler	1
68	46.040005.00	Push Rod	2
69	1.16674.0510	Flange Bolt M5 x 10	5
70	46.101202.05	Muffler Protector	1
71	46.101300.05	Muffler Screen	1
72	1.818.046	Screw M4 x 6	4
73	1.848.05	Washer Ø5	5
74	1.859.05	Lock Washer Ø5	5
75	45.040008.00	Rotator, Exhaust Valve	1
76	46.040004.00	Guide Plate, Push Rod	1
77	46.040016.00	Shaft, Rocker Arm	1
78	46.040201.00	Retainer, Rocker Arm	1
79	46.040009.00	Rocker Arm, Intake Valve	1
80	46.040018.00	Rocker Arm, Exhaust Valve	1
81	1.971.06	Washer Ø6	2
82	22.040012.00	Screw, Valve Adjustment	2
83	1.6177.1.06	Flange Lock Nut M6	2
84	21.040021.00	Lock Nut M6 x 0.5	2
85	1.5789.0612.3	Flange Bolt M6 x 12	2
86	46.130002.20	Gasket, Insulator	1
87	45.130001.01	Insulator, Carburetor	1
88	46.130003.00	Gasket, Carburetor	1
89	46.131000.01	Carburetor	1
90	45.130004.00	Gasket, Air Cleaner	1
91	2.06.007	Clip Ø8 x b6	3

#	Part Number	Description	Qty.
92	1.6177.06	Flange Nut M6	3
93	46.091100.01	Base, Air Cleaner	1
94	1.5789.0633	Flange Bolt M6 x 33	1
95	46.091003.08	Element, Air Cleaner	1
96	46.091102.01	Supporter, Air Cleaner	1
97	46.091200.02	Cover, Air Cleaner	1
98	46.091600.01	Screw cap, Air Cleaner Cover	2
99	46.091000.08	Air Cleaner Assembly	1
100	46.070014.01	Pipe, Fuel Tank To Air Cleaner	1
101	24.070100.02	Fuel Tank Cap	1
102	2.12.001	Buffer Ø7.5 x 7.5	1
103	46.070300.00	Fuel Filter Component, Large	1
104	2.06.006	Clamp Ø7 x Ø1	1
105	1.6187.1.08	Nut M8	5
106	21.070600.03	Joint, Fuel Pipe	1
107	2.06.016	Clamp Ø8.7 x b8	1
108	46.071000.01	Fuel Tank	1
109	1.5789.0832	Flange Bolt M8 x 32	2
110	46.070011.00	Pipe, Fuel Tank To Fuel Valve	1
111	24.070400.00	Fuel Valve	1
112	1.16674.0512.2	Flange Bolt M5 x 12	1
113	46.070011.01	Pipe, Fuel Valve To Carburetor	1
114	46.070010.00	Fuel Tank Veil	1
115	5.1010.003.3	Ignition Switch, Red	1
116	24.070001.00	Fuel Valve Knob	1
117	1.818.0412	Bolt M4 x 12	1
118	45.110001.00	Shaft, Governor Arm	1
119	2.03.019	Washer Ø8.2 x Ø17 x 0.8	1
120	2.11.006	Oil Seal Ø7 x Ø14 x 5	1
121	45.110008.00	Pin, Shaft	1
122	45.110003.00	Arm, Governor	1
123	2.08.040	Bolt M6 x 21, Governor Arm	1

#	Part Number	Description	Qty.
124	45.110007.00	Spring, Governor	1
125	45.110005.00	Spring, Throttle Return	1
126	45.110006.00	Rod, Governor	1
127	46.080300.00	Air Guide, Upper	1
128	24.111008.01	Sheath, Grip	1
129	46.040200.00	Rocker Arm Assembly	1
130	46.100001.07	Gasket, Exhaust Pipe	1
131	46.101001.05	Exhaust Pipe	1
132	1.848.08	Washer Ø8	7
133	46.101000.05	Muffler Assembly	1
134	1.93.08	Lock Washer Ø8	7

# CYLINDER HEAD DIAGRAM

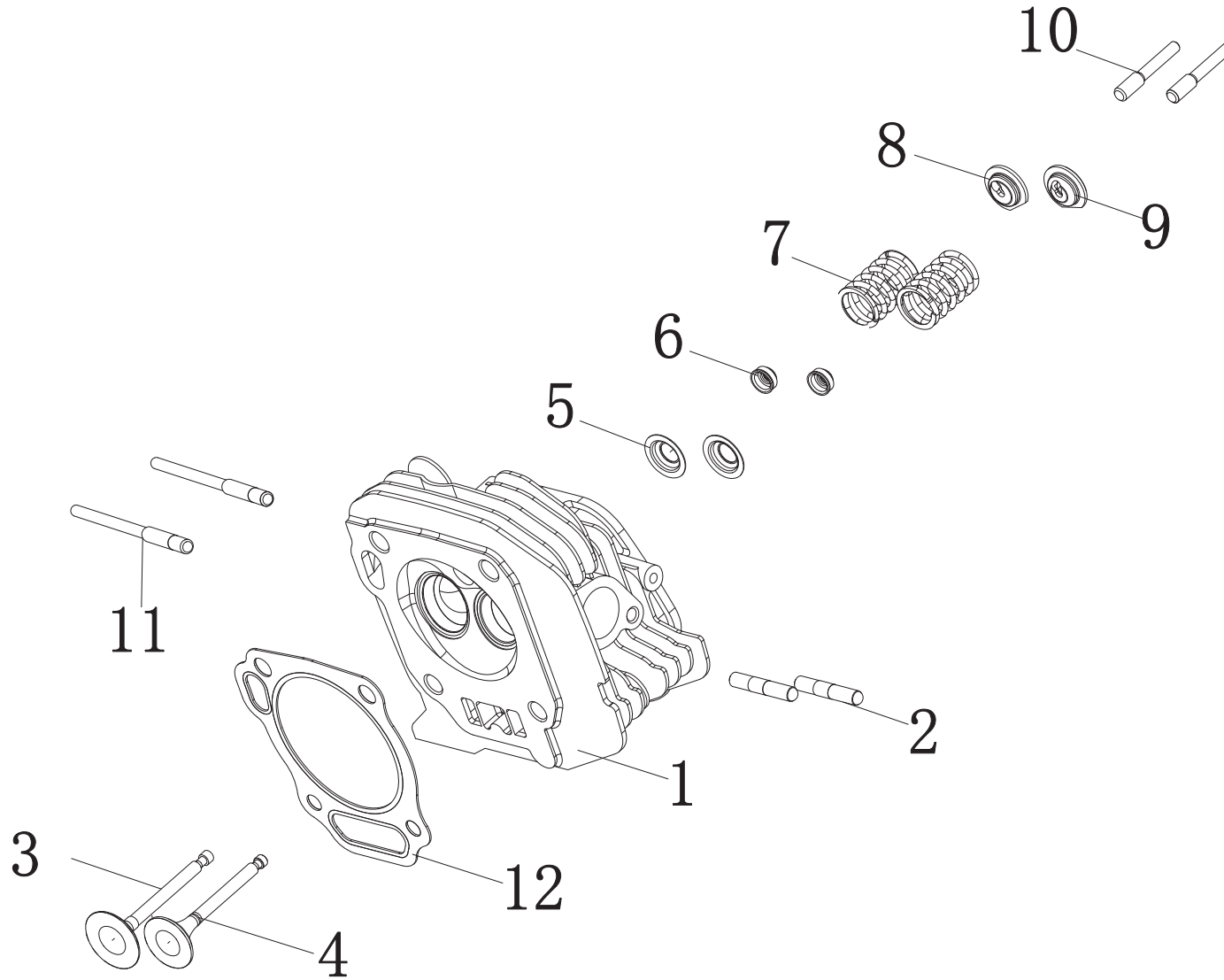

Figure C

**CYLINDER HEAD LIST**

#	Part Number	Description	Qty.
1	46.010100.00	Cylinder Head	1
2	2.01.005	Stud Bolt M8 x 49	2
3	45.040002.00	Intake Valve	1
4	45.040006.00	Exhaust Valve	1
5	45.040015.00	Retainer, Valve Spring, Down	2
6	45.040017.00	Oil Seal, Valve	2
7	45.040003.00	Spring, Valve	2
8	45.040001.00	Retainer, Intake Valve Spring, Up	1
9	45.040007.00	Retainer, Exhaust Valve Spring, Up	1
10	23.040010.00	Bolt, Rocker Arm	2
11	2.01.007	Stud Bolt M6 x M8 x 130	2
12	46.030009.00	Gasket, Cylinder Head	1