

CHAMPION

POWER EQUIPMENT

TM-MC

OWNER'S MANUAL



3 in. (7.6 cm) Chipper-Shredder



MODEL NUMBER

91050

SAVE THESE INSTRUCTIONS
Important Safety Instructions
are included in this manual.

MADE IN CHINA
REV 91050-20190114

12039 Smith Ave.
Santa Fe Springs, CA 90670
USA / 1-877-338-0999
www.championpowerequipment.com

AN IMPORTANT MESSAGE ABOUT TEMPERATURE:

Your Champion Power Equipment product is designed and rated for continuous operation at ambient temperatures up to 40°C (104°F). When your product is needed your product may be operated at temperatures ranging from -15°C (5°F) to 50°C (122°F) for short periods. If the product is exposed to temperatures outside this range during storage, it should be brought back within this range before operation. In any event, the product must always be operated outdoors, in a well-ventilated area and away from doors, windows and other vents.

Have questions or need assistance?

Do not return this product to the store!

WE ARE HERE TO HELP!

Visit our website:

www.championpowerequipment.com

for more info:

- Product Info & Updates
- Tech Bulletins
- Frequently Asked Questions
- Product Registration

– or –

Call our Customer Care Team Toll-Free at:

1-877-338-0999

Parts Ordering:

Mon – Fri 8:30 AM – 5:00 PM (PST/PDT)

Toll Free: 1-877-338-0999

*We are always working to improve our products. Therefore, the enclosed product may differ slightly from the image on the cover.

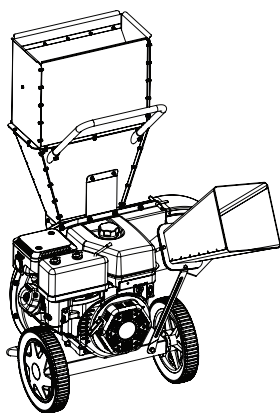

3 in. (7.6 cm)

Chipper-Shredder

TABLE OF CONTENTS

Introduction	1	Maintenance and Storage	18
Manual Conventions	2	Engine Maintenance	18
Safety Rules	3	Oil	18
Training	5	Spark Plugs	18
Preparation	5	Air Filter	19
Operation	6	Chipper-shredder Maintenance	19
Maintenance and Storage	6	Cleaning	19
Controls and Features	7	Flail Housing and Impeller Cleaning	19
Chipper-shredder	7	Blade Sharpening	20
Parts Included	8	Maintenance Schedule	21
Assembly	9	Storage	21
Unpacking	9	Chipper-shredder Storage	21
1) Install the Shredder Chute	9	Engine Stored for Less than 30 Days	21
2) Install the Handle	9	Engines Stored for Over 30 Days	21
3) Install the Chipper Chute	9	Specifications	22
4) Install the Chute Deflector	10	Chipper-shredder Specifications	22
Collection Bag	10	Engine Specifications	22
Add Engine Oil	11	Fuel	22
Add Engine Fuel	12	Oil	22
Operation	13	Spark Plugs	22
Chipper-shredder Location	13	Maintenance Valve Clearance	22
Work Area	13	Parts Diagram	23
Before Each Use Inspect the Chipper-shredder	14	Parts List	24
Starting the Engine	14	Engine Parts Diagram	25
Chipper-shredder Operation	15	Engine Parts List	26
Chipping and Shredding Tips	16	Troubleshooting	27
Chipping	16		
Shredding	16		
Clearing the Shredding Chute	16		
Emptying the Collection Bag	17		
Stopping the Engine	17		
Operation at High Altitude	17		

INTRODUCTION

Introduction

Congratulations on your purchase of a Champion Power Equipment product. Champion Power Equipment and Champion Engine Technology designs, builds, and supports all of our products to strict specifications and guidelines. With proper product knowledge, safe use, and regular maintenance, this product should bring years of satisfying service.

Every effort has been made to ensure the accuracy and completeness of the information in this manual, and we reserve the right to change, alter and/or improve the product and this document at any time without prior notice.

Since CPE/CET highly value how our products are designed, manufactured, operated and are serviced, and also highly value your safety and the safety of others, we would like you to take the time to review this product manual and other product materials thoroughly and be fully aware and knowledgeable of the assembly, operation, dangers and maintenance of the product before use. Fully familiarize yourself, and make sure others who plan on operating the product fully familiarize themselves too, with the proper safety and operation procedures before each use. Please always exercise common sense and always err on the side of caution when operating the product to ensure no accidents, property damage, or injury occurs. We want you to continue to use and be satisfied with your CPE/CET product for years to come.

Record the model and serial numbers as well as date and place of purchase for future reference. Have this information available when ordering parts and when making technical or warranty inquiries.

1-877-338-0999
Model Number
91050
Serial Number
Date of Purchase
Purchase Location
For Oil Type see 'Add Engine Oil' section. For Fuel Type see 'Add Fuel' section.

This manual uses the following symbols to help differentiate between different kinds of information. The safety symbol is used with a key word to alert you to potential hazards in operating and owning power equipment.

Follow all safety messages to avoid or reduce the risk of serious injury or death.

 **DANGER**

DANGER indicates an imminently hazardous situation which, if not avoided, **will** result in death or serious injury.

 **WARNING**

WARNING indicates a potentially hazardous situation which, if not avoided, **could** result in death or serious injury.

 **CAUTION**

CAUTION indicates a potentially hazardous situation which, if not avoided, **may** result in minor or moderate injury.

CAUTION

CAUTION used without the safety alert symbol indicates a potentially hazardous situation which, if not avoided, **may** result in property damage.

 **NOTE**

If you have questions regarding your chipper-shredder, we can help. Please call our help line at **1-877-338-0999**.

SAFETY RULES

DANGER

Read this manual thoroughly, and understand all safety rules before operating the chipper-shredder. Become familiar with the product and know how to stop the product immediately if needed. Failure to follow safety instructions and familiarize one's self with product operation could result in serious property damage, injury or death.

DANGER

Always disconnect the spark plug wire during times of inactivity, cleaning and maintenance. This will prevent any accidental start up that may cause damage or injury.

DANGER

Engine exhaust contains carbon monoxide, a colourless, odourless, poison gas. Breathing carbon monoxide will cause nausea, dizziness, fainting or death. If you start to feel dizzy or weak, get to fresh air immediately.

Run the motor outdoors only in a well ventilated area. DO NOT operate the engine inside any buildings or enclosures.
DO NOT allow exhaust fumes to enter a confined area through windows, doors, vents or other openings. **DANGER CARBON MONOXIDE**, using an engine indoors **CAN KILL YOU IN MINUTES**.

DANGER

Hands, feet, hair, clothing and / or accessories can be caught in moving rotating parts and cause a traumatic amputation or severe laceration.

Keep hands and feet away from rotating parts. Tie up long hair and remove jewellery. Operate equipment with guards in place. DO NOT wear loose-fitting clothing, dangling drawstrings or items that could become caught.

DANGER

Sparks can result in fire or electrical shock.

When servicing the engine:

Disconnect the spark plug wire and place it where it cannot contact the plug. DO NOT check for spark with the plug removed. Use only approved spark plug testers.

WARNING

Running engines produce heat. Severe burns can occur on contact. Combustible material can catch fire on contact.

DO NOT touch hot surfaces. Avoid contact with hot exhaust gases. Allow equipment to cool before touching. Maintain at least 3 ft. (91.4 cm) of clearance on all sides to ensure adequate cooling. Maintain at least 5 ft. (1.5 m) of clearance from combustible materials.

WARNING

Child, Pet and Bystander Hazard

Do not allow children, pets or bystanders near the work area or location of the chipper-shredder. This can create potential distractions and safety hazards. Accidents, damage and injury could occur. A minimum distance of 75 ft. (22.9 m) from the chipper-shredder is recommended. Projectiles can also fly haphazardly in the work area. Only a qualified adult with complete working knowledge of the product and safety rules should operate the chipper-shredder and be in the work area.

 DANGER

Fuel and fuel vapours are highly flammable and extremely explosive.

Fire or explosion can cause severe burns or death. Unintentional startup can result in entanglement, traumatic amputation or laceration.

When adding or removing fuel:

Turn the engine off and let it cool for at least two minutes before removing the fuel cap. Loosen the cap slowly to relieve pressure in the tank. Only fill or drain fuel outdoors in a well-ventilated area. DO NOT pump gas directly into the chipper-shredder at the gas station. Use an approved container to transfer the fuel to the chipper-shredder.

DO NOT overfill the fuel tank.

Always keep fuel away from sparks, open flames, pilot lights, heat and other sources of ignition.

DO NOT light or smoke cigarettes.

When starting the engine:

DO NOT attempt to start a damaged engine. Make certain that the gas cap, air filter, spark plug, fuel lines and exhaust system are properly in place. Allow spilled fuel to evaporate fully before attempting to start the engine. Make certain that the chipper-shredder is resting firmly on level ground.

When operating the chipper-shredder:

DO NOT move or tip the chipper-shredder during operation.

DO NOT tip the chipper-shredder or allow fuel or oil to spill.

When transporting or servicing the chipper-shredder:

Make certain that the fuel shutoff valve is in the off position and the fuel tank is empty. Disconnect the spark plug wire.

When storing the chipper-shredder:

Store away from sparks, open flames, pilot lights, heat and other sources of ignition.

 WARNING

Keep Operator Work Zone Clear

Keep work zone clear of debris while working to ensure safe footing.

 WARNING

Projectile Hazard

Pieces of debris may be ejected from the chipper-shredder while operating. **Be alert.**

 DANGER

Always wear proper clothing and safety gear.

Close fitting clothing and safety approved eye protection must be worn at all times around the chipper-shredder. Wear boots or sturdy shoes that will improve footing around slippery surfaces.

 WARNING

Rapid retraction of the starter cord will pull hand and arm towards the engine faster than you can let go. Unintentional startup can result in entanglement, traumatic amputation or laceration. Broken bones, fractures, bruises or sprains could result.

When starting engine, pull the starter cord slowly until resistance is felt and then pull rapidly to avoid kickback.

 CAUTION

Improper treatment or use of the chipper-shredder can damage it, shorten its life and void your warranty.

Use the chipper-shredder only for intended uses. Operate only on level surfaces. DO NOT expose chipper-shredder to excessive moisture, dust, or dirt. DO NOT allow any material to block the cooling slots.

DO NOT use the engine if:

- Equipment sparks, smokes or emits flames
- Equipment vibrates excessively
- Equipment makes unusual sounds
- Equipment is damaged

SAFETY RULES

Training

1. Read the Operator's Manual completely before attempting to use this chipper-shredder.
2. Do not allow anyone to operate your chipper-shredder who has not read the Operator's Manual or has not been instructed on the safe use of the chipper-shredder.
3. Never allow children or untrained adults to operate this machine.
4. Many accidents occur when more than one (1) person operates the chipper-shredder. If a helper is assisting, never actuate controls until helper is clear of the area.
5. Never allow anyone to ride on the machine.
6. Never transport cargo on the chipper-shredder.
7. Projectiles can exit the chipper-shredder at high velocities. Therefore, the following instructions should be heeded at all times.
 - a. Never operate the unit on hardened ground, such as asphalt or concrete.
 - b. Never operate the unit close to any buildings or walls.
 - c. Do not allow children, pets, bystanders, and assistants to be within 75 ft. (22.9 m) of the unit during operation.
 - d. Do not lean directly over any chute, entry or exit, during operation.
8. Keep the operator zone and adjacent area clear for safe, secure footing.
9. If your chipper-shredder is equipped with an internal-combustion engine and intended for use near any unimproved forest, brush, or grass covered land, the engine exhaust should be equipped with a spark arrestor. Make sure you comply with local, state, and federal codes. Take appropriate fire-fighting equipment with you.
10. Chipper-shredders should be used only for chipping branches 3 in. (7.6 cm) or less in diameters or shredding vegetation with small diameter branches. Do not use for other purposes.
11. Always make sure the spark plug wire is disconnected from the engine when not in use, and before cleaning or maintenance.

Preparation

1. Be thoroughly familiar with all controls and with proper use of the equipment.
2. Make sure the spark plug wire is disconnected until operation.
3. Safety Gear:
 - a. Always wear safety shoes or heavy boots when operating the machine.
 - b. Always wear safety glasses or goggles when operating the machine.
 - c. Never wear jewelry or loose-fitting clothing that might become entangled in moving or rotating parts of the machine.
 - d. Always wear hearing protection.
 - e. Tie back long hair or anything that will dangle and may get entangled.
4. Inspection:
 - a. Make sure the spark plug wire has been fully removed and the unit is grounded.
 - b. Make sure the chutes, chambers, and intakes/exits are all clean and free of any debris.
 - c. Make sure the work area is clean and has no obstacles or distractions.
 - d. Make sure all connections and parts are secure and undamaged.
 - e. Make sure collection bag is fully connected and secure.
 - f. Make sure material to be chipped is less than 3 in. (7.6 cm) in diameter. Branches to be chipped can be pruned down.
 - g. Make sure material to be chipped or shredded is not damp or wet.
5. Check to make sure the chipper-shredder is on a level surface that is not asphalt, concrete or harden ground. Block the wheels and ensure support leg is secure to prevent unintended movement of the chipper-shredder during operation.
 - a. Always operate the chipper shredder from the manufacturer's indicated operator zone.
6. Fuel:
 - a. Use an approved fuel container.
 - b. Never add fuel to a running or hot engine.
 - c. Fill fuel tank outdoors with extreme care. Never fill fuel tank indoors.
 - d. Replace gasoline cap securely and clean up any spilled fuel.

Operation

1. Before starting this chipper-shredder, review all safety rules. Failure to follow these rules may result in serious injury to the operator or bystanders.
2. Be sure to confirm all connections are tight before each use. It is possible for connections to vibrate loose over time.
3. Never leave the machine unattended with the power source operating.
4. Never operate the machine when under the influence of alcohol, drugs or medication.
5. The machine owner should instruct all operators in safe chipper-shredder operation.
6. Always operate the chipper-shredder with all safety equipment in place and all controls properly adjusted for safe operation.
7. Always operate the chipper-shredder at manufacturer's recommended speed.
8. Always keep hands and feet clear of moving parts.
9. When loading the chipper-shredder, never place your hands inside or on the sides of the chutes, chambers, or intake. Never place your hands or any part of your body between the material and any part of the chipper-shredder.
 - a. Never attempt to chip more than one (1) branch at a time, this may cause the chute, chamber or intake to become clogged.
 - b. Never attempt to use your hand, foot or any body part to unclog the chipper-shredder.
 - c. Only attempt to unclog with a small diameter stick that can get chipped.
 - d. If a major clog occurs; turn the fuel valve off and let the unit run until dry, turn off the engine, let the unit cool down, unplug the spark plug wire and take apart the unit to see where the clog has occurred. Remove clog before further operation.
10. Only chip branches 3 in. (7.6 cm) or less in diameter.
11. Only shred dry or slightly damp material. Never attempt to shred material that is wet, as this may cause clogging to occur.
12. Use only your hand to operate the chipper-shredder controls.
13. Do not refuel the engine until it has cooled for several minutes.

Maintenance and Storage

1. Always shut off the power source and disconnect the spark plug wire and ground the engine, while repairing or adjusting the unit.
2. Clean debris, shrubbery and chaff from the engine cylinder, cylinder head fins, blower house rotation screen, and muffler areas. If the engine is equipped with a spark arrestor muffler, clean and inspect it regularly (follow manufacturer's service instructions). Replace, if damaged.
3. Never store the unit with fuel in the tank. Fumes might reach an open flame spark. Allow the engine to cool before storing in any enclosure.
4. Clear debris from moveable parts, but only when the engine is off, the fuel valve is in the "OFF" position, and the spark plug wire is disconnected.
5. Check to be sure all nuts and bolts are tight to assure the equipment is in safe working condition.

CONTROLS AND FEATURES

Read this owner's manual before operating your chipper-shredder. Familiarize yourself with the location and function of the controls and features. Save this manual for future reference.

Chipper-shredder

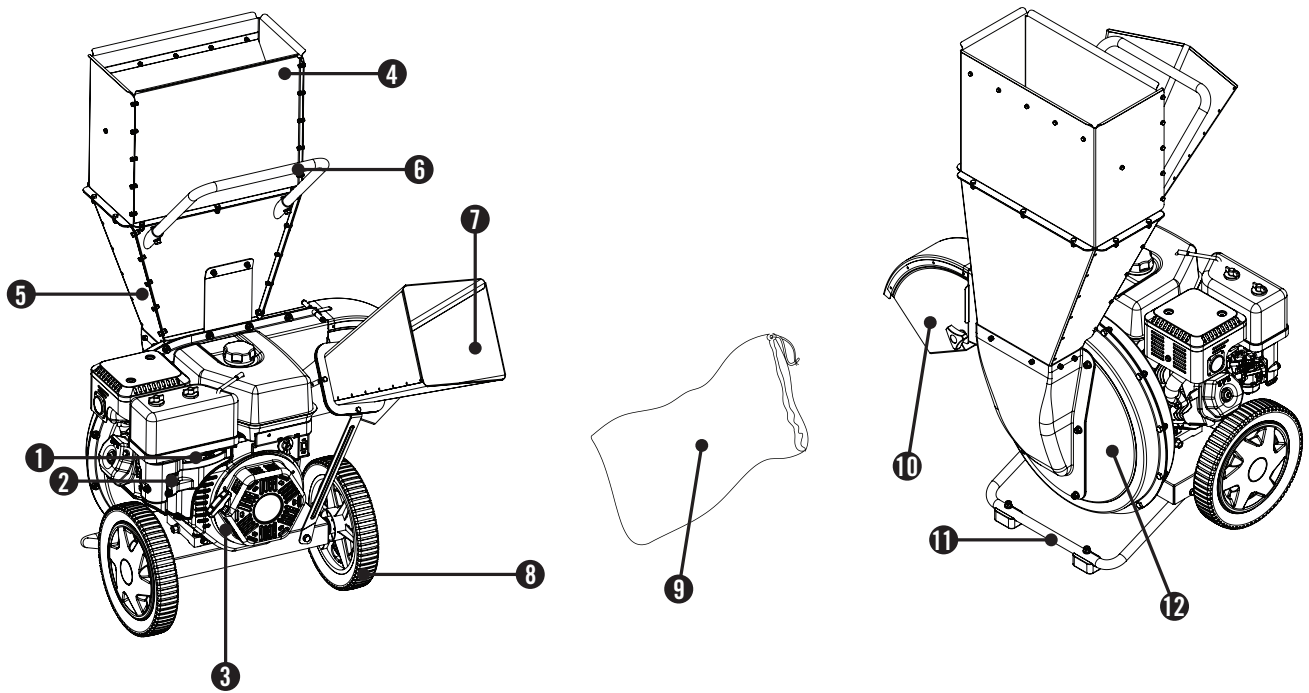

- (1) **Throttle**
- (2) **Choke**
- (3) **Engine** – 338cc, OHV, 4-stroke, air cooled.
- (4) **Upper Shredder Chute** – place shreddable material in this chute.
- (5) **Lower Shredder Chute**
- (6) **Handle**
- (7) **Chipper Chute** – place chippable material in this chute.
- (8) **Wheels** – 12 in. (30.5 cm) never flat.
- (9) **Collection Bag** – attach to chute deflector to collect material.
- (10) **Chute Deflector** – chipped or shredded material will exit from this.
- (11) **Support Leg with Vibration Mounts** – used to help stabilize the unit.
- (12) **Flail Housing** – housing for chipper-shredder blades.

Parts Included

Your 91050 gasoline powered chipper-shredder ships with the following parts:

- Collection Bag - 2 Bushel (70 L) Capacity 1
- Oil Funnel 1
- Spark Plug Socket 1

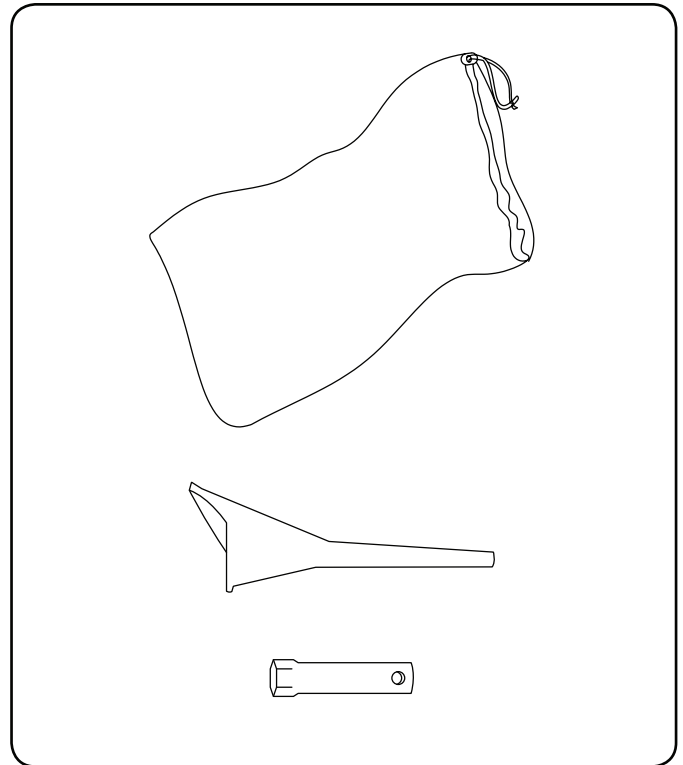

ASSEMBLY

Your chipper-shredder requires some assembly. This unit ships from our factory without oil. It must be properly serviced with fuel and oil before operation.

If you have any questions regarding the assembly of your chipper-shredder, call our help line at 1-877-338-0999. Please have your serial number and model number available.

Unpacking

1. Set the shipping crate on a solid, flat surface
2. Carefully cut the shipping bands and remove lid of shipping crate.
3. Locate all hardware before beginning assembly.

1) Install the Shredder Chute

1. Align the holes in the upper shredder chute (#44) with the holes in the lower shredder chute (#50). (A)

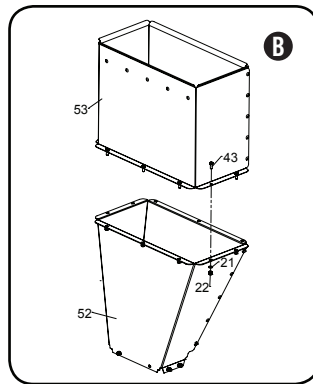
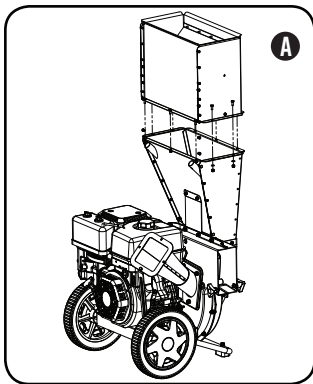

2. Insert M6x15 bolt (#45) into the hole of the chutes, from top to bottom direction. (B)
3. Secure bolt with washer (#11) and lock nut (#12).
4. Tighten till secure. Do not over tighten.
5. Repeat step 2-4 for all holes in the chutes.

NOTE

Make sure chutes are fully secured with all the holes aligned and filled with bolts. If parts are damaged or missing do not use the unit until replacement parts have been obtained.

2) Install the Handle

1. Insert handle (#38) into the brackets on the lower shredder chute.
2. Secure the handle with the M8x35 bolt (#37), lock washer (#24) and washer (#13), and then through the handle on each side.

NOTE: Handle has a threaded and unthreaded hole on each end. Threaded hole goes on the hopper side. This will allow the bolt to tighten properly when assembled.

3. Tighten until secure. Do not over tighten.

Install the Handle Cont'd.

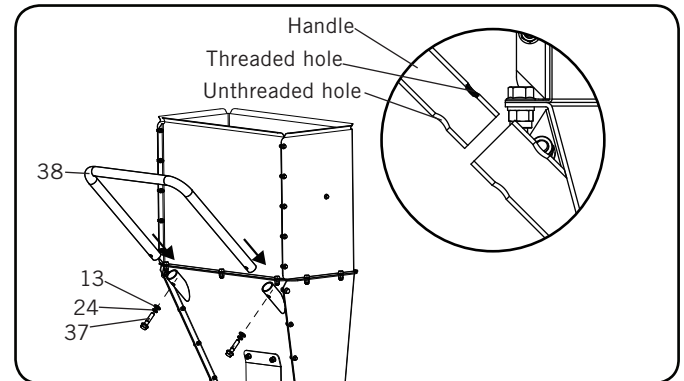

3) Install the Chipper Chute

1. Remove bolt used to secure the support bracket to chute.

NOTE

Only remove bolt, leave bracket in position

2. Line up the upper chipper chute (#17) with the rubber blocker (#19), and with the lower chipper chute (#20). (A)
3. Once aligned, insert bolt (qty. 4) M6x20 (#18) through the hole in the upper and lower chipper chute (Being sure to re-attach support bracket to chute assembly). Insert bolt from top to bottom direction. (B)
4. Secure bolt with washer (#11) and lock nut (#12). (B)
5. Tighten till secure. Do not over tighten.
6. Repeat step 2-4 for all holes in the chutes.

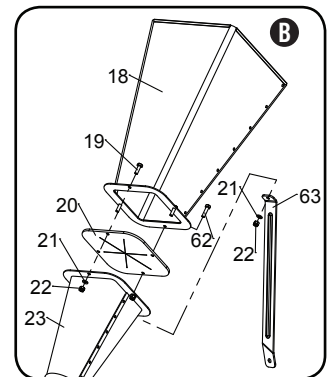
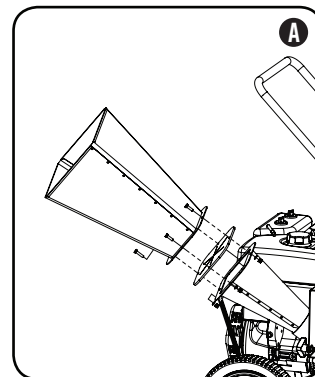

WARNING

Make sure the rubber blocker (#19) is secure between the top and bottom chutes. Do not operate unit if blocker is damaged or missing.

4) Install the Chute Deflector

1. Align the chute deflector (#36) and the hinge spacers (#35) up with the hinge mounting holes on the flailing housing. (A)
2. Slide bolt M6x100 (#48) through the hinge mounting holes, hinge spacers, and chute deflector.
3. Secure with lock nut (#12). Tighten. Do not overtighten.
4. Slide knob bolt (#34) through lock washer (#24) and washer (#13) and then through chute deflector and lower flailing housing assembly.
5. Tighten knob bolt. Do not overtighten.
6. Repeat for second knob bolt.

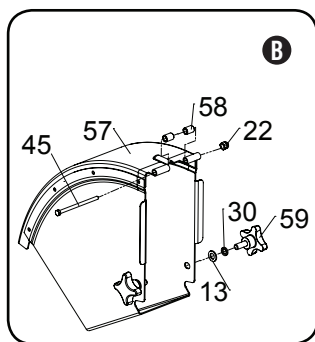
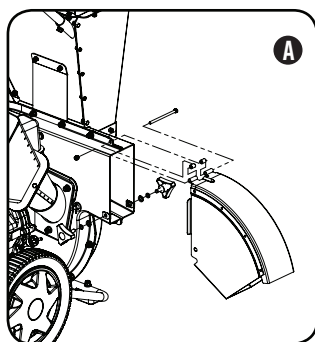

Collection Bag

The collection bag can be attached and removed from the chute deflector using the adjustable drawstring. It is recommended to be attached before operation and removed before completely full, after operation, or before storage. The collection bag will collect up to 2 bushels (70 L) of material.

! WARNING

Before operation, ensure the adjustable drawstring is tight around the chute deflector and secure.

! WARNING

Once the collection bag appears to be almost full, it is recommended to empty it. This will help to keep the bag from becoming dislodged from the deflector chute and also to keep the bag from bursting. Do not allow the collection bag to become dislodged from the deflector chute during operation. If this occurs stop operation at once and let unit cool before reconnecting the collection bag. Only empty the collection bag when the engine is off and the spark plug has been disconnected.

NOTE

Always inspect the collection bag prior to use. Do not use a frayed, worn, or damaged collection bag.

ASSEMBLY

Add Engine Oil

! CAUTION

DO NOT attempt to crank or start the engine before it has been properly filled with the recommended type and amount of oil. Damage to the chipper-shredder as a result of failure to follow these instructions will void your warranty.

NOTE

The recommended oil type is 10W-30 automotive oil.

1. Place the chipper-shredder on a flat, level surface.
2. Remove oil fill cap/dipstick to add oil.
3. Add up to 1.2 qt. (1.1 L) of oil (not included) and replace oil fill cap/dipstick. DO NOT OVERFILL.
4. Check engine oil level daily and add as needed.

NOTE

Once oil has been added, a visual check should show oil about 1-2 threads from running out of the fill hole. If using the dipstick to check oil level, DO NOT screw in the dipstick while checking.

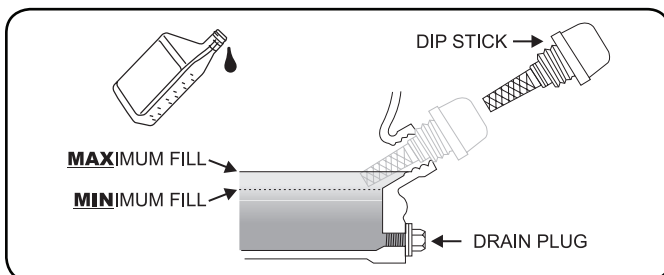

NOTE

Check oil often during the break-in period. Refer to the Maintenance section for recommended service intervals.

Add Engine Oil Cont'd.

CAUTION

The engine is equipped with a low oil shut-off and will stop when the oil level in the crankcase falls below the threshold level.

NOTE

We consider the first 5 hours of run time to be the break-in period for the engine. During the break-in period we recommend using standard automotive non-synthetic blended oils. After the break-in period synthetic lubricant can be used but is not required. Adjusting throttle setting will increase/decrease engine speed helping to seat piston rings. Avoid bogging or lugging the engine down and avoid prolonged running at constant RPM. After the 5 hour break-in period, change the oil. Using synthetic lubricants does not increase the recommended oil change interval.

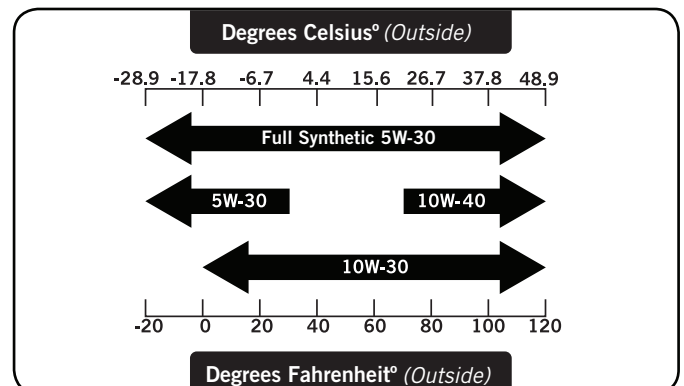

NOTE

Weather will affect engine oil and engine performance. Change the type of engine oil used based on weather conditions to suit the engine needs.

Add Engine Fuel

1. Use clean, fresh, regular unleaded fuel with a minimum octane rating of 85 and an ethanol content of less than 10% by volume.
2. DO NOT mix oil with fuel.
3. Clean the area around the fuel cap.
4. Remove the fuel cap.
5. Slowly add fuel to the tank. DO NOT OVERFILL. Fuel can expand after filling. A minimum of ¼ in. (6.4 mm) of space left in the tank is required for fuel expansion, more than ¼ in. (6.4 mm) is recommended. Fuel can be forced out of the tank as a result of expansion if it is overfilled, and can affect the stable running condition of the product. When filling the tank, it is recommended to leave enough space for the fuel to expand.
6. Screw on the fuel cap and wipe away any spilled fuel.

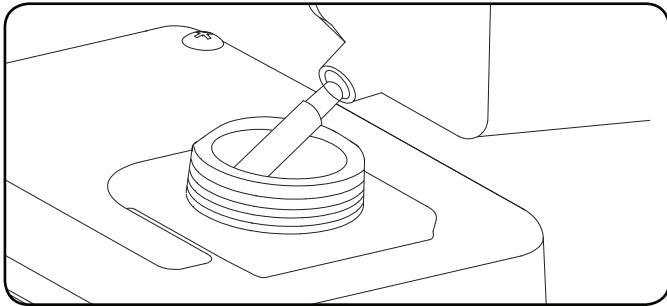

Add Engine Fuel Cont'd.

NOTE

Our engines work well with 10% or less ethanol blend fuels. When using blended fuels there are some issues worth noting:

- Ethanol-gasoline blends can absorb more water than gasoline alone.
- These blends can eventually separate, leaving water or a watery goo in the tank, fuel valve and carburetor.
- With gravity-fed fuel supplies, this compromised fuel can be drawn into the carburetor and cause damage to the engine and/or potential hazards.
- There are only a few suppliers of fuel stabilizer that are formulated to work with ethanol blend fuels.
- Any damages or hazards caused by using improper fuel, improperly stored fuel, and/or improperly formulated stabilizers, are not covered by manufacture's warranty.

It is advisable to always shut off the fuel supply, run the engine to fuel starvation and drain the tank when the equipment is not in use for more than 30 days.

CAUTION

Use regular unleaded gasoline with a minimum octane rating of 85.

- Do not mix oil and gasoline.
- Fill tank to approximately ¼ in. (6.4 mm) below the top of the tank to allow for fuel expansion.
- DO NOT pump gas directly into the engine at the gas station. Use an approved container to transfer the fuel to the engine.
- DO NOT fill fuel tank indoors.
- DO NOT fill fuel tank when the engine is running or hot.
- DO NOT overfill the fuel tank.
- DO NOT light cigarettes or smoke when filling the fuel tank.

WARNING

Pouring fuel too fast through the fuel screen may result in blow back of fuel at the operator while filling.

OPERATION

Chipper-Shredder Location

Never operate the chipper-shredder indoors or inside any confined spaces, enclosures or buildings; including garages, basements, and sheds. The chipper-shredder must have at least 5 ft. (1.5 m) of clearance on all sides from combustible materials at all times. The chipper-shredder must also have 3 ft. (91.4 cm) or more of clearance on all sides of the at all times to allow for adequate cooling, maintenance and servicing. Chipper-shredders should never be started or operated in the bed of a truck (regular, flat or otherwise), under staircases/stairwells, next to walls or buildings, or in any other location that will not allow for adequate cooling of the unit and/or the muffler, or adequate safety to the operator, assistants, or bystanders. Place the chipper-shredder in a well-ventilated area. DO NOT place the chipper-shredder near vents or intakes where exhaust fumes could be drawn into occupied or confined spaces. Carefully consider wind and air currents when positioning the unit. Allow the unit to properly cool before transport or storage. The chipper-shredder needs to be on a dry level surface with good footing. (Even while not in operation) DO NOT work on mud, ice, tall grass, brush or snow. DO NOT work on asphalt, brick, rock, concrete or other harden surfaces. DO NOT position the unit next to or facing any buildings, walls or fences, that could cause any projectiles to ricochet back at the operator or bystanders.

WARNING

During operation the muffler and exhaust fumes produced will become hot. If adequate cooling and breathing space are not supplied, or if the chipper-shredder is blocked or contained, temperatures can become extremely heated and may lead to fire.

Work Area

Always operate the chipper-shredder outdoors in a large, open area on solid ground that will allow for good footing and ventilation. Keep a clean and clear immediate area around the chipper-shredder at all times. Ensure no pets, children or bystanders are in the immediate or surrounding areas at any time. Debris and projectiles can be launched up to 75 ft. (22.9 m) in diameter in all directions surrounding the chipper-shredder. Assistants must also be out of the immediate and surrounding areas while chipping or shredding is being performed. The operator must be in the "Safe Zone" at all times when the spark plug wire is connected and/or the engine is on.

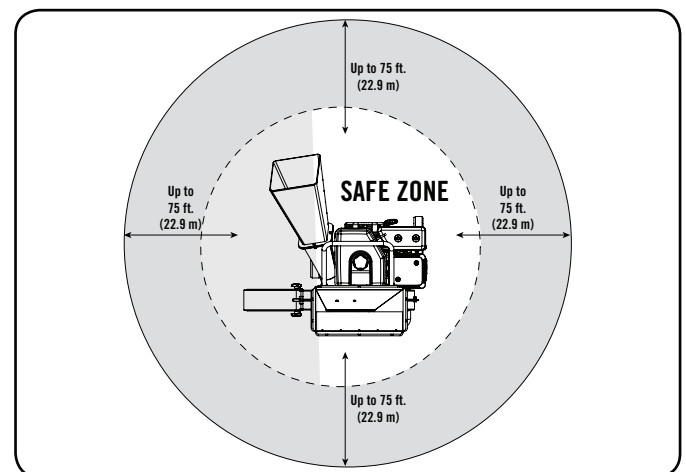
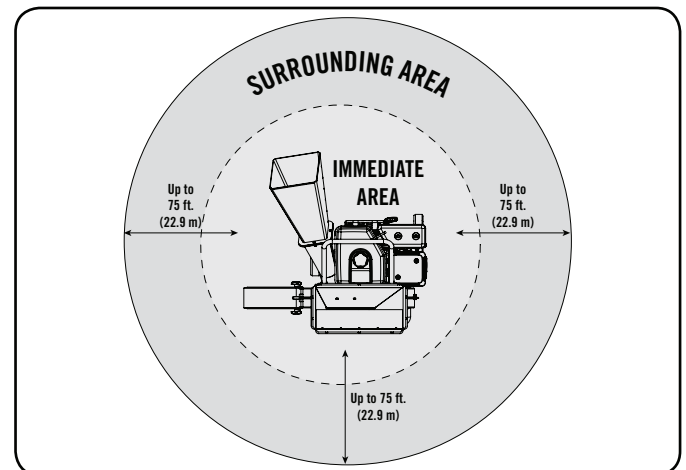

DANGER

Never stand directly in front of the chipper chute or deflector chute. Do not lean over or reach across the shredder chute. Debris and projectiles may be discharged through these areas and may cause damage or injury.

Before Each Use Inspect the Chipper-Shredder

1. Make sure the spark plug wire has been disconnected and engine has been grounded.
2. Visually inspect all attachments and chutes for loose fittings, cracks, fraying or other damage.
3. DO NOT operate the chipper-shredder if there is any indication of damage to parts or the unit.
4. DO NOT operate the chipper-shredder if there are any clogged chutes. Remove all debris before operation.
5. Inspect the engine and make sure the oil level and fuel level are correct before operating.
6. Clean and inspect the spark arrestor regularly (follow spark arrestor maintenance schedule).
7. Inspect the collection bag for any fraying, holes or damage. Never use a damaged collection bag.
8. Inspect the work area for any distractions or elements that may prevent operator safety or proper operation.

DANGER

DO NOT operate a damaged chipper-shredder, or one with damaged or loose parts. Operating a damaged unit or one with loose parts may cause damage to the product or injury to the user. Make sure all parts are in good condition and secure before operation.

Starting the Engine

1. Make certain the chipper-shredder is on a flat, level surface.
2. Re-attach the spark plug wire to the spark plug. Make sure the connection is secure.
3. Turn engine switch to “ON” position. (A)
4. Turn the fuel valve to the “ON” position. (B)
5. Move the throttle level to the middle position. (C)
6. Move the choke lever to the “Choke” position. (D)

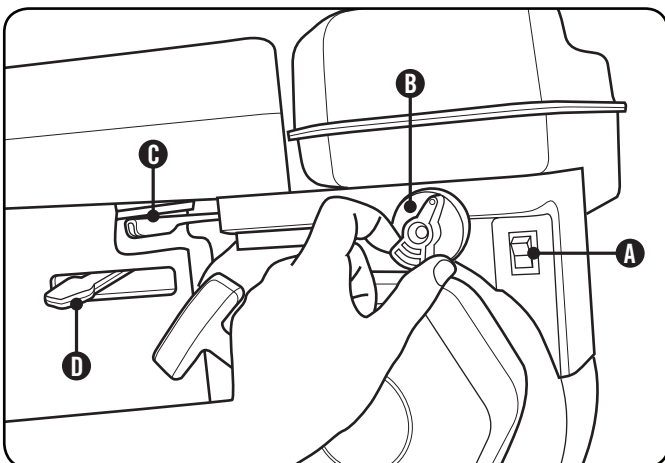

Starting the Engine Cont'd.

7. Pull the starter cord slowly until resistance is felt and then pull rapidly. **SEE NOTE BELOW.**
8. As engine warms up, move the choke lever to “Run.” (D)
9. Move the throttle lever to the “Fast” position. (C)

NOTE

Keep choke lever in “Choke” position for only 1 pull of the recoil starter. After first pull, move choke lever to the “Run” position for up to the next 3 pulls of the recoil starter. Too much choke leads to spark plug fouling/engine flooding due to the lack of incoming air. This will cause the engine not to start.

NOTE

If the engine starts but does not run make certain that the chipper-shredder is on a flat, level surface. The engine is equipped with a low oil sensor that will prevent the engine from running when the oil level falls below a critical threshold.

NOTE

Pulling the recoil cord will spin the impeller and this will make noises. These noises are normal and should be made as the cord is pulled and the impeller spins.

OPERATION

Chipper-Shredder Operation

DANGER

This machine has rotating blades and parts capable of amputating body parts. This machine can also throw objects at high velocity, long distances. Exercise extreme caution when operating the chipper-shredder. NEVER insert body parts or foreign object into any chute at any time. Never look directly into any chute, as projectiles can backfire.

1. ALWAYS wear ear and eye protection, protective shoes and clothing, and proper safety gear.

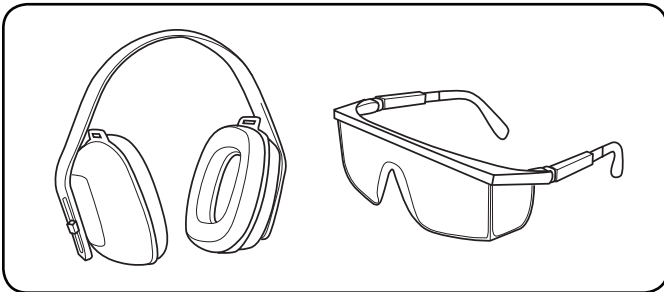

2. Block tires and put both support mounts in the DOWN position to prevent unintended movement of the chipper-shredder during operation.
3. Tie back long hair. Do not wear loose fitting clothing or jewelry.
4. Make sure surrounding, immediate and safe zones are clear of distractions and debris.
5. Do not attempt to chip or shred material that is larger than specified. This may damage the unit or cause injury.
6. Make sure the materials that are going to be chipped or shredded are free of any rocks, trash, metals and other foreign objects.
7. Make sure wood to be chipped has been "trimmed" down and do not have any excessive branches.
8. Make sure wood to be chipped or leaves/brush to be shredded are not "wet" as this may clog the chutes.
9. Keep all chutes, deflectors and guards assembled and in place at all times.

Chipper-Shredder Operation Cont'd.

DANGER

If the impeller or blades strike a foreign object, stop engine immediately. Do not continue use until chutes and unit have been thoroughly inspected. Do not attempt to unclog any jam or chute while engine is on or spark plug wire is connected.

WARNING

ALWAYS use the chipper-shredder for its intended uses only. The chipper-shredder should only be used to chip branches 3 in. (7.6 cm) or less in diameter, or to shred leaves and brush. DO NOT chip anything that is larger than 3 in. (7.6 cm) in diameter.

NEVER modify, alter or change the chipper-shredder in anyway. Modifications will void the warranty and may result in damage or injury. DO NOT modify or change the engine and operating speeds. These changes can cause safety issues. ONLY operate the chipper-shredder in daylight. NEVER operate, or let anyone else operate, the chipper-shredder while under the influence of alcohol, drugs, or medication. NEVER leave the chipper-shredder unattended while the engine is running. Avoid contact with the muffler, as it can cause serious burns.

NOTE

Always be aware of who and what is in the immediate and surrounding areas of the chipper-shredder. Operators should always work in the SAFE ZONE only.

Chipping and Shredding Tips

Chipping

1. Make sure wood is less than 3 in. (7.6 cm) in diameter.
2. Make sure wood is dry.
3. Make sure all smaller branches have been pruned for the wood.
4. Make sure pieces are long enough to be fed through the chute.
5. Large pieces can be rotated and alternately inserted and retracted as they are fed.
6. Always maintain control with two hands of what is being fed, to prevent “whipping” around.
7. Standing in the safe zone will prevent any damage or injury if a piece is kicked back out of the chute.

WARNING

Never insert pieces larger than 3 in. (7.6 cm) in diameter as this may cause damage or injury.

Small pieces may be fed carefully using a larger piece. Never insert smaller pieces using your hands.

If larger pieces will not chip, get pushed backed by the chipper, or can not be controlled, remove at once.

Never feed more than one branch or piece of wood into the chute at a time.

Shredding

1. Inserting smaller loads at a time will prevent overloading of the chute.
2. Make sure material is dry.
3. Make sure material is free of trash, metal, rocks, and foreign objects.
4. Air flow will draw loads into the chute, pushing or shoving the loads is not necessary.
5. Branches larger than 1/2 in. (1.3 cm) in diameter are not recommended, as they can damage the blades.
6. Vines are not recommended as they can clog or damage the blades.

WARNING

Never insert any item into the chute to “assist” in the feeding of any load.

Never insert completely wet material into the chute. If material is “damp” then alternate with dry loads to prevent clogging.

Chipping and Shredding Tips Cont'd.

NOTE

After all material has been processed it is recommended that the unit run for short period to clear out any left over material that may still be in the chutes or flail housing.

Clearing the Shredding Chute

If the shredding chute gets slightly clogged, then firmly grasp the handle and gently rock the unit back and forth to try and dislodge or shift the material that may be causing the clog. This may help to loosen and draw the material better into the flail housing and impeller. If slightly rocking the unit fails then:

1. Stop the engine.
2. Turn the fuel valve to the “OFF” position.
3. Disconnect the spark plug wire.
4. Using your hands, remove the material that is still atop the shredding chute. DO NOT stick your hands in the chute, only remove the material on top.
5. Using a branch, or other piece of wood less than 1/2 in. (1.3 cm) in diameter try and dislodge the material.
6. Once cleared, remove the branch, reconnect the spark plug wire, turn the fuel valve “ON,” and restart the engine.

NOTE

If the clog appears to be serious, then shut the engine off, disconnect the spark plug wire, and allow the unit to cool before draining the fuel and opening the flail housing to remove the clogged material.

OPERATION

Emptying the Collection Bag

1. Turn the throttle down to the "SLOW" position.
2. Stop the engine.
3. Turn the fuel valve to the "OFF" position.
4. Disconnect the spark plug wire.
5. Using your hands, release the draw string on the collection bag.
6. Remove the collection bag from the deflector chute and empty bag.
7. Once emptied, reconnect the collection bag by pulling the draw string tight, then reconnect the spark plug wire, turn the fuel valve "ON," and restart the engine.

NOTE

Do not let the collection bag fill to capacity before emptying. It is recommended to empty the bag before it fills completely to minimize damage to the bag.

Stopping the Engine

1. Turn the throttle down to the "SLOW" position.
2. Turn the fuel valve to the "OFF" position.
3. Let the engine run until fuel starvation has stopped the engine. This usually takes a few minutes.
4. Turn the engine switch to the "OFF" position.
5. Disconnect spark plug wire.

Important: Always ensure that the Fuel Valve and the Engine Switch are in the "OFF" position when the engine is not in use.

NOTE

If the engine will not be used for a period of two (2) weeks or longer, please see the Storage section for proper engine and fuel storage.

NOTE

As the engine shuts off and the blades wind down, some noises in the flail housing can be made, these are normal, but any weird noises may be damage and if these occur the unit should be inspected.

Operation at High Altitude

The density of air at high altitude is lower than at sea level. Engine power is reduced as the air mass and air-fuel ratio decrease. Engine power and output will be reduced approximately 3½% for every 1000 feet of elevation above sea level. This is a natural trend and cannot be changed by adjusting the engine. At high altitudes increased exhaust emissions can also result due to the increased enrichment of the air fuel ratio. Other high altitude issues can include hard starting, increased fuel consumption and spark plug fouling. To alleviate high altitude issues other than the natural power loss, Champion Power Equipment can provide a high altitude carburetor main jet. The alternative main jet and installation instructions can be obtained by contacting Customer Support. Installation instructions are also available in the Technical Bulletin area of the Champion Power Equipment internet site. The part number and recommended minimum altitude for the application of the high altitude carburetor main jet is listed in the table below.

In order to select the correct high altitude main jet it is necessary to identify the carburetor model. For this purpose, a code is stamped on the side of the carburetor. Select the correct main jet part number corresponding to the carburetor code found on your particular carburetor.

Carburetor Code	Main Jet	Part Number	Altitude
P23-1-Z	Standard	46.131017.01.Z	4500 Feet (1372 Meters)
	Altitude	46.131017.01.01.Z	
P23-1-H	Standard	46.131017.01.H	
	Altitude	46.131017.01.01.H	
P23-1-Y	Standard	46.131017.01.Y	
	Altitude	46.131017.01.01.Y	

WARNING

Operation using the alternative main jet at elevations lower than the recommended minimum altitude can damage the engine. For operation at lower elevations, the standard main jet must be used. Operating the engine with the wrong engine configuration at a given altitude may increase its emissions and decrease fuel efficiency and performance.

The owner/operator is responsible for all periodic maintenance.

⚠ DANGER

Always disconnect the spark plug wire during times of inactivity, cleaning and maintenance. This will prevent any accidental start up that may cause damage or injury.

⚠ WARNING

Never operate a damaged or defective chipper-shredder.

⚠ WARNING

Improper or neglected maintenance will void your warranty.

💬 NOTE

For service or parts assistance, contact our help line at **1-877-338-0999**.

Complete all scheduled maintenance in a timely manner. Correct any issue before operating the log splitter.

Engine Maintenance

To prevent accidental starting, remove and ground spark plug wire before performing any service.

Oil

Change oil when the engine is warm. Refer to the oil specification to select the proper grade of oil for your operating environment.

1. Remove the oil drain plug with a 15 mm socket and extension. (Not included)
2. Allow the oil to drain completely.
3. Replace the drain plug.
4. Remove oil fill cap/dipstick to add oil.
5. Add up to 1.2 qt (1.1 L) of oil and replace oil fill cap/dipstick. **DO NOT OVERFILL.**
6. Dispose of used oil at an approved waste management facility.

Oil Cont'd.

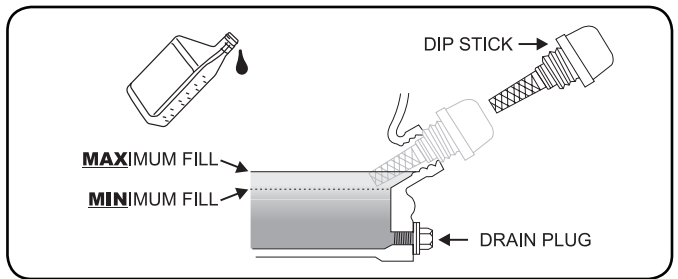

💬 NOTE

Once oil has been added, a visual check should show oil about 1-2 threads from running out of the fill hole. If using the dipstick to check oil level, **DO NOT** screw in the dipstick while checking.

⚠ WARNING

Used oil is a hazardous waste product and must be disposed of properly. Do not discard with household waste. Check with your local authorities, service center, or dealer for safe disposal/recycling facilities.

Spark Plugs

1. Remove the spark plug cable from the spark plug.
2. Use a spark plug socket (included) to remove the plug.
3. Inspect the electrode on the plug. It must be clean and not worn to produce the spark required for ignition.
4. Make certain the spark plug gap is 0.7 - 0.8 mm (0.028 - 0.031 in.).

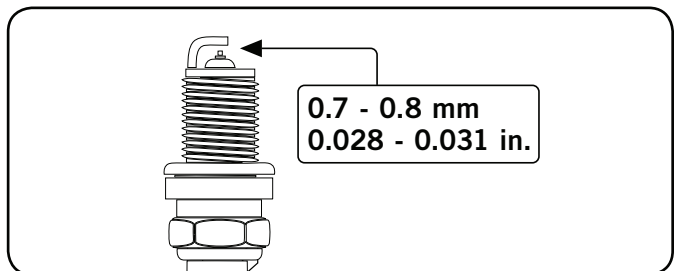

5. Refer to the spark plug section on the Specifications page when replacing the plug.
6. Carefully thread the plug into the engine.
7. Use a spark plug socket (included) to firmly install the plug.
8. Attach the spark plug wire to the plug.

MAINTENANCE AND STORAGE

Air Filter

1. Unscrew wing nut to remove the air filter cover.
2. Remove the supporter and foam element.
3. Tap the foam element to remove dirt and debris. Use compressed air (25 PSI) to clear debris.
4. For the foam element: Wash in liquid detergent and water. Squeeze thoroughly dry in a clean cloth.
5. Saturate in clean engine oil.
6. Squeeze in a clean, absorbent cloth to remove all excess oil.
7. Reassemble the elements and the supporter.
8. Reattach the air filter cover and snap in place.
9. Tighten wing nuts.

Chipper-Shredder Maintenance

Make certain that the chipper-shredder is kept clean and stored properly. Only operate the unit on a flat, level surface in a clean, dry operating environment. DO NOT expose the unit to extreme conditions, excessive dust, dirt, moisture or corrosive vapors.

Inspect all air vents and cooling slots to ensure that they are clean and unobstructed.

Inspect all chutes and housing and make sure they are free of dirt, dust, and debris.

Check and tighten all bolts and nuts. It is possible for connections to vibrate loose over time.

Cleaning

⚠ CAUTION

DO NOT use a garden hose or water to clean the engine or chipper-shredder.

Water can contaminate the fuel system and can enter the engine through the cooling slots and damage the engine.

Clear the debris from the chutes and engine. Use a damp cloth to clean exterior surfaces of the engine and chipper-shredder.

Use a soft bristle brush to remove excess dirt and oil. Use an air compressor (25 PSI) to clear dirt and small debris. Wipe all metal parts with an oily rag to help prevent rust and corrosion.

Flail Housing and Impeller Cleaning

1. Make sure spark plug wire is disconnected.
2. Disconnect the recoil housing on the front of the engine.
3. Disconnect the deflector chute #36. (A)
4. Disconnect the upper #44 and lower #50 hopper assemblies, the inlet guide #51 and the outer flail housing assembly #53, all together. (B)
5. Disconnect the shredder screen #33. (C)
6. Use compressed air (25 PSI) or brush to clean the inner flail housing assembly #22, impeller assembly #28, flail blades #26, and shredder blades #29.
7. Once all debris and dust has been blown out or removed, reconnect the shredder screen, outer flail housing, inlet guide, hopper assemblies, and the deflector chute, making sure all bolts and nuts are tightened. Do not over tighten.

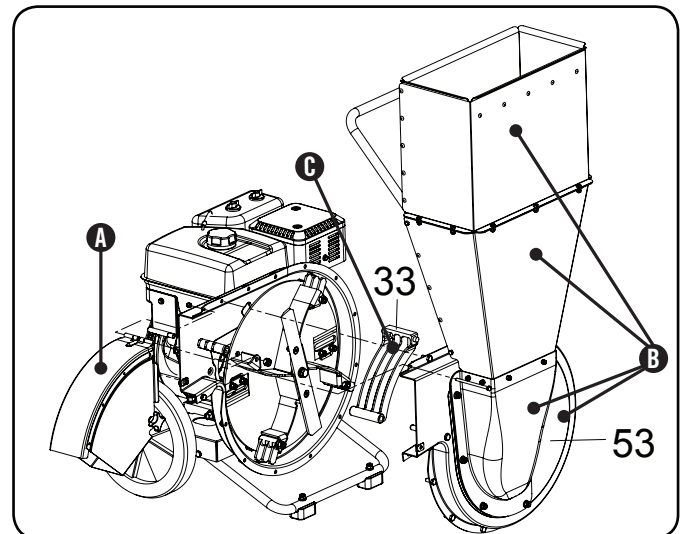

⚠ WARNING

Do not use the chipper-shredder if any part is lost or damaged while cleaning. Get lost or damaged parts replaced before use. Do not use the chipper-shredder if any part is loose, not fitting correctly or not fully re-assembled.

Blade Sharpening

Sharpening of the shredder blade, flail blades and chipper blades are required maintenance to be performed by a professional service center or knowledgeable and experienced owners only. Sharpening of the blades will keep the chipper-shredder performing at a higher quality than with dull blades. Sharp blades will chip or shred material faster and easier, and cause the engine and other parts to work less. Blades are not covered under warranty as they are a wear item, and therefore should be sharpened regularly to keep their edge and to ensure a longer life of the blades, other parts and engine.

1. Make sure spark plug wire is disconnected.
2. Disconnect the recoil housing on the front of the engine.
3. To get to the blades and impeller, the outer flail housing assembly (#53) must be removed. The steps in the flail housing and impeller cleaning section should be followed to remove it and the shredder screen (#33). (A)

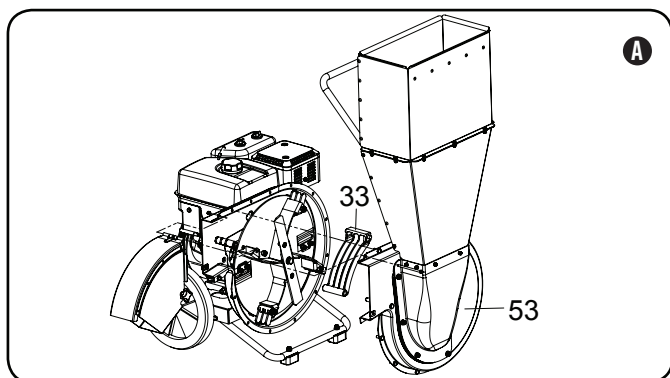

4. Once the outer flail housing and shredder screen are removed, remove the 7/16 screw (#32), 7/16 lock washer (#31) and washer $\varnothing 12$ (#30) from the engine cam shaft. (B)
5. DO NOT remove the flat key (#15) when removing the screw, washers.

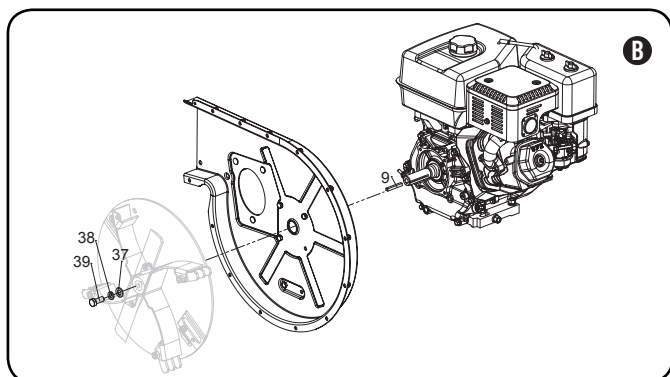

Blade Sharpening Cont'd.

6. Once the 7/16 screw, lock washer, and washer are removed, the impeller (#28) can be removed from the cam shaft of the engine.
7. Removing the impeller will make it easier to remove and sharpen the shredder blade, flail blades, and chipper blades.
8. To remove the shredder blade (#29), unscrew both the M8x25 bolts (#54), washers $\varnothing 8$ (#13), lock washers $\varnothing 8$ (#24) and M8 lock nuts (#55). (C)

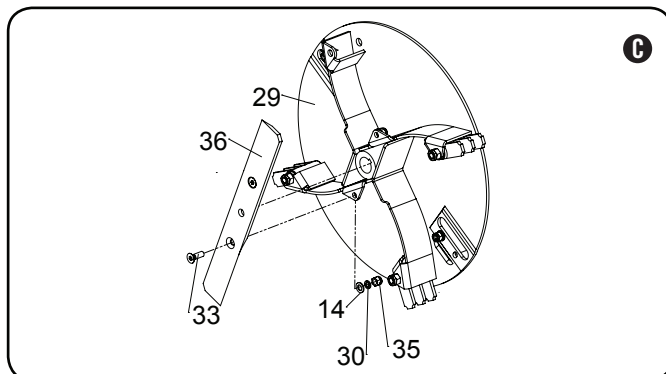

9. To remove the flail blades (#26), unscrew the M10 lock nut (#27) from the shoulder pin (#25). (D)
10. Repeat for all 4 flail blades.

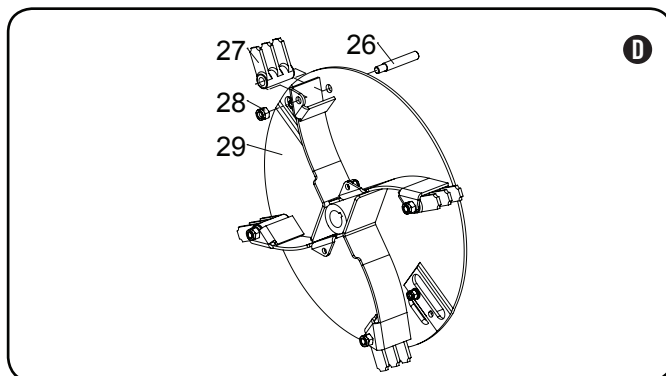

11. To remove the chipper blade (#56), unscrew M8 lock nut (#55), lock washer $\varnothing 8$ (#24), washer $\varnothing 8$ (#13) from the M8x25 bolt (#54). Each chipper blade is secured with two M8x25 bolts, lock washer, washer and lock nut. (E)
12. Repeat for second chipper blade.

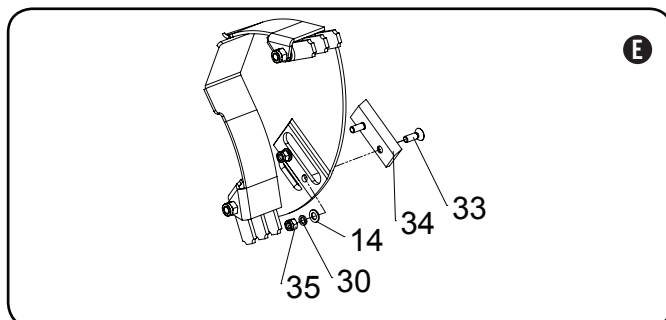

MAINTENANCE AND STORAGE

Maintenance Schedule

Follow the service intervals indicated in the schedule below. Service your chipper-shredder more frequently when operating in adverse conditions. Contact our help line at **1-877-338-0999** to locate the nearest Champion Power Equipment authorized service dealer for your chipper-shredder or engine maintenance needs.

Every time of use or daily	
	Check engine oil level
	Clean around air intake and muffler
	Check air filter
	Check for loose or damaged parts
	Inspect all chutes and guards
First 5 Hours	
	Change engine oil (break in period)
Every 25 Hours or per 1 month	
	Change engine oil
	Clean air filter
	Inspect all blades, sharpen if needed
Every 50 hours or per 6 months	
	Clean and adjust spark plug
	Check cooling fan
Every 100 hours or per 1 year	
	Check/adjust valve clearance*
	Clean fuel tank and filter*
Every 200 hours or per 2 years	
	Check/replace fuel line
	Change spark plug
Every 250 hours	
	Clean combustion chamber

*To be performed by knowledgeable, experienced owners or Champion Power Equipment certified dealers.

Storage

Refer to the maintenance sections for proper cleaning instructions. Always disconnect the spark plug wire in times of inactivity, maintenance, and storage. This will help to prevent any unintended engine start ups.

WARNING

Never store the chipper-shredder inside next to appliances where there is a source of heat or open flame, spark or pilot light because they can ignite gasoline vapours. DO NOT store a chipper-shredder near fertilizer or any corrosive material.

Even with an empty gas tank, gasoline vapours could ignite.

Chipper-shredder Storage

1. The chipper-shredder needs to be cool for at least 5 minutes before storing.
2. Clean the chipper-shredder before storage according to the Maintenance section.
3. Store the unit in a clean, dry place out of direct sunlight.

Engine Stored for Less than 30 Days

1. Add a properly formulated fuel stabilizer to the tank.
2. Run the engine for a few minutes so the treated fuel cycles through the fuel system and carburetor.
3. Turn the fuel valve to the "Off" position.
4. Let the engine run until fuel starvation has stopped the engine. This usually takes a few minutes.
5. The engine needs to cool completely before cleaning and storage.
6. Clean the engine according to the maintenance section.

Engines Stored for Over 30 Days

1. Add a properly formulated fuel stabilizer to the tank.
2. Run the engine for a few minutes so the treated fuel cycles through the fuel system and carburetor.
3. Turn the fuel valve to the "Off" position.
4. Let the engine run until fuel starvation has stopped the engine. This usually takes a few minutes.
5. The engine needs to cool completely before cleaning and storage.
6. Clean the engine according to the maintenance section.
7. Change the oil.
8. Remove the spark plug and pour about 1/2 ounce (14.8 mL) of oil into the cylinder. Crank the engine slowly to distribute the oil and lubricate the cylinder.

Chipper-Shredder Specifications

- Max Diameter Chipper Material 3 in. (7.6 cm)
- Max Diameter Shredder Material 0.5 in. (1.3 cm)
- **Overall Dimensions**
- Gross Weight 224.9 lb. (102 kg)
- Net Weight 189.6 lb. (86 kg)
- Height 49.4 in. (125.5 cm)
- Width 35 in. (89 cm)
- Length 35.1 in. (89.2 cm)

Engine Specifications

- Model YF182F-000
- Displacement 338 cc
- Type 4-Stroke OHV
- Start Type Recoil

Fuel

Fuel capacity is 1.6 gallons (6.2 L). Use regular unleaded gasoline with a minimum octane rating of 85 and an ethanol content of less than 10% by volume.

Oil

Use 10W-30 automotive oil.

Oil capacity is 1.2 qt. (1.1 L).

DO NOT OVERFILL.

Please reference the following chart for recommended oil types for use in the chipper-shredder.

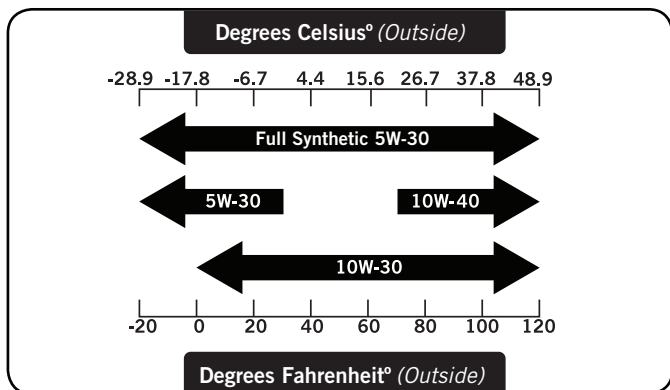

Spark Plugs

OEM spark plug: NHSP F6RTC

Replacement spark plug: NGK BPR6ES or equivalent
 Make certain the spark plug gap is 0.7 - 0.8 mm or (0.028 - 0.031 in.).

Maintenance Valve Clearance

- Intake: 0.13 – 0.17 mm (0.005 – 0.007 in.)
- Exhaust: 0.18 – 0.22 mm (0.007 – 0.009 in.)

Note: Tech bulletin regarding the valve adjustment procedure is on www.championpowerequipment.com.

An Important Message About Temperature

Your Champion Power Equipment product is designed and rated for continuous operation at ambient temperatures up to 40°C (104°F). When your product is needed your product may be operated at temperatures ranging from -15°C (5°F) to 50°C (122°F) for short periods. If the product is exposed to temperatures outside this range during storage, it should be brought back within this range before operation. In any event, the product must always be operated outdoors, in a well-ventilated area and away from doors, windows and other vents.

NOTE

Weather will affect engine oil and engine performance. Change the type of engine oil used based on weather conditions to suit the engine needs.

SPECIFICATIONS

Parts Diagram

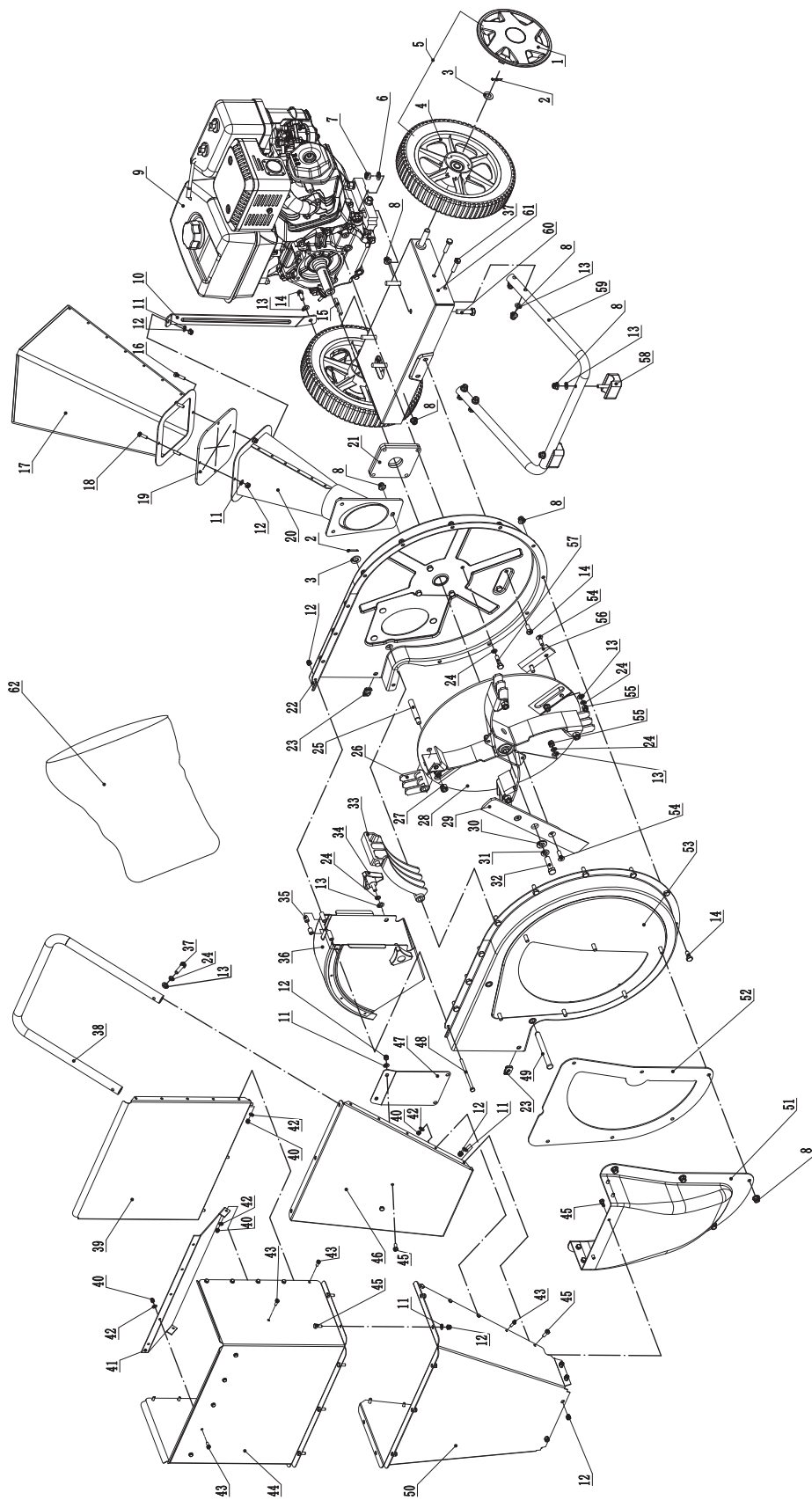

#	Part number	Description	Qty
1	601.201702.00.48	Wheel Cap, Yellow	2
2	1.91.3220	Cotter Pin, Ø3.2 x 20	3
3	1.97.1.13	Washer, Ø13	3
4	601.201701.00	12 in.Wheel	2
5	601.20170.00.48	12 in. Wheel Assembly, Yellow	2
6	1.97.1.10	Washer, Ø10	4
7	1.6177.1.10	Nut, M10	4
8	1.6187.08	Flange Nut, M8	31
9	44.102	Engine	1
10	601.300027.00.1	Chute Support Bracket, Black	1
11	1.97.1.06	Washer, Ø6	26
12	1.6182.06	Lock Nut, M6	27
13	1.97.1.08	Washer, Ø8	17
14	1.16674.0820	Bolt, M8 x 20	16
15	2.14.002	Flat Key, 6.3 x 6.3 x 50	1
16	1.5789.0625	Flange Bolt, M6 x 25	1
17	601.300120.00.48	Upper Chipper Chute Assembly, Yellow	1
18	1.5789.0620	Flange Bolt, M6 x 20	3
19	601.300103.00	Block Rubber	1
20	601.300110.00.48	Lower Chipper Chute Assembly, Yellow	1
21	601.300600.00.1	Engine Plate Assembly, Black	1
22	601.300200.00.1	Inner Flail Housing Assembly, Black	1
23	2.02.032	U Nut, M8	2
24	1.93.08	Lock Washer, Ø8	14
25	601.303005.00	Shoulder Pin	4
26	601.303003.00.2	Flail Blade, Black	4
27	1.6182.10	Lock Nut, M10	4
28	601.303100.00.2	Impeller Assembly, Black	1
29	601.303004.00	Shredder Blade	1
30	601.300024.00	Washer	1
31	1.93.12	Lock Washer, Ø12	1
32	2.08.136	Screw, 7/16 - 20UNF	1
33	601.300008.00.2	Shredder Screen, Black	1
34	601.300020.00	Knob, M8	2
35	601.300018.00	Hinge Spacer	2
36	601.300400.00.1	Chute Deflector Assembly, Black	1

#	Part number	Description	Qty
37	1.5789.0835	Flange Bolt, M8 x 35	6
38	601.301703.00.1	Hopper Handle, Black	1
39	601.301708.00.48	Upper Hopper Back Assembly, Yellow	1
40	1.6182.05	Lock Nut, M5	23
41	601.301704.00.48	Baffle, Yellow	1
42	1.97.1.05	Washer, Ø5	17
43	1.16674.0512.2	Bolt, M5 x 12	23
44	601.301709.00.48	Upper Hopper Front Assembly, Yellow	1
45	1.5789.0615	Flange Bolt, M6 x 15	22
46	601.301710.00.48	Lower Hopper Back Assembly, Yellow	1
47	601.300014.00.1	Hopper Support Bracket, Black	1
48	1.5782.06100	Bolt, M6 x 100	1
49	601.300022.00	Clevis Pin	1
50	601.301702.00.48	Lower Hopper Front Assembly, Yellow	1
51	601.300013.00.1	Inlet Guide, Black	1
52	601.300007.00.1	Shredder Plate, Black	1
53	601.300500.00.1	Outer Flail Housing Assembly, Black	1
54	1.70.3.0825	Machine Screw, M8 x 25	6
55	1.6182.08	Lock Nut, M8	6
56	601.303002.00	Chipper Blade	2
57	2.08.137	Bolt , 5/16 - 24UNF	4
58	601.300021.00	Rubber Cushion	2
59	601.300011.00.1	Tube Support, Black	1
60	1.5783.1040	Bolt, M10 x 40	4
61	601.300900.00.1	Frame Assembly, Black	1
62	9.1400.001	Collection Bag	1

SPECIFICATIONS

Engine Parts Diagram

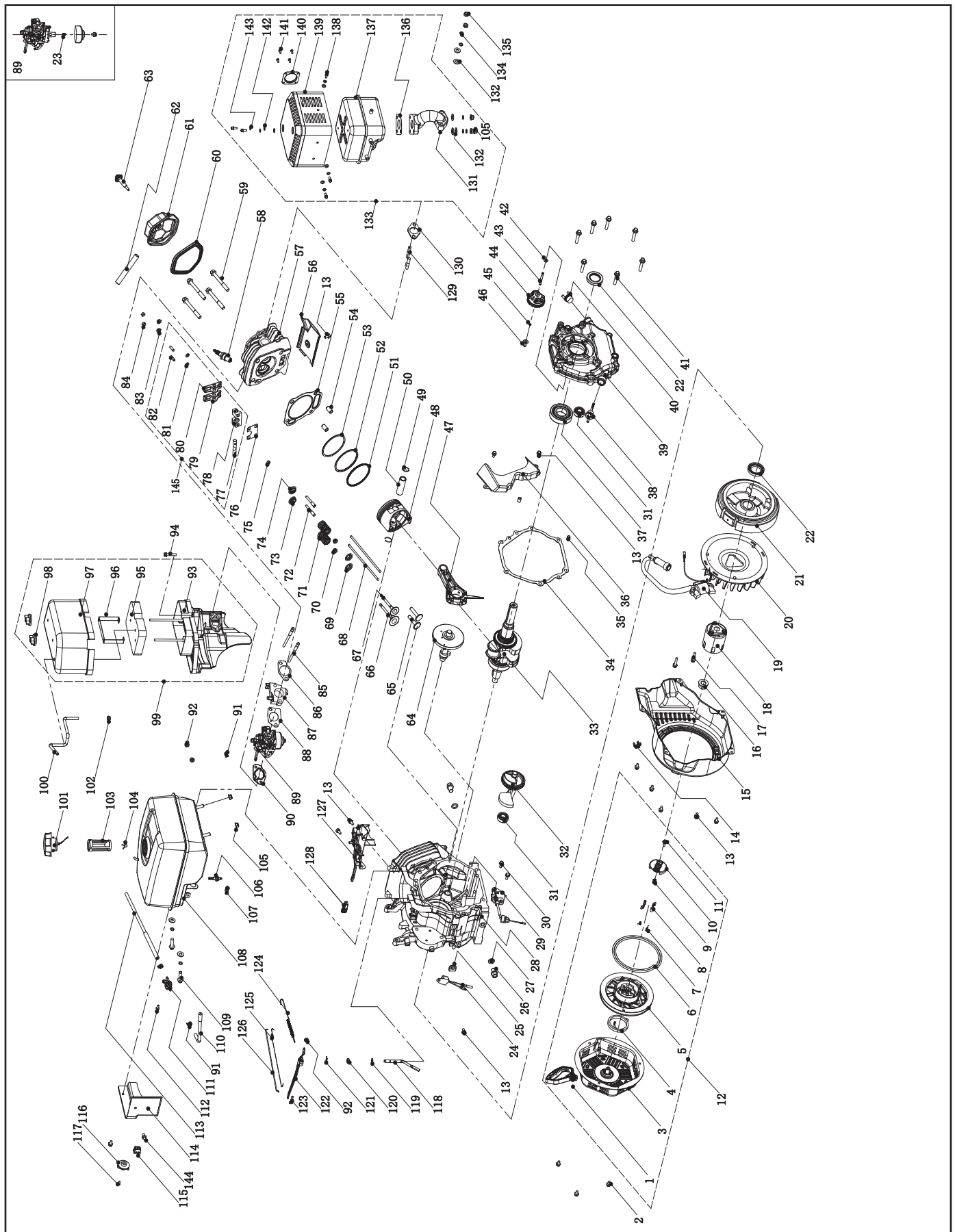

#	Part Number	Description	Qty
1	23.061006.01	Recoil Handle, Big	1
2	1.5789.0608	Flange Bolt M6 x 8	3
3	46.061100.02	Recoil Starter Cover, Black	1
4	45.060005.00	Recoil Starter Spring	1
5	45.061102.00	Recoil Starter Reel	1
6	2.10.003.1	Rope Ø4 x 1550, Black	1
7	45.060003.00	Spring, Ratchet	2
8	45.060002.00	Starter Ratchet, Iron	2
9	45.060009.00	Spring, Ratchet Guide	1
10	45.060007.00	Ratchet Guide	1
11	45.060008.00	Screw, Ratchet Guide	1
12	46.061000.01	Recoil Assembly	1
13	1.5789.0612	Flange Bolt M6 x 12	11
14	2.05.003	Clamp Ø11.5 x 10	1
15	46.080100.00.48	Fan Cover, Yellow	1
16	2.02.007	Nut M16 x 1.5	1
17	1.5789.0629	Flange Bolt M6 x 29	2
18	45.060001.00	Pulley, Starter	1
19	46.123000.01	Ignition Coil	1
20	45.080001.00	Cooling Fan	1
21	46.120100.03	Flywheel, Manual Start EPA	1
22	2.11.007	Oil Seal Ø35 x Ø52 x 8	2
23	46.131017.01	Standard Main Jet	1
	46.131017.01.01	Altitude Main Jet	/
24	21.120400.00	Diode Assembly	1
25	45.030032.00	Sheath, Wire	1
26	2.08.039	Drain Bolt M12 x 1.5 x 15	2
27	2.03.023	Washer Ø12.5 x Ø20 x 2	2
28	46.030100.00	Crankcase	1
29	45.127000.02	Oil Level Sensor	1
30	1.5789.0615	Flange Bolt M6 x 15	2
31	1.276.6202	Bearing 6202	2
32	47.050006.00	Weight Balancer	1
33	45.050100.09	Crankshaft	1
34	46.030008.00	Gasket, Crankcase Cover	1
35	2.04.001	Dowel Pin Ø9 x 14	2
36	46.080600.00	Air Guide, Right Side	1
37	1.276.6207	Bearing 6207	1
38	46.031000.01.48	Oil Dipstick Assembly, Yellow	1
39	45.030007.01	Cover, Crankcase	1
40	22.031000.01.48	Oil Filler Cap, Yellow	1
41	1.5789.0840	Flange Bolt M8 x 40	7
42	2.03.021.1	Washer Ø6.4 x Ø13 x 1, Black	1
43	45.110013.00	Shaft, Governor Gear	1
44	45.110100.00	Governor Gear	1
45	21.110011.00	Clip, Governor Gear	1
46	45.110012.00	Bushing, Governor Gear	1
47	47.050200.00	Connecting Rod	1
48	46.050005.01	Piston	1
49	2.09.004	Circlip Ø21 x Ø1	2
50	45.050003.00	Pin, Piston	1
51	46.050303.01	Ring, Oil	1
52	46.050302.01	Ring, Second Piston	1
53	46.050301.01	Ring, First Piston	1
54	2.04.004	Dowel Pin Ø12 x 20	2
55	46.030009.00	Gasket, Cylinder Head	1
56	46.080400.00	Air Guide, Lower	1
57	46.010100.00	Cylinder Head	1
58	2.15.002(F6RTC)	Spark Plug, F6RTC	1
59	2.08.014	Flange Bolt M10 x 80	4
60	46.020002.00	Gasket, Cylinder Head Cover	1
61	46.021000.00	Cylinder Head Cover	1
62	45.020001.02	Breather Tube	1
63	45.020100.00	Bolt, Cylinder Head Cover	1
64	46.041000.00	Camshaft	1
65	45.040013.00	Valve Lifter	2
66	45.040002.00	Intake Valve	1
67	45.040006.00	Exhaust Valve	1
68	46.040005.00	Push Rod	2
69	45.040015.00	Retainer, Valve Spring, Down	2
70	45.040017.00	Oil Seal, Valve	2
71	45.040003.00	Spring, Valve	2
72	23.040010.00	Bolt, Rocker Arm	2

#	Part Number	Description	Qty
73	45.040001.00	Retainer, Intake Valve Spring, Up	1
74	45.040007.00	Retainer, Exhaust Valve Spring, Up	1
75	45.040008.00	Rotator, Exhaust Valve	1
76	46.040004.00	Guide Plate, Push Rod	1
77	46.040016.00	Shaft, Rocker Arm	1
78	46.040201.00	Retainer, Rocker Arm	1
79	46.040009.00	Rocker Arm, Intake Valve	1
80	46.040018.00	Rocker Arm, Exhaust Valve	1
81	1.97.1.06	Washer Ø6	2
82	22.040012.00	Screw, Valve Adjustment	2
83	1.6177.1.06	Flange Lock Nut M6	2
84	21.040021.00	Lock Nut M6 x 0.5	2
85	2.01.007	Stud Bolt M6 x M8 x 130	2
86	46.130002.20	Gasket, Insulator	1
87	45.130001.01	Insulator, Carburetor	1
88	46.130003.00	Gasket, Carburetor	1
89	46.131000.01	Carburetor	1
90	45.130004.00	Gasket, Air Cleaner	1
91	2.06.007	Clip Ø8 x b6	3
92	1.6177.06	Flange Nut M6	3
93	46.091100.01	Base, Air Cleaner	1
94	1.5789.0633	Flange Bolt M6 x 33	1
95	46.091003.08	Element, Air Cleaner	1
96	46.091102.01	Supporter, Air Cleaner	1
97	46.091200.02	Cover, Air Cleaner	1
98	46.091600.01	Screw cap, Air Cleaner Cover	2
99	46.091000.08	Air Cleaner Assembly	1
100	46.070014.01	Pipe, Fuel Tank To Air Cleaner	1
101	24.070100.02	Fuel Tank Cap	1
102	2.12.001	Buffer Ø7.5 x 7.5	1
103	46.070300.00	Fuel Filter Component, Large	1
104	2.06.006	Clamp Ø7 x Ø1	1
105	1.6187.1.08	Nut M8	5
106	21.070600.03	Joint, Fuel Pipe	1
107	2.06.016	Clamp Ø8.7 x b8	1
108	46.071000.01	Fuel Tank	1
109	1.5789.0832	Flange Bolt M8 x 32	2
110	46.070011.00	Pipe, Fuel Tank To Fuel Valve	1
111	24.070400.00	Fuel Valve	1
112	1.16674.0512.2	Flange Bolt M5 x 12	1
113	46.070011.01	Pipe, Fuel Valve To Carburetor	1
114	46.070010.00	Fuel Tank Veil	1
115	5.1010.003.3	Ignition Switch, Red	1
116	24.070001.00	Fuel Valve Knob	1
117	1.818.0412	Bolt M4 x 12	1
118	45.110001.00	Shaft, Governor Arm	1
119	2.03.019	Washer Ø8.2 x Ø17 x 0.8	1
120	2.11.006	Oil Seal Ø7 x Ø14 x 5	1
121	45.110008.00	Pin, Shaft	1
122	45.110003.00	Arm, Governor	1
123	2.08.040	Bolt M6 x 21, Governor Arm	1
124	45.110007.00	Spring, Governor	1
125	45.110005.00	Spring, Throttle Return	1
126	45.110006.00	Rod, Governor	1
127	46.080300.00	Air Guide, Upper	1
128	24.111008.01	Sheath, Grip	1
129	2.01.005	Stud Bolt M8 x 49	2
130	46.100001.07	Gasket, Exhaust Pipe	1
131	46.101001.05	Exhaust Pipe	1
132	1.848.08	Washer Ø8	7
133	46.101000.05	Muffler Assembly	1
134	1.93.08	Lock Washer Ø8	7
135	1.6175.08	Nut M8	2
136	46.101002.05	Washer, Muffler	1
137	46.101100.05	Muffler	1
138	1.16674.0510	Flange Bolt M5 x 10	5
139	46.101202.05	Muffler Protector	1
140	46.101300.05	Muffler Screen	1
141	1.818.046	Screw M4 x 6	4
142	1.848.05	Washer Ø5	5
143	1.859.05	Lock Washer Ø5	5
144	1.5789.0612.3	Flange Bolt M6 x 12	2
145	46.040200.00	Rocker Arm Assembly	1

TROUBLESHOOTING

Problem	Cause	Solution
Engine will not start	No fuel	Add fuel
	Faulty spark plug	Replace spark plug
	Unit loaded during startup	Remove load from unit
Engine starts but runs roughly	Low oil level	Fill crankcase to the proper level
		Place chipper-shredder on a flat, level surface
	Choke in the wrong position	Adjust choke
	Throttle in wrong position	Adjust throttle
	Spark plug wire loose	Attach wire to spark plug
Engine shuts down during operation	Out of fuel	Fill fuel tank
	Low oil level	Fill crankcase to the proper level
		Place chipper-shredder on a flat, level surface
Engine cannot supply enough power or overheating	Insufficient ventilation	Check for air restriction. Move to a well ventilated area
No materials are discharged	Flail housing clogged	Stop engine immediately, disconnect spark plug, take apart flail housing to clear clog
	Deflector chute clogged	Stop engine immediately, disconnect spark plug, take apart deflector chute to clear clog
	Collection bag is full	Stop engine, disconnect spark plug, empty collection bag
Discharge rate slows or discharge material changes	Low engine power	Increase throttle
	Chipper blades, shredder blade and flail blades are dull	Stop engine, disconnect spark plug, take apart flail housing and check all blades. Sharpen if needed
Excessive vibration or unusual noise while engine is running or material is being processed	Engine power too high	Decrease throttle
	Foreign object(s) in chutes or flail housing	Stop engine immediately, disconnect spark plug, inspect all chutes and take apart flail housing to inspect for foreign object (s)
	Impeller overloaded with material	Allow impeller to run current material load through before adding more
	Material is too dry or thick for blades	Remove material immediately

For further technical support:

Technical Service

Mon – Fri 8:30 AM – 5:00 PM (PST/PDT)

Toll Free: 1-877-338-0999

tech@championpowerequipment.com

WARRANTY*

CHAMPION POWER EQUIPMENT
2 YEAR LIMITED WARRANTY

Warranty Qualifications

To register your product for warranty and FREE lifetime call center technical support please visit:

<https://www.championpowerequipment.com/register>

To complete registration you will need to include a copy of the purchase receipt as proof of original purchase. Proof of purchase is required for warranty service. Please register within ten (10) days from date of purchase.

Repair/Replacement Warranty

CPE warrants to the original purchaser that the mechanical and electrical components will be free of defects in material and workmanship for a period of two years (parts and labor) from the original date of purchase and 180 days (parts and labor) for commercial and industrial use. Transportation charges on product submitted for repair or replacement under this warranty are the sole responsibility of the purchaser. This warranty only applies to the original purchaser and is not transferable.

Do Not Return The Unit To The Place Of Purchase

Contact CPE's Technical Service and CPE will troubleshoot any issue via phone or e-mail. If the problem is not corrected by this method, CPE will, at its option, authorize evaluation, repair or replacement of the defective part or component at a CPE Service Center. CPE will provide you with a case number for warranty service. Please keep it for future reference. Repairs or replacements without prior authorization, or at an unauthorized repair facility, will not be covered by this warranty.

Warranty Exclusions

This warranty does not cover the following repairs and equipment:

Normal Wear

Products with mechanical and electrical components need periodic parts and service to perform well. This warranty does not cover repair when normal use has exhausted the life of a part or the equipment as a whole.

Installation, Use and Maintenance

This warranty will not apply to parts and/or labor if the product is deemed to have been misused, neglected, involved in an accident, abused, loaded beyond the product's limits, modified, installed improperly or connected incorrectly to any electrical component. Normal maintenance is not covered by this warranty and is not required to be performed at a facility or by a person authorized by CPE.

Other Exclusions

This warranty excludes:

- Cosmetic defects such as paint, decals, etc.
- Wear items such as filter elements, o-rings, etc.
- Accessory parts such as starting batteries, and storage covers.
- Failures due to acts of God and other force majeure events beyond the manufacturer's control.
- Problems caused by parts that are not original Champion Power Equipment parts.

When applicable, this warranty does not apply to products used for prime power in place of a utility.

Limits of Implied Warranty and Consequential Damage

Champion Power Equipment disclaims any obligation to cover any loss of time, use of this product, freight, or any incidental or consequential claim by anyone from using this product. THIS WARRANTY AND THE ATTACHED U.S. EPA and/or CARB EMISSION CONTROL SYSTEM WARRANTIES (WHEN APPLICABLE) ARE IN LIEU OF ALL OTHER WARRANTIES, EXPRESS OR IMPLIED, INCLUDING WARRANTIES OF MERCHANTABILITY OR FITNESS FOR A PARTICULAR PURPOSE.

A unit provided as an exchange will be subject to the warranty of the original unit. The length of the warranty governing the exchanged unit will remain calculated by reference to the purchase date of the original unit.

This warranty gives you certain legal rights which may change from state to state or province to province. Your state or province may also have other rights you may be entitled to that are not listed within this warranty.

Contact Information

Address

Champion Power Equipment, Inc.
12039 Smith Ave.
Santa Fe Springs, CA 90670 USA
www.championpowerequipment.com

Customer Service

Mon – Fri 8:30 AM – 5:00 PM (PST/PDT)
Toll Free: 1-877-338-0999
info@championpowerequipment.com
Fax no.: 1-562-236-9429

Technical Service

Mon – Fri 8:30 AM – 5:00 PM (PST/PDT)
Toll Free: 1-877-338-0999
tech@championpowerequipment.com
24/7 Tech Support: 1-562-204-1188

*Except as otherwise stipulated in any of the following enclosed Emission Control System Warranties (when applicable) for the Emission Control System: U.S. Environment Protection Agency (EPA) and/or California Air Resources Board (CARB).

**CHAMPION POWER EQUIPMENT, INC. (CPE),
THE UNITED STATES ENVIRONMENT PROTECTION AGENCY (U.S. EPA)
EMISSION CONTROL SYSTEM WARRANTY**

Your Champion Power Equipment (CPE) engine complies with U.S. EPA emission regulations.

YOUR WARRANTY RIGHTS AND OBLIGATIONS:

The US EPA AND CPE are pleased to explain the Federal Emission Control Systems Warranty on your 2019 small off-road engine (SORE) and engine powered equipment. New engines and equipment must be designed, built and equipped, at the time of sale, to meet U.S. EPA regulations for small off-road engines (SORE). CPE warrants the emission control system on your small off-road engine (SORE) and equipment for the period of time listed below, provided there has been no abuse, neglect, unapproved modification, or improper maintenance of your equipment.

Your emission control system may include parts such as the carburetor, fuel-injection system, the ignition system, catalytic converter and fuel lines. Also included may be hoses, belts, connectors and other emission related assemblies. Where a warrantable condition exists, CPE will repair your small off-road engine (SORE) at no cost to you including diagnosis, parts and labor.

MANUFACTURER'S EMISSION CONTROL SYSTEM WARRANTY COVERAGE:

This emission control system is warranted for two years, subject to provisions set forth below. If, during the warranty period, an emission related part on your engine is defective in materials or workmanship, the part will be repaired or replaced by CPE.

OWNER WARRANTY RESPONSIBILITIES:

As the small off-road engine (SORE) owner, you are responsible for the performance of the required maintenance listed in your Owner's Manual. CPE recommends that you retain all your receipts covering maintenance on your small off-road engine (SORE), but CPE cannot deny warranty solely for the lack of receipts or for your failure to ensure the performance of all scheduled maintenance.

As the small off-road engine (SORE) owner, you should however be aware that CPE may deny you warranty coverage if your small, off-road engine (SORE) or a part has failed due to abuse, neglect, improper maintenance or unapproved modifications.

You are responsible for presenting your small off-road engine (SORE) to an Authorized CPE service outlet or alternate service outlet as described in (3)(f.) below, CPE dealer or CPE, Santa Fe Springs, Ca. as soon as a problem exists. The warranty repairs should be completed in a reasonable amount of time, not to exceed 30 days.

If you have any questions regarding your warranty rights and responsibilities, you should contact:

Champion Power Equipment, Inc.
Customer Service
12039 Smith Ave.
Santa Fe Springs, CA 90670
1-877-338-0999
tech@championpowerequipment.com

EMISSION CONTROL SYSTEM WARRANTY

The following are specific provisions relative to your Emission Control System (ECS) Warranty Coverage.

- 1. APPLICABILITY:** This warranty shall apply to 1997 and later model year small off-road engines (SORE). The ECS Warranty Period shall begin on the date the new engine or equipment is delivered to its original, end-use purchaser, and shall continue for 24 consecutive months thereafter.
- 2. GENERAL EMISSIONS WARRANTY COVERAGE**

CPE warrants to the original, end-use purchaser of the new engine or equipment and to each subsequent purchaser that each of its small off-road engines (SORE) is:

 - 2a. Designed, built and equipped so as to conform to U.S. EPA emissions standards for spark-ignited engines at or below 19 kilowatts.
 - 2b. Free from defects in materials and workmanship that cause the failure of a warranted part to be identical in all material respects to the part as described in the engine manufacturer's application for certification for a period of two years.
- 3. THE WARRANTY ON EMISSION-RELATED PARTS WILL BE INTERPRETED AS FOLLOWS:**
 - 3a. Any warranted part that is not scheduled for replacement as required maintenance in the Owners Manual shall be warranted for the ECS Warranty Period. If any such part fails during the ECS Warranty Period, it shall be repaired or replaced by CPE according to Subsection "d" below. Any such part repaired or replaced under the ECS Warranty shall be warranted for any remainder of the ECS Warranty Period.
 - 3b. Any warranted, emissions-related part which is scheduled only for regular inspection as specified in the Owners Manual shall be warranted for the ECS Warranty Period. A statement in such written instructions to the effect of "repair or replace as necessary", shall not reduce the ECS Warranty Period. Any such part repaired or replaced under the ECS Warranty shall be warranted for the remainder of the ECS Warranty Period.
 - 3c. Any warranted, emissions-related part which is scheduled for replacement as required maintenance in the Owner's Manual shall be warranted for the period of time prior to the first scheduled replacement point for that part. If the part fails prior to the first scheduled replacement, the part shall be repaired or replaced by CPE according to Subsection "d" below. Any such emissions-related part repaired or replaced under the ECS Warranty, shall be warranted for the remainder of the ECS Warranty Period prior to the first scheduled replacement point for such emissions-related part.
 - 3d. Repair or replacement of any warranted, emissions-related part under this ECS Warranty shall be performed at no charge to the owner at a CPE Authorized Service Outlet.
 - 3e. The owner shall not be charged for diagnostic labor which leads to the determination that a part covered by the ECS Warranty is in fact defective, provided that such diagnostic work is performed at a CPE Authorized Service Outlet.
 - 3f. CPE shall pay for covered emissions warranty repairs at non-authorized service outlets under the following circumstances:
 - i. The service is required in a population center with a population over 100,000 according to U.S. Census 2000 without a CPE Authorized Service Outlet AND
 - ii. The service is required more than 100 miles from a CPE Authorized Service Outlet. The 100 mile limitation does not apply in the following states: Alaska, Arizona, Colorado, Hawaii, Idaho, Montana, Nebraska, Nevada, New Mexico, Oregon, Texas, Utah and Wyoming.
 - 3g. CPE shall be liable for damages to other original engine components or approved modifications proximately caused by a failure under warranty of an emission-related part covered by the ECS Warranty.
 - 3h. Throughout the ECS Warranty Period, CPE shall maintain a supply of warranted emission-related parts sufficient to meet the expected demand for such emission-related parts.
 - 3i. Any CPE Authorized and approved emission-related replacement part may be used in the performance of any ECS Warranty maintenance or repair and will be provided without charge to the owner. Such use shall not reduce CPE's warranty obligation.
 - 3j. Unapproved add-on or modified parts may not be used to modify or repair a CPE engine. Such use voids this ECS Warranty and shall be sufficient grounds for disallowing an ECS Warranty claim. CPE shall not be liable hereunder for failures of any warranted parts of a CPE engine caused by the use of such an unapproved add-on or modified part.

EMISSION-RELATED PARTS INCLUDE THE FOLLOWING: (using those portions of the list applicable to the engine)

Systems covered by this warranty	Parts Description
Fuel Metering System	Fuel regulator, Carburetor and internal parts
Air Induction System	Air cleaner, Intake manifold
Ignition System	Spark plug and parts, Magneto ignition system
Exhaust System	Exhaust manifold, catalytic converter
Miscellaneous Parts	Tubing, Fittings, Seals, Gaskets, and Clamps associated with these listed systems.
Evaporative Emissions	Fuel Tank, Fuel Cap, Fuel Line (for liquid fuel and fuel vapors), Fuel Line Fittings, Clamps, Pressure Relief Valves, Control Valves, Control Solenoids, Electronic Controls, Vacuum Control Diaphragms, Control Cables, Control Linkages, Purge Valves, Gaskets, Vapor Hoses, Liquid/Vapor Separator, Carbon Canister, Canister Mounting Brackets, Carburetor Purge Port Connector

TO OBTAIN WARRANTY SERVICE:

You must take your CPE engine or the product on which it is installed, along with your warranty registration card or other proof of original purchase date, at your expense, to any Champion Power Equipment dealer who is authorized by Champion Power Equipment, Inc. to sell and service that CPE product during his normal business hours. Alternate service locations defined in Section (3)(f.) above must be approved by CPE prior to service. Claims for repair or adjustment found to be caused solely by defects in material or workmanship will not be denied because the engine was not properly maintained and used.

If you have any questions regarding your warranty rights and responsibilities, or to obtain warranty service, please write or call Customer Service at Champion Power Equipment, Inc.

Champion Power Equipment, Inc.
12039 Smith Ave.
Santa Fe Springs, CA 90670
1-877-338-0999
Attn.: Customer Service
tech@championpowerequipment.com