



OPERATOR'S MANUAL

MODEL #201312
27-TON GAS POWERED LOG SPLITTER



ACTIVATE YOUR WARRANTY

by registering your product:
championpowerequipment.com

SERIAL NO.



  **1-877-338-0999**

or visit championpowerequipment.com

READ AND SAVE THIS MANUAL. This manual contains important safety precautions which should be read and understood before operating the product. Failure to do so could result in serious injury. This manual should remain with the product.
Specifications, descriptions and illustrations in this manual are as accurate as known at the time of publication, but are subject to change without notice.

TABLE OF CONTENTS

Introduction	3
Safety Definitions	3
Important Safety Instructions	4
Fuel Safety	6
Training Instructions	7
Preparation	7
Operation	8
Maintenance	8
Safety and Dataplate Labels	9
Safety Symbols	10
Operation Symbols	12
Quickstart Label Symbols	12
Controls and Features	13
Log Splitter	13
Engine	14
Parts Included	15
Assembly	16
Open Shipping Crate	16
1) Install the Wheels	16
2) Install the Tow Bar	16
3) Install the Beam	16
4) Install the Engine	17
5) Install the Hoses and Hydraulic Filter	17
6) Install the Log Catcher	18
Add Engine Oil	19
Add Fuel	19
Add Hydraulic Oil	20
Before Each Use Inspect the Log Splitter	21
Changing Beam from Horizontal to Vertical Orientation	22
Towing Log Splitter Safety	23
Log Splitter Location	23

Operation	24
Starting the Engine	24
Stopping the Engine	25
Log Splitter Operation	25
Operation at High Altitude	26
Maintenance	26
Cleaning the Log splitter	27
Changing the Engine Oil	27
Cleaning and Adjusting the Spark Plug(s)	27
Cleaning the Air Filter	27
Changing the Hydraulic Oil	28
Maintenance Schedule	29
Storage	30
Log Splitter Storage	30
Engine Stored for Less than 30 Days	30
Engines Stored for Over 30 Days	30
Specifications	31
Log Splitter Specifications	31
Engine Specifications	31
Oil Specifications	31
Hydraulic Oil System	31
Fuel Specifications	31
Spark Plug Specifications	31
Valve Specifications	31
Important Message About Temperature	31
Troubleshooting	32

 FOR PARTS BREAKDOWN

Search by model number at
championpowerequipment.com

INTRODUCTION

Congratulations on your purchase of a Champion Power Equipment (CPE) product. CPE designs, builds, and supports all of our products to strict specifications and guidelines. With proper product knowledge, safe use, and regular maintenance, this product should bring years of satisfying service.

Every effort has been made to ensure the accuracy and completeness of the information in this manual at the time of publication, and we reserve the right to change, alter and/or improve the product and this document at any time without prior notice.

Since CPE highly values how our products are designed, manufactured, operated and are serviced, and also highly value your safety and the safety of others, we would like you to take the time to review this product manual and other product materials thoroughly and be fully aware and knowledgeable of the assembly, operation, dangers and maintenance of the product before use. Fully familiarize yourself, and make sure others who plan on operating the product fully familiarize themselves too, with the proper safety and operation procedures before each use. Please always exercise common sense and always err on the side of caution when operating the product to ensure no accident, property damage, or injury occurs. We want you to continue to use and be satisfied with your CPE product for years to come.

When contacting CPE about parts and/or service, you will need to supply the complete model and serial numbers of your product. Transcribe the information found on your product's nameplate label to the table below

CPE TECHNICAL SUPPORT TEAM
1-877-338-0999
MODEL NUMBER
201312
SERIAL NUMBER
DATE OF PURCHASE
PURCHASE LOCATION

SAFETY DEFINITIONS

The purpose of safety symbols is to attract your attention to possible dangers. The safety symbols, and their explanations, deserve your careful attention and understanding. The safety warnings do not by themselves eliminate any danger. The instructions or warnings they give are not substitutes for proper accident prevention measures.

DANGER

DANGER indicates a hazardous situation which, if not avoided, will result in death or serious injury.

WARNING

WARNING indicates a hazardous situation which, if not avoided, could result in death or serious injury.

CAUTION

CAUTION indicates a hazardous situation which, if not avoided, could result in minor or moderate injury.

NOTICE

NOTICE indicates information considered important, but not hazard-related (e.g., messages relating to property damage).

IMPORTANT SAFETY INSTRUCTIONS

⚠ WARNING

Cancer and Reproductive Harm – www.P65Warnings.ca.gov

⚠ DANGER

Engine exhaust contains carbon monoxide, a colorless, odorless, poison gas. Breathing carbon monoxide will cause nausea, dizziness, fainting or death. If you start to feel dizzy or weak, move to fresh air immediately.

Operate log splitter ONLY outdoors in a well ventilated area.

DO NOT operate the log splitter inside any building, including garages, basements, crawlspaces, sheds, or enclosure.

DO NOT allow exhaust fumes to enter a confined area through windows, doors, vents or other openings.

⚠ DANGER

Using an engine indoors **CAN KILL YOU IN MINUTES**. Engine exhaust contains carbon monoxide. This is a poison you cannot see or smell.

NEVER use inside a home or garage, **EVEN IF** doors and windows are open.

ALWAYS use **OUTSIDE** and far away from windows, doors, and vents.



⚠ WARNING

Although the log splitter contains a spark arrester, maintain a minimum distance of 5 ft. (1.5 m) from dry vegetation to prevent fires.

⚠ WARNING

Sparks can result in fire or electrical shock.

When servicing the engine:

Disconnect the spark plug wire and place it where it cannot contact the plug.

DO NOT check for spark with the plug removed.

Use only approved spark plug testers.

⚠ WARNING

Running engines produce heat. Severe burns can occur on contact. Combustible material can catch fire on contact.

DO NOT touch hot surfaces.

Avoid contact with hot exhaust gases.

Allow equipment to cool before touching.

Maintain at least 3 ft. (91.4 cm) of clearance on all sides to ensure adequate cooling.

⚠ WARNING

Crush Hazard

Wedge can cut through skin and break bones. Keep all limbs away from wedge and endplate.

⚠ WARNING

Projectile Hazard

Pieces of log may be ejected from the log splitter while operating. Always wear ANSI approved safety glasses when operating. Be alert.

⚠ WARNING

Keep operator work zone clear of debris while working to ensure safe footing.

⚠ DANGER

Skin Injection Hazard.

Hydraulic oil escaping under high pressure can penetrate skin and cause serious bodily injury. In the event that hydraulic oil may penetrate the skin and to avoid serious infections such as gangrene, seek proper medical attention immediately.

⚠ WARNING

Always make sure all hydraulic oil connections are tightly secured and hydraulic hoses are in good condition, no cuts, tears, or damage before applying pressure to the system.

⚠ WARNING

Always keep hands and body parts away from nozzles or pinholes that could eject hydraulic oil under high pressure in the event of an oil leak.

NEVER use bare hands to search for leaks. Leaks can be detected by using cardboard, paper or scrap wood over the suspected area.

⚠ WARNING**Towing Hazard**

Always check with your local municipality, state or provincial regulations regarding towing, lights and licensing before towing your log splitter on public roads.

BEFORE towing, review all safety warnings in your towing vehicle manual. Drive safely. Be aware of the added length of the log splitter.

NEVER ride or transport cargo on the log splitter.

DO NOT exceed the maximum 45 MPH (72 KM/H) towing speed.

⚠ WARNING

Before removing the pin installed on the front support leg, make sure the hitch is installed onto the vehicle. Releasing the pin before will cause support leg to slide up and possibly cause injury.

⚠ WARNING

Rapid retraction of the starter cord will pull hand and arm towards the engine faster than you can let go. Broken bones, fractures, bruises or sprains could result.

Unintentional startup can result in entanglement, traumatic amputation or laceration.

When starting engine, pull the starter cord slowly until resistance is felt and then pull rapidly to avoid kickback.

⚠ CAUTION

Parts of the hydraulic circuit (cylinder, pump, valve-body, hoses) can become very hot during operation.

⚠ WARNING

Improper treatment or use of the log splitter can damage it, shorten its life and void your warranty.

ALWAYS use the log splitter for its intended use.

ALWAYS operate only on level surfaces.

DO NOT expose log splitter to excessive moisture, dust, or dirt.

DO NOT allow any material to block the cooling slots.

DO NOT use the engine if:

- Equipment sparks, smokes or emits flames
- Equipment vibrates excessively

Fuel Safety

⚠ DANGER

GASOLINE AND GASOLINE VAPORS ARE HIGHLY FLAMMABLE AND EXPLOSIVE.

Fire or explosion can cause severe burns or death.

Gasoline and gasoline vapors:

- Gasoline vapors are highly flammable and explosive.
- Gasoline vapors can cause a fire or explosion if ignited.
- Gasoline is a liquid fuel and the resulting gasoline vapors can ignite and cause a fire or explosion.
- Gasoline is a skin irritant and needs to be cleaned up immediately if spilled on skin or clothes.
- Gasoline has a distinctive odor, this will help detect potential leaks quickly.
- In any petroleum gas fire, flames should not be extinguished unless by doing so the fuel supply valve can be turned OFF. This is because if a fire is extinguished and a supply of fuel is not turned OFF, then an explosion hazard could be created.
- Gasoline vapors expand and contract with ambient temperatures. Never fill the gasoline tank past the red FULL indicator on the fuel filter, as gasoline vapors need room to expand if temperatures rise.

⚠ WARNING

When adding or removing gasoline:

Do not light or smoke cigarettes.

Always stop the engine and allow to cool for a minimum of two minutes before refueling.

Always loosen gasoline cap slowly to release vapor pressure and to keep fuel from escaping around the gasoline cap.

Always replace and tighten the gasoline cap securely after fueling.

Never remove the gasoline cap or add gasoline while the engine is running or when the engine is hot.

Always fill or drain gasoline outdoors in a well-ventilated area.

Do not pump gasoline directly into the log splitter at the gas station.

Always store gasoline in an EPA/CARB compliant container or to transfer the gasoline to the log splitter.

Do not overfill the gasoline tank.

Always keep gasoline away from sparks, open flames, pilot lights, heat and other sources of ignition.

⚠ WARNING

When starting the log splitter:

Do not attempt to start a damaged log splitter.

Always check that the gasoline cap, air filter, spark plug, fuel lines and exhaust system are properly in place.

Always allow spilled gasoline to evaporate fully before attempting to start the engine.

Always be certain that the log splitter is resting firmly on level ground.

⚠ WARNING

When operating the log splitter:

Do not move or tip the log splitter during operation.

⚠ WARNING

When transporting or servicing the log splitter:

Always check that the fuel valve is in the OFF position and the gasoline tank is empty.

Disconnect the spark plug wire.

⚠ WARNING

When storing the log splitter:

Store away from sparks, open flames, pilot lights, heat and other sources of ignition.

Do not store log splitter or gasoline near furnaces, water heaters, or any other appliances that produce heat or have automatic ignitions.

⚠ DANGER

Never place a gasoline container, gasoline tank, or any combustible material in the path of the exhaust stream during operation of the engine.

⚠ WARNING

Never use a gasoline container, gasoline tank, or any other fuel item that is broken, cut, torn or damaged.

Training Instructions

⚠ CAUTION

1. Read the Operator's Manual completely before attempting to use this log splitter.
2. Do not allow anyone to operate your log splitter who has not read the Operator's Manual or has not been instructed on the safe use of the log splitter.
3. Never allow children or untrained adults to operate this machine.
4. Accidents occur when more than one (1) person operates the log splitter. If a helper is assisting in loading logs to be split, never actuate controls until helper is clear of the area.
5. Never transport cargo on the log splitter or ride on the machine.
6. High fluid pressures develop in hydraulic log splitters. Pressurized hydraulic fluid escaping through a pin hole opening can puncture skin and cause severe infections or blood poisoning. Therefore, these instructions should be followed at all times.
 - Do not operate the unit with frayed, kinked, cracked or damaged hoses, fittings, or tubing.
 - Stop the engine and relieve hydraulic system pressure before changing or adjusting fittings, hoses, tubing, or other system components.
 - Do not adjust the pressure settings of the pump or valve.
 - Do not check for leaks with your hand. Leaks can be detected by passing cardboard or wood over the suspected area. Look for discoloration. If injured by escaping fluid, see a doctor at once. Serious infection or reaction can develop if proper medical treatment is not administered immediately.
7. Keep the operator zone and adjacent area clear for safe, secure footing.
8. Your log splitter is equipped with an internal-combustion engine and is not intended for use near any unapproved regulated and controlled forest, brush, or grass covered land. Always check with your local municipality, state and federal regulations prior to use.
9. Log splitters should be used only for splitting wood.

Preparation

⚠ CAUTION

1. Be thoroughly familiar with all controls and with proper use of the equipment.
2. Safety Gear:
 - Always wear safety shoes or heavy boots when operating the machine.
 - Always wear safety glasses or goggles when operating the machine.
 - Never wear jewelry or loose-fitting clothing that might become entangled in moving or rotating parts of the machine.
3. Make sure the log splitter is on a level surface. Block tires and ensure support leg is secure to prevent unintended movement of the log splitter during operation.
 - Always operate the splitter from the manufacturer's indicated operator zone.
4. Logs to be split on ram-type units should be cut as squarely as possible.

Operation

⚠ CAUTION

1. Before starting this log splitter, review all safety instructions. Failure to follow these instructions may result in serious injury to the operator or bystanders.
2. Be sure to confirm all hose clamp connections are tight before each use. It is possible for clamp connections to vibrate loose over time.
3. Never leave the machine unattended with the power source operating.
4. Never operate the machine when under the influence of alcohol, drugs or medication.
5. The machine owner should instruct all operators in safe log splitter operation.
6. Always operate the log splitter with all safety equipment in place and all controls properly adjusted for safe operation.
7. Always operate the log splitter at manufacturer's recommended speed.
8. Always keep hands and feet clear of moving parts.
9. When loading a ram-type log splitter, place your hands on the sides of the log, not the ends. Never place your hands or any part of your body between a log and any part of the log splitter.
10. On ram-type log splitters, never attempt to split more than one (1) log at a time unless the ram has been fully extended and a second log is needed to complete the separation of the first log.
11. On ram-type log splitters on which the logs are not cut square, the longest portion of the log should be rotated down and the most square end placed against the ram.
12. Always split logs with the grain of the wood.
13. Never split perpendicular to the grain of the wood.
14. Use only your hand to operate the log splitter controls.
15. Never add fuel to a running or hot engine.
16. Always turn the engine off and wait a minimum of 2 minutes to cool engine before removing gasoline cap prior to refueling.

Maintenance

⚠ CAUTION

1. Always shut off the power source while repairing or adjusting the log splitter except as recommended by the manufacturer.
2. Clean debris and chaff from the engine cylinder, cylinder head fins, recoil starter cover, and muffler areas. The engine is equipped with a spark arrestor muffler, clean and inspect it regularly (follow manufacturer's service instructions). Replace, if damaged.
3. Check to be sure all nuts and bolts are tight to assure the equipment is in safe working condition before next operation.

Safety and Dataplate Labels

These labels warn you of potential hazards that can cause serious injury. Read them carefully.



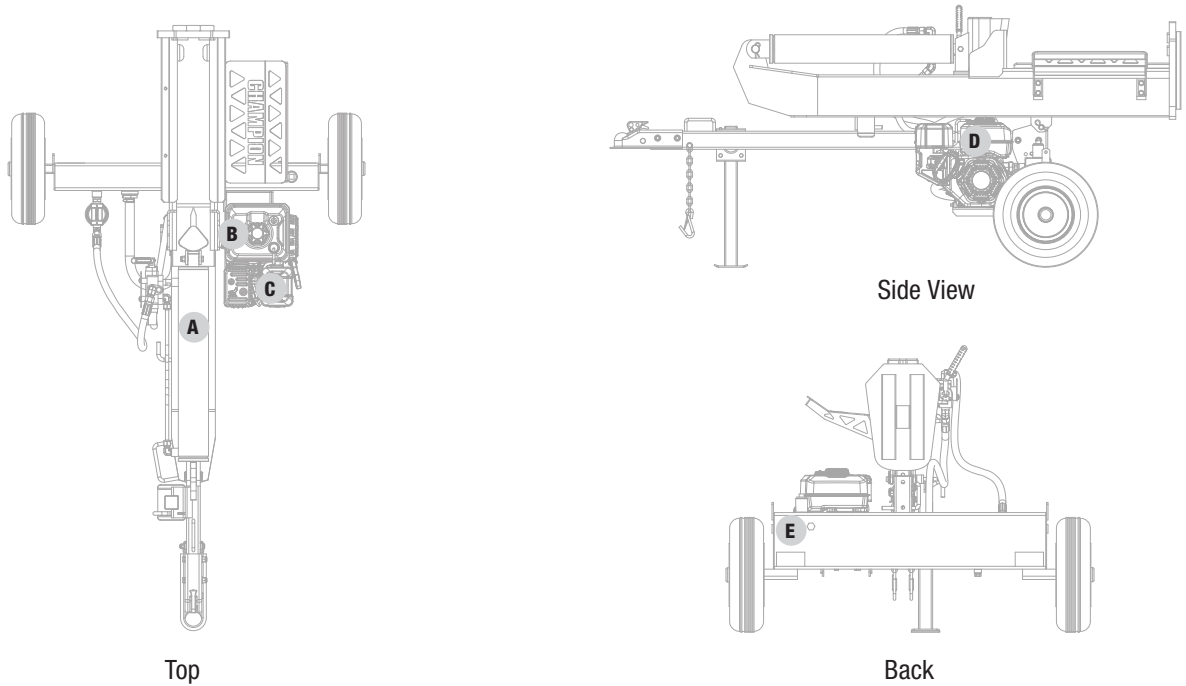





If a label comes off or becomes hard to read, contact Technical Support Team for possible replacement.











	LABEL	DESCRIPTION
A		Safety Symbols
B		Fuel
C		Hot Surface
D		Fuel valve and gasoline tank
E		Dataplate

Safety Symbols

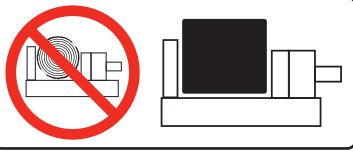
Some of the following symbols may be used on this product. Please study them and learn their meaning. Proper interpretation of these symbols will allow you to more safely operate the product.

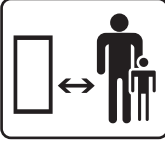
SYMBOL	MEANING
	<p>Read Operator's Manual. To reduce the risk of injury, user must read and understand operator's manual before using this product.</p>
	<p>Eye and Ear Protection. Always wear safety goggles or safety glasses with side shields, and as necessary a full face-shield as well as full ear protection when operating this product.</p>
	<p>Footwear. Always wear safety shoes or heavy boots when operating the machine.</p>
	<p>Gloves. Always wear nonslip, heavy-duty protective gloves when operating this product.</p>
	<p>Safety Alert. Precautions that involve your safety.</p>
	<p>Risk of Fire. Fuel and its vapors are extremely flammable and explosive. Fire can cause severe burns or death. Do not add fuel while the product is operating or still hot.</p>
	<p>Skin Injection Hazard. High pressure hydraulic oil can inject under your skin. Make sure all fittings are tightly secure before applying pressure. Relieve system pressure before servicing.</p>
	<p>Always keep hands away from the wedge and the ram. Moving parts can crush or cut.</p>

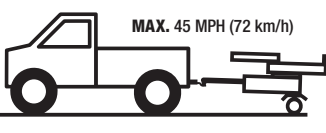
SYMBOL	MEANING
	<p>Always keep feet away from the wedge and the ram. Moving parts can crush or cut.</p>
	<p>Hot Surface. To reduce the risk of injury or damage, avoid contact with any hot surface</p>
	<p>Open Flame alert. Fuel and its vapors are extremely flammable and explosive. Keep fuel away from smoking, open flames, sparks, pilot lights, heat, and other ignition sources.</p>
	<p>Hold logs on sides when loading. Keep hands and feet away from cylinder, wedge, and partially split logs.</p>
	<p>Never place hands or any part of the body between a log and any part of the log splitter. Do not split logs against the grain. Split logs end to end in the direction of the grain only.</p>
	<p>Toxic Fumes. The engine exhaust from this product contains chemicals known to the state of California to cause cancer and birth defects and other reproductive harm.</p> <p>Risk of Asphyxiation. This engine emits carbon monoxide, an odorless, colorless poison gas. Breathing carbon monoxide can cause nausea, fainting or death. Always use in a well ventilated area.</p>
	<p>Clearance. Keep all objects including others at least 10 feet (3m) from this machine. Only one person should operate the log splitter and load the logs</p>
	<p>Never operate on an incline. Make sure the log splitter is on a level surface. Block tires and ensure support leg is secure to prevent unintended movement of the log splitter during operation.</p>
	<p>DO NOT exceed the maximum 45 MPH (72 KM/H) towing speed.</p> <p>Always check all local, state or provincial regulations regarding towing, licensing and lights before towing your log splitter. Review towing safety warnings in your towing vehicle manual.</p> <p>Any modifications required to meet these laws are the responsibility of the purchaser.</p>

Operation Symbols

Some of the following symbols may be used on this product. Please study them and learn their meaning. Proper interpretation of these symbols will allow you to more safely operate the product.

SYMBOL	MEANING
	STOP or OFF
	Fuel/Gasoline Valve ON/OFF
	Choke
	Run

SYMBOL	MEANING
	Fuel Gauge: Full
	Fuel Gauge: Empty

Quickstart Label Symbols

Some of the following symbols may be used on this product. Please study them and learn their meaning. Proper interpretation of these symbols will allow you to more safely operate the product.

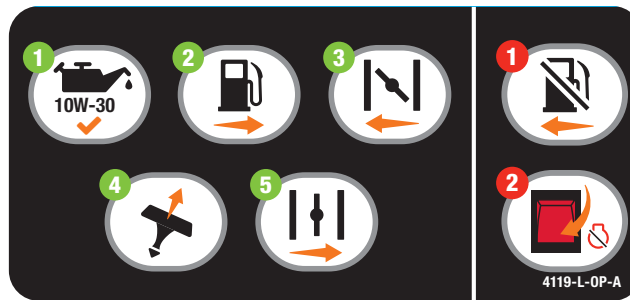

Starting the Engine

⚠ DANGER

Move log splitter outside and far away from windows, doors and intake ventilation covers.

1. **Check oil level.**
Recommended oil is 10W-30.
2. Turn the **fuel valve** to “ON” position.
3. Move **choke lever** to “CHOKE” position.
4. Pull the **recoil cord**.
5. Move the **choke lever** to “RUN” position.

Stopping the Engine

In an emergency, turn the engine switch to the “OFF” position.

Under normal operation:

1. Turn the **fuel valve** to the “OFF” position.
2. Let the engine run until fuel starvation has stopped the engine. This usually takes few minutes.

Important: Always ensure that the **fuel valve** is in the “OFF” position when the engine is not in use.

CONTROLS AND FEATURES

Read this operator's manual before operating your log splitter. Familiarize yourself with the location and function of the controls and features. Save this manual for future reference.

Log Splitter

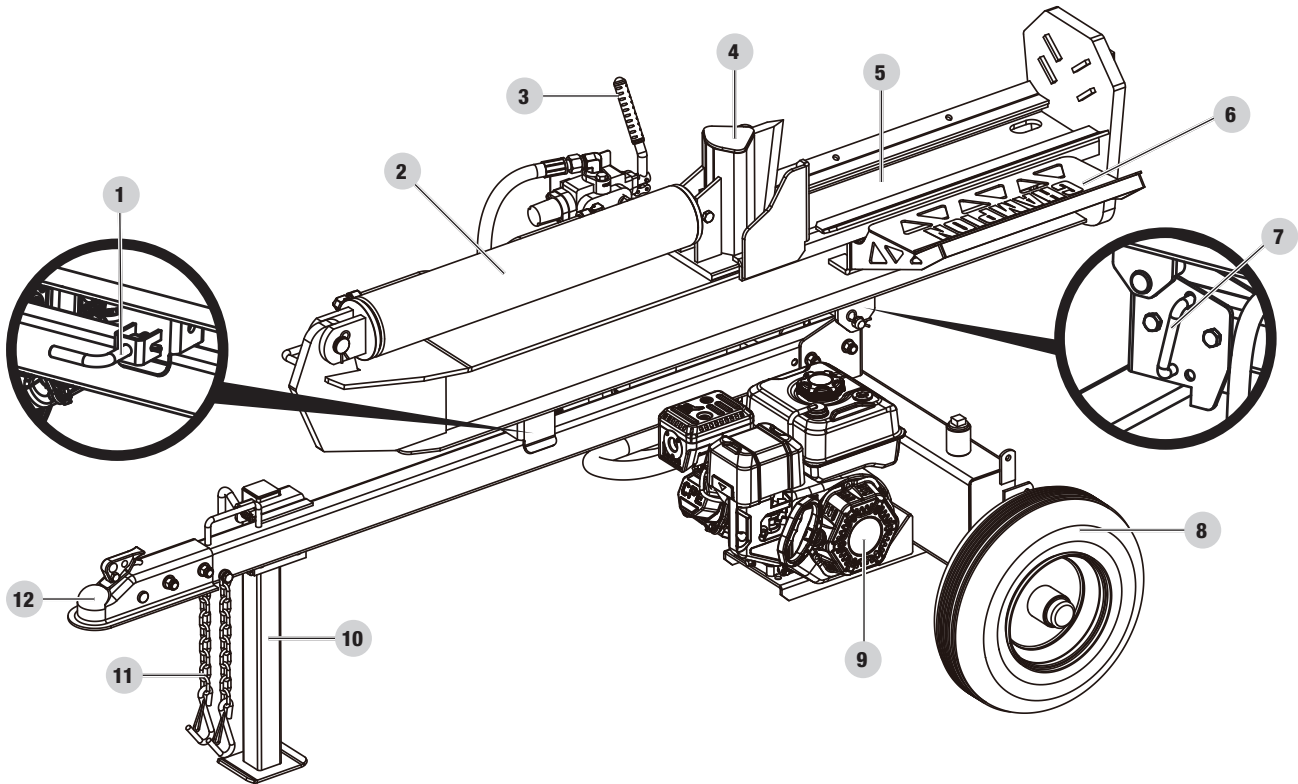

1. **Auto-Lock Horizontal Beam Lock** – Secures the beam in the horizontal position.
2. **Hydraulic Cylinder** – 4.8 in. bore (12 cm) × 23 in. (58.4 cm) stroke. MAX to 3600 psi.
3. **Control Valve Handle** – Controls the movement of the cutting wedge.
4. **Wedge**
5. **Log Cradle** – Prevents logs from rolling off beam.
6. **Log Catchers**
7. **Quick-Lock Vertical Beam Lock** – Secures the beam in the vertical position.
8. **Tires** – Maximum travel speed is 45 MPH (72 KM/H).
9. **Engine** – 224cc, OHV.
10. **Support Leg** – Supports log splitter while operating. Raise leg for towing.
11. **Safety Chains** – For use while towing.
12. **2 in. (5.1 cm) Ball Coupler** – For towing the log splitter behind your vehicle.

Engine

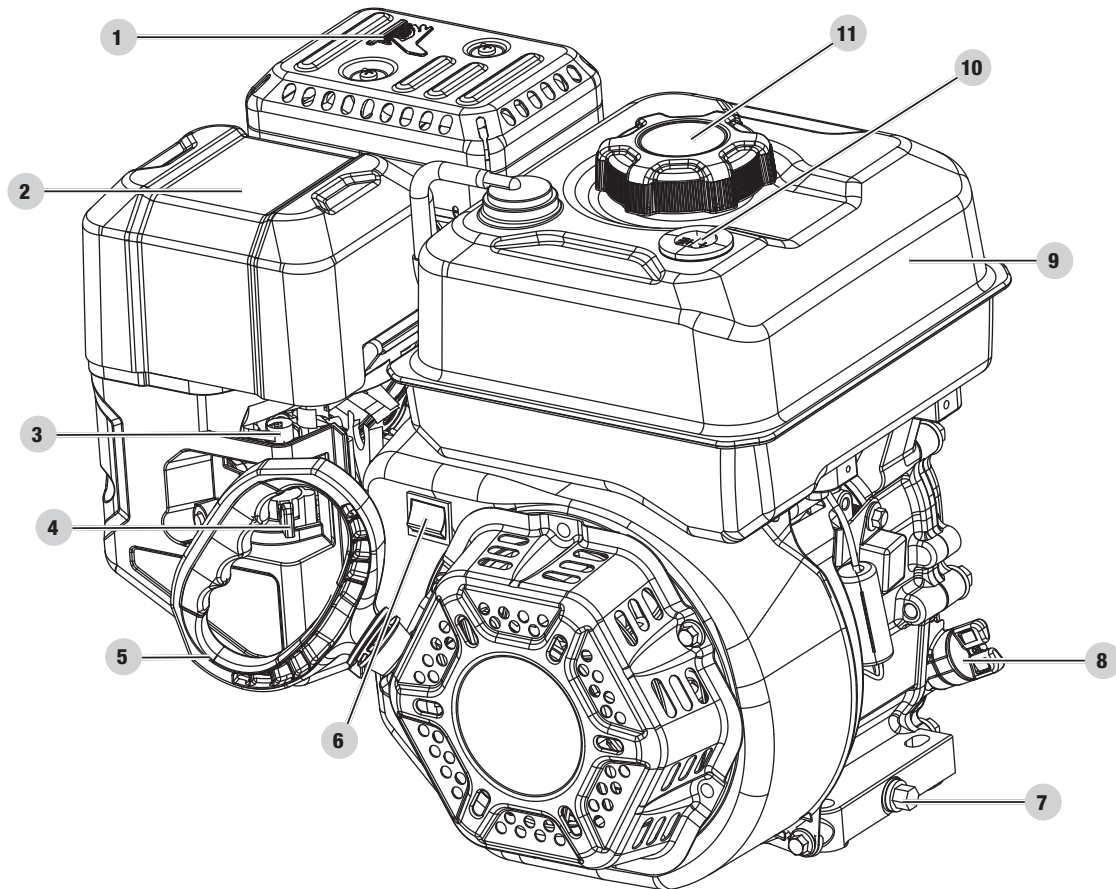

- | | |
|--|---|
| 1. Muffler | 6. Engine Switch – Used to STOP the engine. |
| 2. Air Filter – Protects the engine by filtering dust and debris from the intake air. | 7. Oil Drain Bolt – Used to drain the oil from the engine. |
| 3. Choke – Used to start the engine. | 8. Oil Fill Cap/Dipstick – Used to check and fill oil level. |
| 4. Fuel Valve – Used to turn fuel supply on and off to engine. | 9. Gasoline Tank – 0.82 gal. (3.1 L) |
| 5. Recoil Starter – Used to manually start the engine. | 10. Gasoline Gauge |
| | 11. Fuel Cap – Remove to add fuel. |

Parts Included

Part	Part Qty.	Hardware Needed	Hardware Qty.	Tool Needed
Wheels	2	Castle Nut	2	1x 30mm open-end wrench
		Cotter Pin Ø4 × 32	2	Needle nose pliers
		Axle Cap	2	Mallet
Tow Bar	1	Bolt M12x80	2	1x 18mm wrench or socket
		Nut M12	2	1x 19mm wrench or socket
		Flat Washer Ø12	2	
Beam	1	Hitch Pin	1	
		R-Pin	1	
Engine	1	Bolt M8x40	4	1x 13mm wrench
		Lock Nut M8	4	1x 14mm wrench
		Flat Washer Ø8	4	
Suction Hose	1	Spring Loaded Hose Clamp	2	Clamp Tool
High Pressure Hose	1	"O" Ring Ø10 x 2.65	1	1x 27mm open-end wrench
Oil Return Hose	1			1x 27mm open-end wrench
Log Catcher	1	Bolt M10x20	4	1x 16mm wrench or socket
		Lock Washer Ø10	4	
		Flat Washer Ø10	4	

Accessories

- Engine Oil
- Oil Funnel
- Spark Plug Wrench

ASSEMBLY

If your log splitter is already assembled, skip the assembly instructions in this manual.

If unassembled, please read and follow these instructions.

If you have any questions regarding the assembly of your log splitter, call our Technical Support Team at 1-877-338-0999. Please have your serial number and model number available.

Open Shipping Crate

1. Set the shipping crate on a solid, flat surface
2. Carefully cut the shipping bands and remove lid of shipping crate.
3. Locate all hardware before beginning assembly.

1) Install the Wheels

1. Remove the two plastic shipping caps from the wheel hubs.
2. Slide the wheel (A) onto the axle.
3. Be sure the tire valve stem is facing out.
4. Thread the castle nut (B) on the axle and tighten by hand. Use a wrench to tighten another ¼ turn.
5. Spin the wheel (A) to distribute the bearing grease.
6. Loosen the castle nut (B) and re-tighten by hand.
7. Install the cotter pin (C) through the axle and castle nut.
8. Wheel (A) should spin freely but when grasped on both sides, should not move from side to side.
9. Install the axle cap (D) using a soft-faced mallet or hammer and wood block.
10. Repeat for the other wheel.

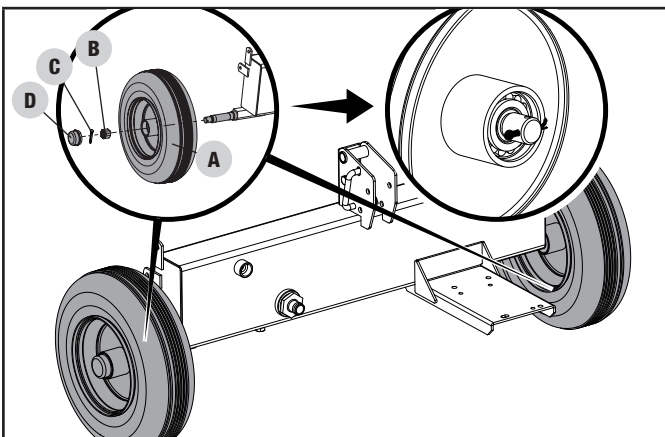

NOTICE

Keep dirt and debris away from the wheel bearings during assembly.

CAUTION

Over-tightening the castle nut will cause the bearings to run hot and fail prematurely.

2) Install the Tow Bar

Attach the tow bar to the bracket on top of the hydraulic oil tank with two M12 × 80 bolts (A), Ø12 flat washers (B) and M12 lock nuts (C).

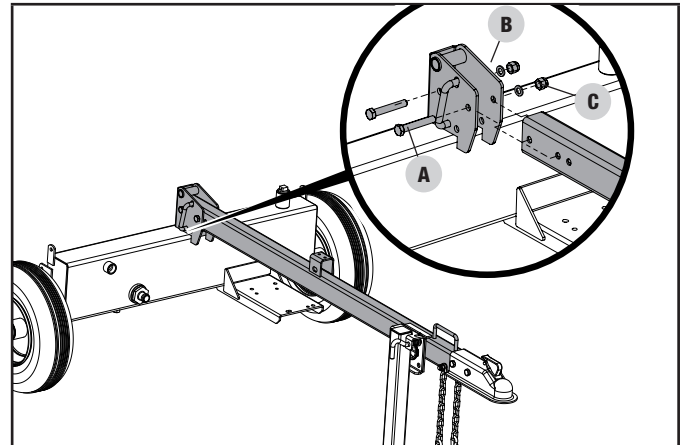

3) Install the Beam

1. Stand the beam vertical on the foot plate.
2. Roll the tank into position so the pivot holes of the tank and beam are aligned.
3. Insert the Pin (A) and secure it with the R-pin (B).

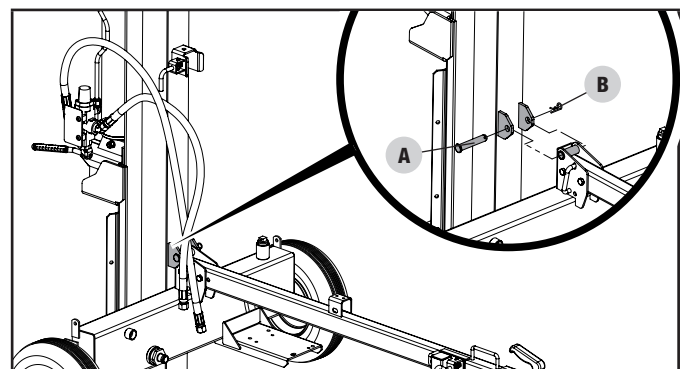

WARNING

The beam is extremely heavy and should always be handled with 2 or more people. DO NOT try and lift or handle the beam without assistance.

4) Install the Engine

1. Place the engine on the engine mounting platform with the recoil cover facing outward towards the wheel and align the 4 holes on the engine base with the holes in the engine platform.

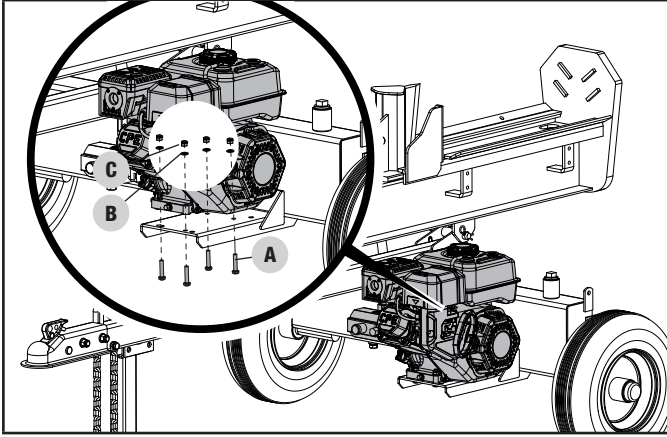

2. Install a M8 × 40 bolt (A) up through the hole on the engine platform and through the hole on the engine base.
3. Place a washer (B) on the M8 × 40 bolt (A) and thread a M8 nylon lock nut (C) onto the bolt and tighten securely. Tighten to 8 lbf-ft – 10.3 lbf-ft (12-14 Nm) or fully, then a 1/4 turn further.
4. Repeat steps 2 and 3 for the remaining bolts, washers and lock nuts.

5) Install the Hoses and Hydraulic Filter

⚠ CAUTION

Red shipping plugs must be removed from hydraulic pump prior to installing hoses.

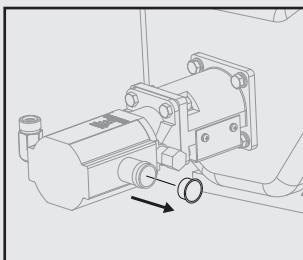

Hydraulic pump may contain residual oil from testing procedures during production. We recommend using an oil tray under the pump before removing the shipping plugs.

🗨 NOTICE

Oil Inlet (High Pressure) and Oil Return Hoses

Some hoses may be preassembled by the factory, check your hoses per below instructions to ensure proper assembly.

- These hoses are black and have swivel nuts on both ends.
- The Oil Inlet Hose sends hydraulic oil from the pump to the control valve/cylinder.
- The Oil Return Hose returns hydraulic oil from the control valve/cylinder to the tank.
- Hose connections do NOT require thread seal tape. The O-ring seals against the face of the fittings on the pump and hose.

Suction Hose

- This is the clear hose that connects the hydraulic tank to the pump inlet.
- Secure both ends of hose with hose clamps.

Suction Hose

1. Using the provided spring loaded hose clamps, connect one end of the clear oil hose (A) to the hydraulic oil tank (B) and the other end to the pump inlet on the pump (B). Using a pair of pliers, squeeze the tabs on the spring loaded hose clamps together to open them up and slide over the end of the clear suction hose and mounting fitting and release the pliers to lock the clamps into place.

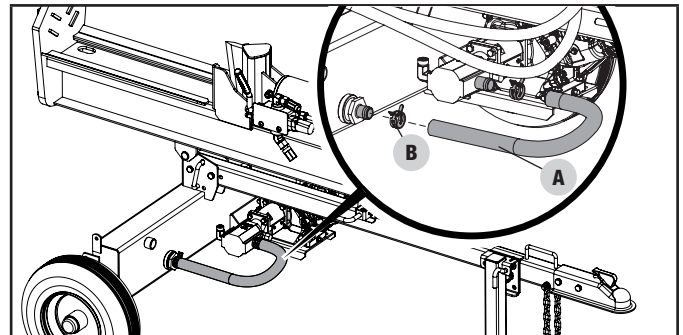

Hydraulic Filter

- The filter housing fitting that has thread sealant tape will need to be inserted and threaded into the hole on the hydraulic tank as shown here. Insert the fitting into the threaded hole and rotate clockwise until tight. The filter should be oriented downward so that it does not extend above the hydraulic tank.

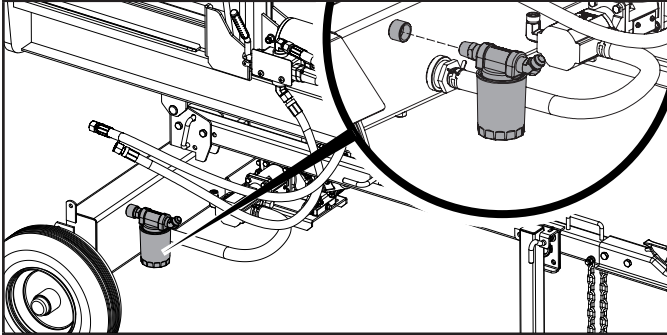

Oil Inlet (High Pressure) Hose

- Place the provided o-ring into the pump outlet fitting (C) as shown. Make sure the o-ring is properly seated in the inner groove of the fitting.
- Thread the loose end of the high pressure hydraulic hose (D) onto the pump outlet (C).
- Securely tighten the hose fitting with a 27mm wrench. Tighten to 52 lbf-ft - 66 lbf-ft (71-90 Nm).

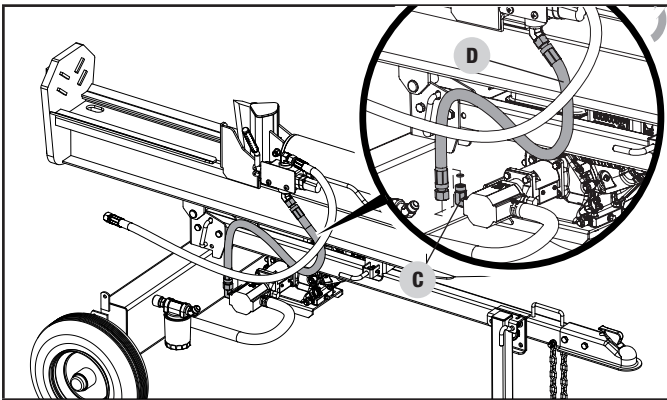

Oil Return (Low Pressure) Hose

- Thread the loose end of the low pressure hydraulic hose (E) onto the tapered hydraulic fitting on the hydraulic fluid tank (F). This hose fitting will only fit on this fitting to ensure correct connection.

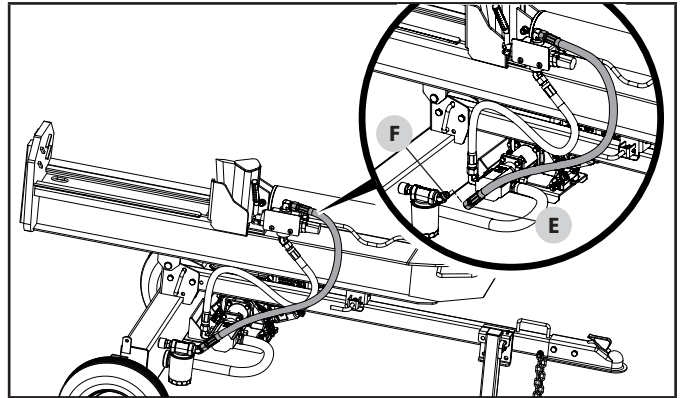

- Securely tighten the fitting with a 27mm wrench. Tighten to 52 lbf-ft - 66 lbf-ft (71-90 Nm). Make sure the fitting, when fully tightened is angled upward as shown.

6) Install the Log Catcher

(Engine Side)

- With the log catcher angled upward, align the four holes on the log catcher with the 4 threaded holes on the log splitter beam.
- Place a $\varnothing 10$ flat washers (A) and $\varnothing 10$ lock washers (B) onto the four M10 \times 20 bolts (C) and thread them through the holes on the log catcher and into the holes on the log splitter beam and tighten securely.

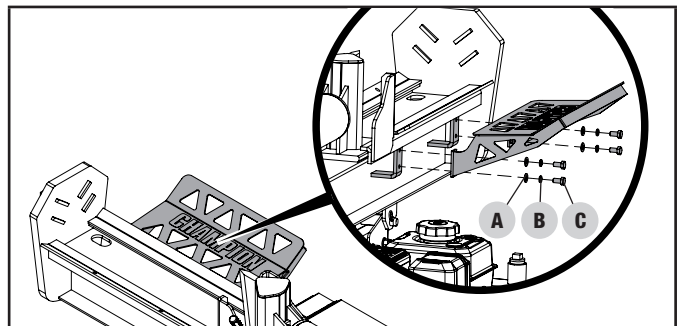

Add Engine Oil

⚠ WARNING

DO NOT attempt to crank or start the engine before it has been properly filled with the recommended type and amount of oil. Damage to the log splitter as a result of failing to follow these instructions will void your warranty.

🗨 NOTICE

The recommended oil type is **10W-30 automotive oil**.

Recommended Engine Oil Type								
	10W-30							
	5W-30				10W-40			
	5W-30 Full Synthetic							
°F	-20	0	20	40	60	80	100	120
°C	-28.9	-17.8	-6.7	4.4	15.6	26.7	37.8	48.9
Ambient temperature								

1. Place the log splitter on a flat, level surface.
2. Remove oil fill cap/dipstick to add oil.
3. Using a funnel, add up to 16.9 fl. oz (500 ml) (included) of oil and replace oil fill cap/dipstick. DO NOT OVERFILL.
4. Check engine oil level daily and add as needed.

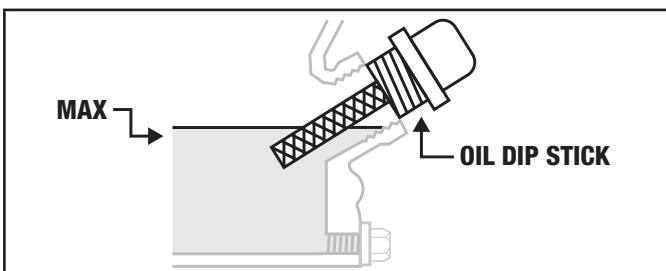

🗨 NOTICE

Once oil has been added, a visual check should show oil about 1-2 threads from running out of the fill hole.

If using the dipstick to check oil level, DO NOT screw in the dipstick while checking.

🗨 NOTICE

Check oil often during the break-in period. Refer to the *Maintenance* section for recommended service intervals.

⚠ CAUTION

The engine is equipped with a low oil shut-off and will stop when the oil level in the crankcase falls below the threshold level.

🗨 NOTICE

We consider the first 5 hours of run time to be the break-in period for the engine. During the break in period we recommend using standard automotive non-synthetic blended oils. After the break in period synthetic lubricant can be used but is not required. Avoid bogging or lugging the engine down and avoid prolonged running at constant RPM. After the 5 hour break-in period, change the oil.

🗨 NOTICE

Weather will affect engine oil and engine performance. Change the type of engine oil used based on weather conditions to suit the engine needs.

🗨 NOTICE

Synthetic oil may be used after the 5 hour initial break-in period. Using synthetic oil does not decrease the recommended oil change interval. Full synthetic 5W-30 oil will aid in starting in cold ambient < 41°F (5°C)

Add Fuel

⚠ DANGER

Gasoline vapors are highly flammable and extremely explosive.

DO NOT light or smoke cigarettes. Fire or explosion can cause severe burns or death.

Always fill or drain fuel outdoors in a well-ventilated area. DO NOT pump gasoline directly into the log splitter. Use an approved container to transfer the fuel to the log splitter.

Never use a gasoline container, gasoline tank, or any other fuel item that is broken, cut, torn or damaged.

DO NOT overfill the gasoline tank. Always keep fuel away from sparks, open flames, pilot lights, heat and other sources of ignition.

Use clean, fresh, regular unleaded gasoline with a minimum octane rating of 87 and an ethanol content of less than 10% by volume. E10 E15 E85

DO NOT mix oil with gasoline.

1. Remove the gasoline cap.

2. Slowly add gasoline to the tank. **DO NOT OVERFILL.** Gasoline can expand after filling. A minimum of $\frac{1}{4}$ in. (6.4 mm) of space left in the tank is required for gasoline expansion, although more than $\frac{1}{4}$ in. (6.4 mm) is recommended. Gasoline can be forced out of the tank as a result of expansion if overfilled, and can affect the stable running condition of the log splitter.

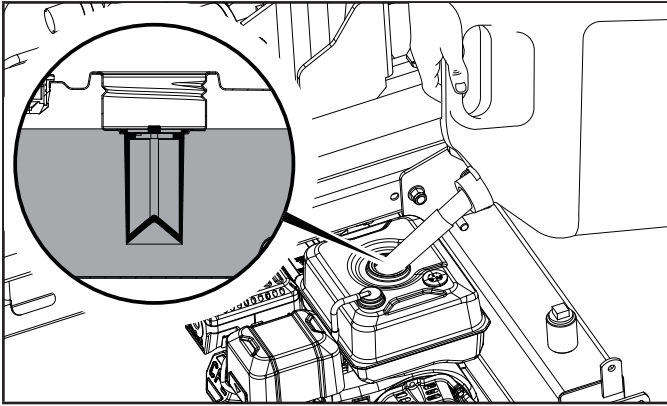

3. The approximate fuel level is shown on the fuel gauge on top of the fuel tank.

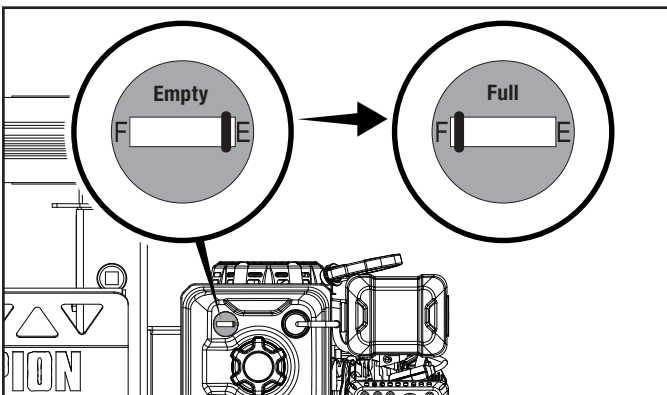

CAUTION

Use regular unleaded gasoline with a minimum octane rating of 87 and an ethanol content of less than 10% by volume.

DO NOT light cigarettes or smoke when filling the tank.

DO NOT mix oil and gasoline.

Fill tank to approximately $\frac{1}{4}$ in. (6.4 mm) below the top of the tank to allow for gasoline expansion.

DO NOT pump gasoline directly into the log splitter at the pump. Use an approved container to transfer the gasoline to the log splitter.

DO NOT fill tank indoors.

DO NOT fill tank when the engine is running or hot.

DO NOT overfill the tank.

WARNING

Pouring gasoline too fast through the fuel screen may result in blow back of gasoline at the operator while filling.

NOTICE

The engine works well with 10% or less ethanol blended gasoline. When using ethanol-gasoline blends there are some issues worth noting:

- Ethanol-gasoline blends can absorb more water than gasoline alone.
- These ethanol blends can eventually separate, leaving water or a watery goo in the tank, fuel valve and carburetor. The compromised gasoline can be drawn into the carburetor and cause damage to the engine and/or create potential hazards.
- If a fuel stabilizer is used, confirm that it is formulated to work with ethanol-gasoline blends.
- Any damages or hazards caused by using ethanol blended gasoline higher than 10% by volume, improperly stored gasoline, and/or improperly formulated stabilizers, are not covered by manufacturer's warranty.

It is advisable to always shut off the gasoline supply and run the engine to starvation after each use. See *Storage* instructions for extended non-use.

Add Hydraulic Oil

If your log splitter was delivered pre-assembled, follow these instructions:

1. Position the log splitter on a flat, level surface.
2. Remove the plastic shipping plug from the oil tank on the top of the tank (A) and discard. Replace with the steel oil plug (with breather hole) shipped with your log splitter (A).

CAUTION

Do not run the log splitter with temporary shipping plug.

Pressure will build up inside the tank and potential damage could occur.

NOTICE

Hydraulic tank is deliberately overfilled before shipping from the factory. When the unit has been operated, oil will adjust to proper level.

- After running and cycling the unit several minutes (purging air from the system), turn off the engine and check the hydraulic oil level using the oil sight glass. Oil level should visibly fill the glass sight.

If your log splitter was delivered unassembled, follow these instructions:

- Make sure the log splitter is on a flat, level surface.
- Remove the oil plug from the oil tank (A).
- Add 5 gal. (18.9 L) of hydraulic oil - see specification section for types of acceptable oil.
- Check the hydraulic oil level using the oil sight glass. Oil level should visibly fill the sight glass.

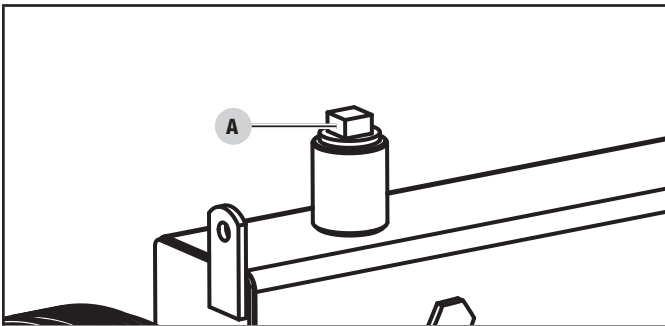

⚠ WARNING

DO NOT remove the hydraulic oil fill cap when the engine is running or hot. Hot oil can escape causing severe burns. Always allow the log splitter to cool completely before removing the hydraulic oil cap.

High fluid pressure and temperatures are created in the hydraulic log splitters. Hydraulic fluid will escape through a pin-size hole opening and can puncture skin and cause severe blood poisoning.

Inspect hydraulic system regularly for possible leaks. Never check for leaks with your hand while the system is pressurized. Seek medical attention immediately if injured by escaping fluid.

- Replace and tighten the oil plug and orient the vent hole away from the operator zone.
- Start Engine. (See starting the engine section)
- Extend and retract the wedge to purge air from the hydraulic system. When the wedge motion is smooth, the system is properly purged.
- Check the hydraulic oil tank sight glass. Add approximately 0.8 gal. (3 L) of hydraulic oil to bring the level back up to the sight glass. Do NOT overfill.
- Check oil level daily and add as needed.

🗨 NOTICE

When the outdoor temperature is below 32°F (0°C), Dexron III transmission fluid can be used. Do not mix hydraulic oil and transmission fluid. Drain all oil or fluid before adding the other one.

See hydraulic oil system specifications section for more details.

🗨 NOTICE

To check oil level, use the oil sight glass on the tank. The oil sight glass has a marker for the acceptable level of oil. If oil is below the marker, add oil as needed. DO NOT OVERFILL.

Before Each Use Inspect the Log Splitter

- Check the hydraulic oil level and visually inspect all hoses, attachments and cylinder for loose fittings, leaks, cracks, fraying or other damage.
- DO NOT operate the log splitter if there is any indication of damage.
- Inspect the engine and make sure the oil level is correct before operating. If the engine is equipped with a spark arrestor, clean and inspect it regularly (follow spark arrestor maintenance schedule).
- The tires need to be fully inflated and in good repair. Reference the tire sidewall for recommended tire pressure.

⚠ WARNING

DO NOT over inflate tires. Serious injury can result if tires explode.

DO NOT tow the log splitter if the tires are worn or will not hold air.

DO NOT exceed the maximum 45 MPH (72 KM/H) towing speed.

Changing Beam from Horizontal to Vertical Orientation

When logs are too heavy to lift, the log splitter beam can be moved from horizontal to vertical orientation.

To change from horizontal to vertical orientation:

1. Block the wheels to prevent the unit from rolling.
2. Pull the spring loaded pin out on the horizontal beam lock attached to the tow bar to release the beam. Standing alongside the hydraulic ram, (opposite side from the engine) firmly grasp the handle on the beam and lift upward while pushing the beam back until upright. (Caution, beam is heavy.)

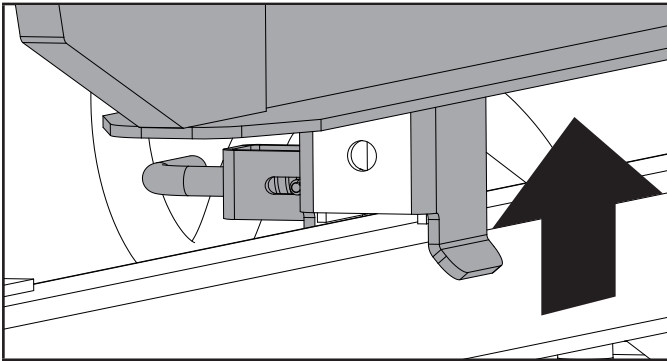
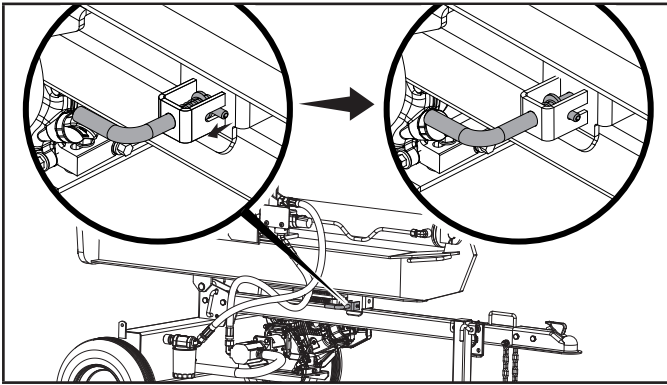

3. Pull out the spring loaded quick-lock pin and rotate it around to the 9 o'clock position around the lip on the beam to secure it in the vertical position.

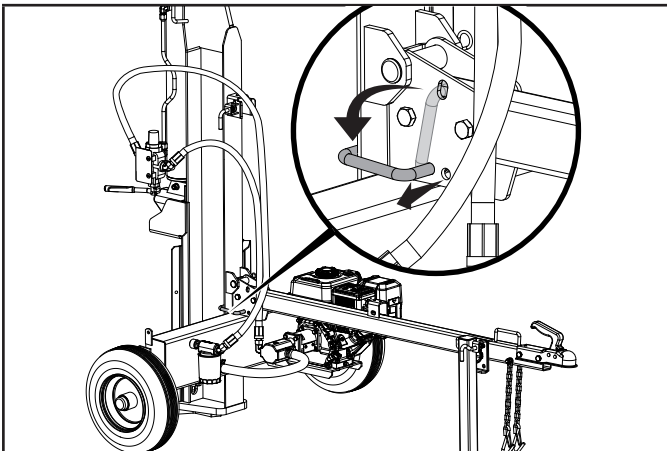

4. To change from vertical to horizontal orientation, reverse the steps. The beam will automatically lock into the auto-lock on the tow bar when lowered into position.

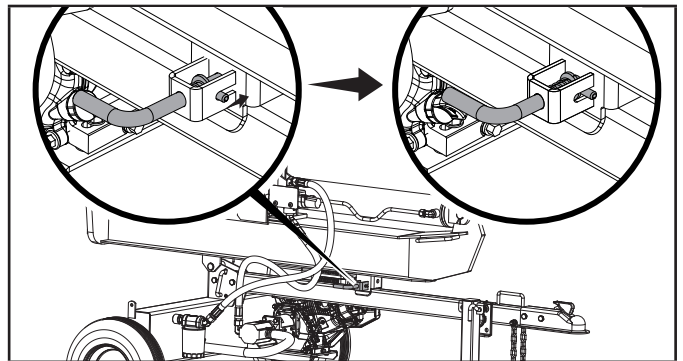
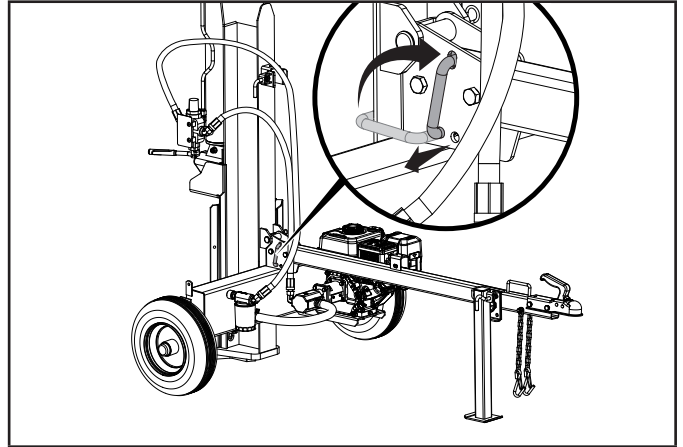

Towing Log Splitter Safety

⚠ WARNING

1. Always check local, state or provincial regulations regarding towing, licensing and lights before towing your log splitter. Review towing safety warnings in your towing vehicle manual.
2. Before towing make sure the log splitter is correctly and securely attached to the vehicle and the safety chains attached with enough slack to allow for turning.
3. Before transporting the log splitter, always check that the fuel valve is OFF and the fuel tank is empty.
4. Support leg must be pinned in the "UP" position for towing.
5. If using a log splitter cover, ALWAYS remove the cover before towing the log splitter.
6. Never exceed the max. travel speed of 45 mph (72 km/h). Towing the log splitter at speeds greater than 45 mph (72 km/h) could result in serious injury or death. Always adjust your towing speed according to the terrain and conditions.
7. Always disconnect the log splitter from the towing vehicle before operating.

Log Splitter Location

⚠ WARNING

ALWAYS operate the log splitter outdoors.

NEVER place or operate the log splitter near windows, doors, vents, air intakes or other openings where poisonous engine exhaust fumes could be drawn into occupied building spaces.

Always maintain a minimum distance of 5 ft. (1.5 m) from dry combustible vegetation to prevent fires when operating this log splitter.

Always leave a minimum of 3 ft. (0.9 m) of clearance on all sides of the log splitter to allow for safe operation, adequate cooling, maintenance and servicing.

Always place the log splitter on a firm level surface to provide for good operational footing.

DO NOT work on mud, ice, or in tall grass, brush or snow.

ALWAYS operate log splitter around work zone as shown below.

HORIZONTAL OPERATING POSITION

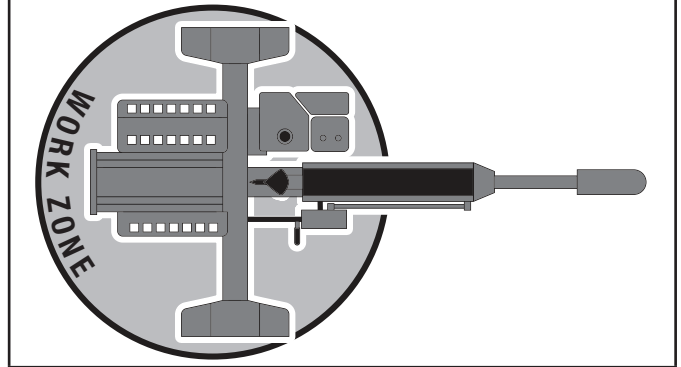

VERTICAL OPERATING POSITION

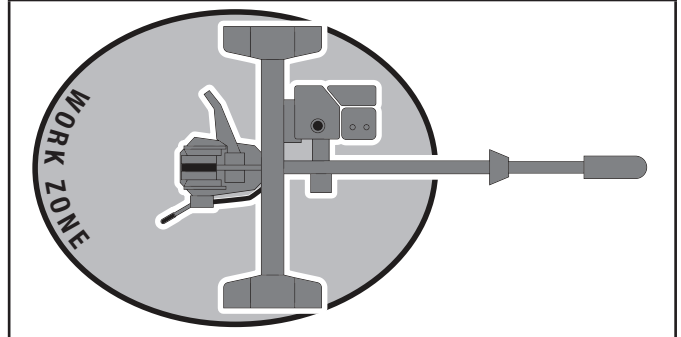

🗨 NOTICE

For Vertical Operation:

- Remove the beam lock-pin from the beam bracket
- Use handle on cylinder to rotate beam to vertical position.
- Insert beam lock-pin in the pivot bracket.

⚠ WARNING

ALWAYS use the log splitter for its intended use. The log splitter must always be used to split wood logs, length wise with the grain.

NEVER modify, change engine settings, operating speeds, pressure settings or make other changes to the log splitter. Any modifications could lead to property damage, cause serious personal injury or death and will void the manufacturers warranty.

NEVER attach a rope, cable or other device to the control lever on the log splitter.

ALWAYS operate the log splitter in daylight.

NEVER operate, or let anyone else operate the log splitter while under the influence of alcohol, drugs, or medication.

NEVER leave the log splitter unattended while the engine is running.

DO NOT change the splitting position with the engine running. Contact with a hot muffler can cause serious burns.

ALWAYS make sure the beam is in the locked position.

DO NOT let the beam drop as it could cause serious personal injury, crush fingers, hands or damage the log splitter.

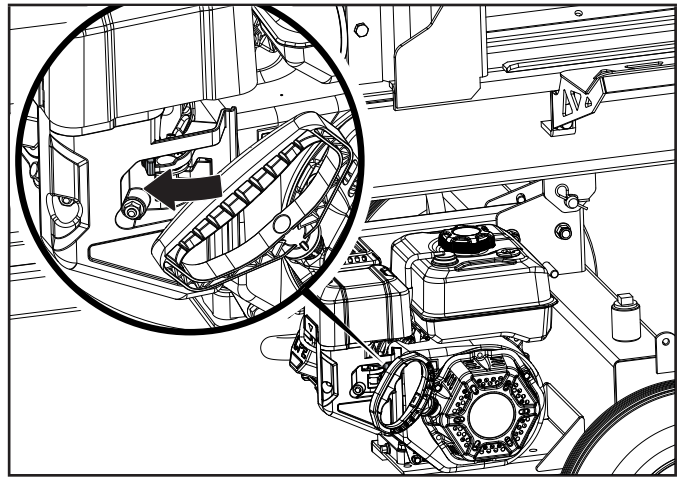

4. Pull the starter cord until resistance is felt and then pull rapidly.

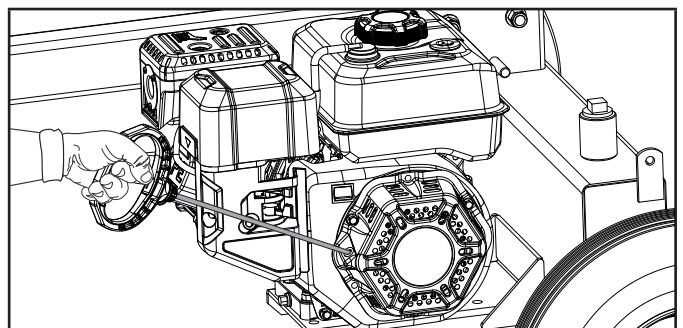

5. As engine warms up, move the choke lever to the "RUN" position.

OPERATION**⚠ DANGER**

Always operate log splitter outdoors and far away from building, windows, doors and intake ventilation covers.

Starting the Engine

1. Make certain the log splitter is on a flat, level surface.
2. Move the fuel valve to the "ON" position.

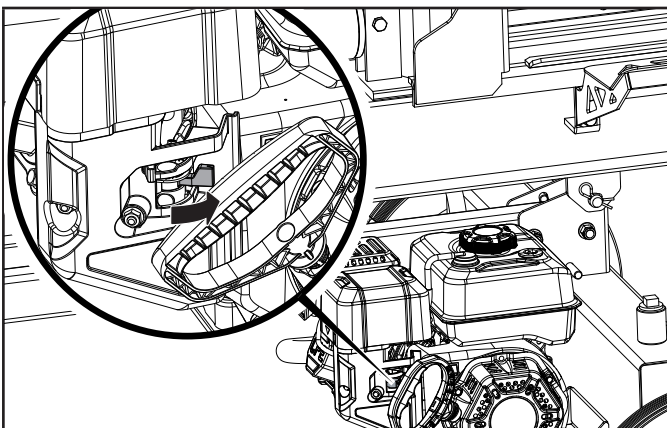

3. Move the choke lever to the "CHOKE" position.

🗨 NOTICE

Keep choke lever in "CHOKE" position for 2 pulls of the recoil starter. After second pull, move choke lever to the "RUN" position for up to the next 3 pulls of the recoil starter.

Too much choke leads to spark plug fouling/engine flooding due to the lack of incoming air. This will cause the engine not to start.

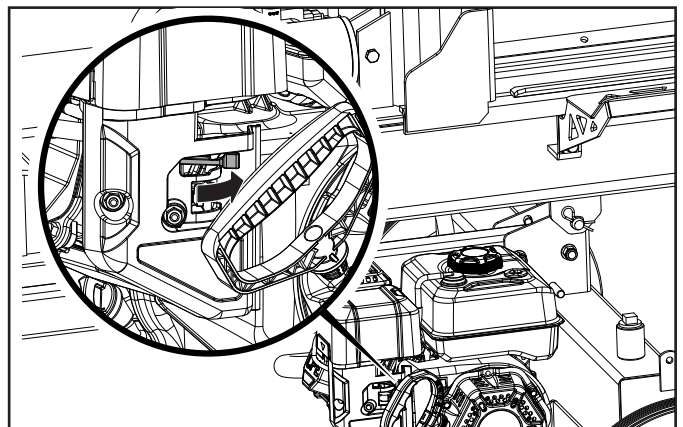

NOTICE

If the engine starts but does not run make certain that the log splitter is on a flat, level surface. The engine is equipped with a low oil sensor that will prevent the engine from running when the oil level falls below a critical threshold.

Stopping the Engine

In an emergency, turn the engine switch to the “OFF” position.

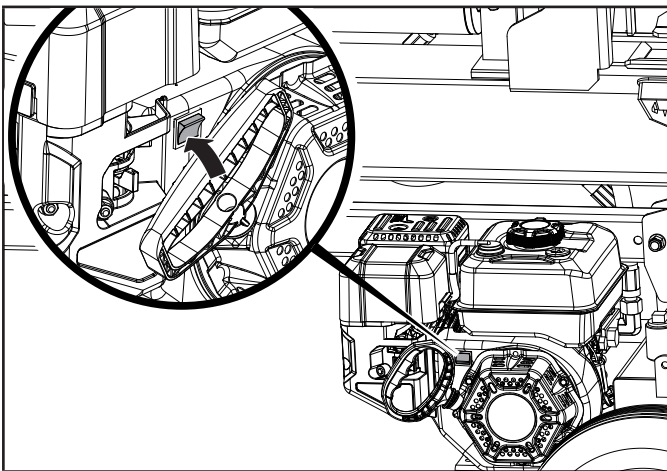
**Under normal operation:**

1. Turn the fuel valve to the “OFF” position.

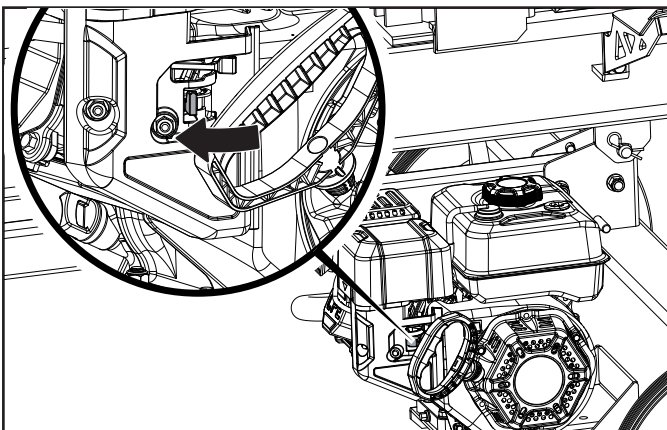

2. Let the engine run until fuel starvation has stopped the engine. This usually takes few minutes.

Important: Always ensure that the fuel valve is in the “OFF” position when the engine is not in use.

NOTICE

If the engine will not be used for a period of two (2) weeks or longer, please see the *Storage* section for proper engine and fuel storage.

Log Splitter Operation

1. ALWAYS wear ear and eye protection, protective clothing and safety gear.

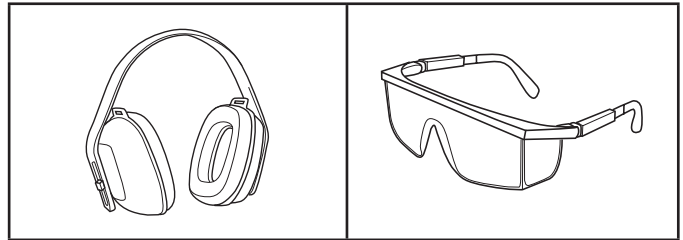

2. Block tires and ensure support leg is secure to prevent unintended movement of the log splitter during operation.
3. Set log splitter in either the horizontal or vertical position.

NOTICE

HORIZONTAL position is used for lighter logs that can easily be loaded onto the beam.

VERTICAL position is used for light logs as well as heavy logs that are difficult to load onto the beam.

Back injury can result from lifting logs onto the log splitter if proper lifting techniques are not used.

4. Load a log onto the beam against the end plate (MAX LOG LENGTH – 24 in. [61 cm]).
5. To stabilize the log, place your left hand on the side of the log.

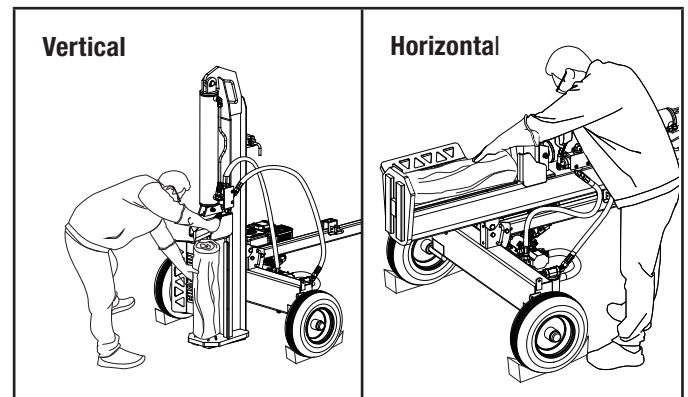
**WARNING**

Never place your hand on the ends of the log, between the log and end plate or the log and the splitting wedge.

WARNING

Only one operator permitted. The adult who loads and stabilizes the log, must be the person who operates the control handle.

6. Make sure all limbs are clear of crush zones.
7. Use your right hand to push the control valve handle forward (towards the end plate) to split the log.
8. Remove left hand from the log once the wedge begins to contact with the log. Continue holding the control handle in the forward position until the log splits.
9. Push the auto control valve handle backward to return the wedge to its original position.
10. Clear the split wood from the work zone.

NOTICE

It is normal for the hydraulic fluid to appear foamy/frothy during operation. This can be caused by agitated oil in the tank collecting air.

NOTICE

If a log gets stuck, embedded or will not split completely, push the control handle in the reverse direction and allow the log splitter to strip the log from the wedge.

ALWAYS keep hands clear of the log and wedge while it is retracting.

NOTICE

The cylinder stroke is designed so the wedge stops approximately 1.5 in. (3.8 cm) from the end plate.

Operation at High Altitude

The density of air at high altitude is lower than at sea level. Engine power is reduced as the air mass and air-fuel ratio decrease. Engine power and log splitter output will be reduced approximately 3½% for every 1000 ft. of elevation above sea level. This is a natural trend and cannot be changed by adjusting the engine. At high altitudes increased exhaust emissions can also result due to the increased enrichment of the air fuel ratio. Other high altitude issues can include hard starting, increased fuel consumption and spark plug fouling.

To alleviate high altitude issues other than the natural power loss, CPE can provide a high altitude carburetor main jet. The alternative main jet and installation instructions can be obtained by contacting our Technical Support Team. Installation instructions are also available in the Technical Bulletin area of the CPE website.

The part number and recommended minimum altitude for the application of the high altitude carburetor main jet is listed in the table below.

In order to select the correct high altitude main jet it is necessary to identify the carburetor model. For this purpose, a code is stamped on the side of the carburetor. Select the correct high altitude jet part number corresponding to the carburetor code found on your particular carburetor.

Carb. Code	High Alt. Jet Part Number	Min. Altitude
16100-000057	16161-000027	3000-6000 ft. (914.4-1828.8 m)
	16161-000025	6000-8000 ft. (1828.8-2438.4 m)

WARNING

Operation using the alternative main jet at elevations lower than the recommended minimum altitude can damage the engine. For operation at lower elevations, the originally supplied standard main jet must be used. Operating the engine with the wrong engine configuration at a given altitude may increase its emissions and decrease fuel efficiency and performance.

MAINTENANCE

Make certain that the log splitter is kept clean and stored properly. Always operate the unit on a flat, level surface in a clean, dry operating environment. DO NOT expose the unit to extreme conditions, excessive dust, dirt, moisture or corrosive vapors. Inspect all air vents and cooling slots to ensure that they are clean and unobstructed.

Clean spark arrester every 100 hours.

Check and tighten all bolts and nuts before operating the log splitter.

WARNING

Never operate a damaged or defective log splitter.

WARNING

Improper maintenance will void your warranty.

NOTICE

For Emission control devices and systems, read and understand your responsibilities for service as stated in the Emission Control Warranty Statement of this manual.

The owner/operator is responsible for all periodic maintenance.

Refer to the *Maintenance Schedule* section of this manual to complete all scheduled maintenance in a timely manner.

Correct any issue before operating the log splitter.

For service or parts assistance, contact our Technical Support Team at 1-877-338-0999.

Cleaning the Log splitter

⚠ CAUTION

DO NOT spray engine with water.

Water can contaminate the fuel system and can enter the engine through the cooling slots and damage the engine.

Clear the debris from the beam, wedge and endplate.

Use a damp cloth to clean exterior surfaces of the engine and log splitter.

Use a soft bristle brush to remove excess dirt and oil.
Use an air compressor (25 PSI) to clear dirt and small debris.

Wipe all metal parts with an oily rag to help prevent rust and corrosion.

Changing the Engine Oil

Change oil when the engine is warm. Refer to the oil specification to select the proper grade for your operating environment.

1. Remove the oil drain plug with a 10 mm socket (not included) and extension.

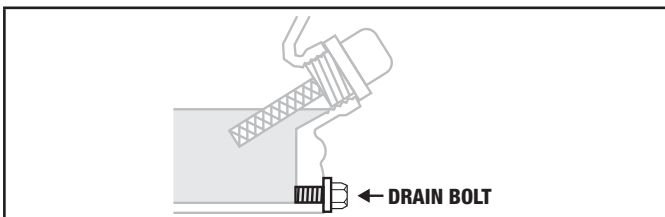

2. Allow the oil to drain completely into an appropriate container.
3. Replace the oil drain plug.
4. Remove the oil fill cap/dipstick to add oil.
5. Add oil according to *Add Engine Oil* in *Assembly* section. DO NOT OVERFILL. Oil not included for routine maintenance.
6. Dispose of used oil at an approved waste management facility.

🗨 NOTICE

Once oil has been added, a visual check should show oil about 1-2 threads from running out of the fill hole. If using the dipstick to check oil level, DO NOT screw in the dipstick while checking.

Cleaning and Adjusting the Spark Plug(s)

1. Remove the spark plug cable from the spark plug.
2. Use a spark plug socket tool (not included), or a 13/16 in. (21 mm) socket (not included) to remove the plug.
3. Inspect the electrode on the plug. It must be clean and not worn to produce the spark required for ignition.
4. Make certain the spark plug gap is 0.028-0.031 in. (0.7-0.8 mm).

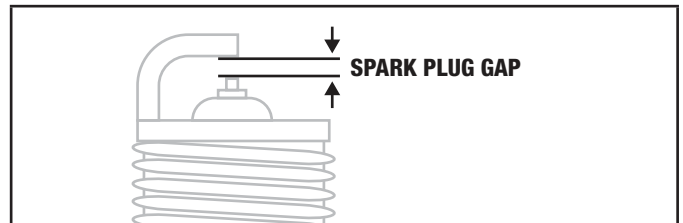

5. Refer to the spark plug types in *Specifications* when replacing the plug.
6. Firmly re-install the plug.
7. Attach the spark plug cable to the spark plug.

Cleaning the Air Filter

1. Using your finger, pry the outer tab up slightly and lift the air filter cover above the tab lock position.

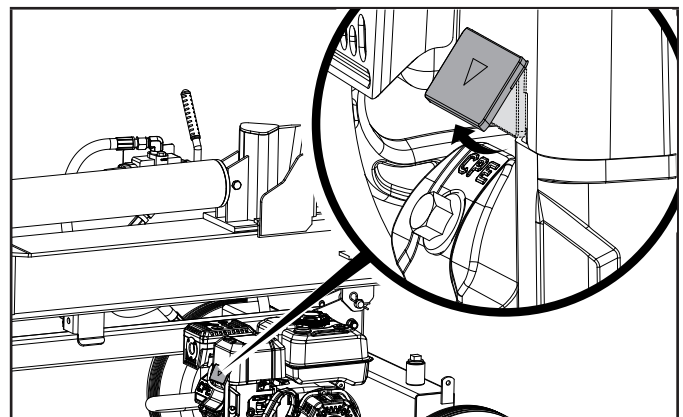

2. Remove both air filter cover and air filter element.

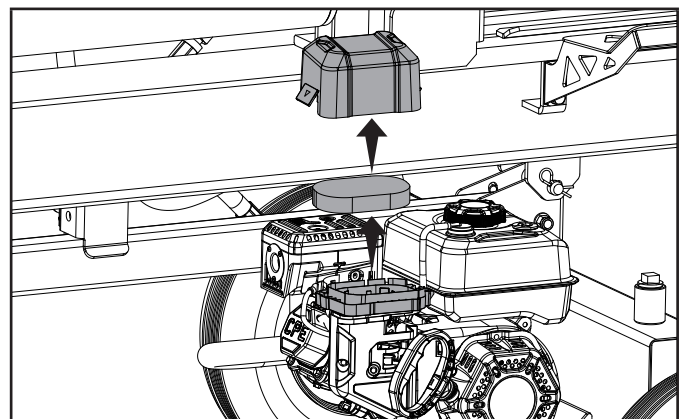

3. Wash in liquid detergent and water. Squeeze thoroughly dry in a clean cloth.
4. Saturate in clean engine oil.
5. Squeeze in a clean, absorbent cloth to remove all excess oil.
6. Place the filter in the assembly.
7. Reattach the air filter cover. Attach the side closest to the gas tank then pivot down to close. Make sure air filter cover snaps in place.

Changing the Hydraulic Oil

Always shut off the engine, disconnect the spark plug.

Change the hydraulic oil filter after the first 50 hours of use, then every 100 hours or seasonally.

NOTICE

When log splitters are not used for extended periods of time and they are exposed to changing temperature conditions, moisture through condensation can build up inside the tank.

1. Begin with the cylinder retracted and the engine fuel valve in the "OFF" position.
2. Release any stored pressure by moving the valve lever forward and backward several times.
3. Place a container under the hydraulic tank. Make sure it is large enough to hold the contents of the tank. See model specification section of this manual for hydraulic oil capacities.

NOTICE

The drain plug is sealed with Teflon® tape. Add 2-3 wraps of new Teflon® tape as needed when replacing the drain plug to prevent oil leak.

4. To drain the oil,
 - Place an oil drain container under the drain plug. Unscrew (counter-clockwise) and remove the tank drain plug on the bottom of the hydraulic tank. Allow oil to completely drain from the tank into the container. Re-apply Teflon® sealing tape to the drain plug threads, then reinsert and turn (clockwise) in the tank drain plug. Tighten, but do not over tighten.
 - Place an oil drain container under the external oil filter. Unscrew (counter-clockwise) and remove the external hydraulic oil filter and drain any oil in the filter into the container. A strap or oil filter wrench may be needed.

NOTICE

Oil will drain from the filter and filter housing.

- Locate an approved replacement filter.
- Lubricate the gasket of the new filter with a thin film of clean oil.
- Install a new hydraulic oil filter (A). Screw the new filter on clockwise. Tighten 3/4 - 1 turn after the gasket makes contact.

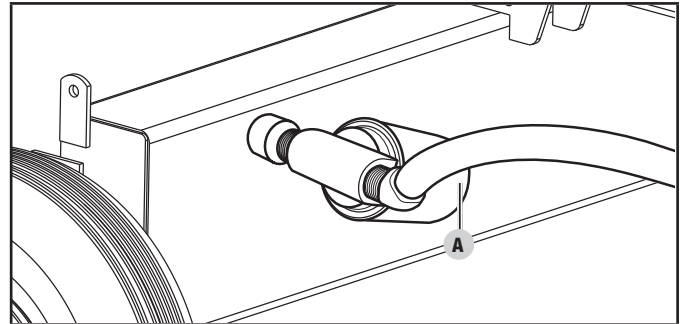

NOTICE

Install a new hydraulic oil filter each time the hydraulic oil is changed (if your log splitter includes this feature).

- Place an oil drain container under the large clear hose that runs from the tank to the pump.
 - Loosen the hose clamp attached to the fitting on the tank.
 - Disconnect hose from fitting and drain oil into the container.
 - Using a large wrench, unscrew the fitting from the tank to expose the internal tank filter.
 - Check for any debris on the screen. Using a clean towel or air gun, carefully remove any debris.

NOTICE

Be careful when handling the screen as it can be easily damaged.

- Apply new Teflon® sealing tape to threads, reinsert into tank and tighten. Be careful to tighten, but do not over tighten.
5. Unscrew and remove the tank fill plug on top of the tank (B). Using a funnel, add approximately 5 gal. (18.9 L) of hydraulic oil to the tank. Wipe up any spilled oil.
 6. Turn the fuel valve to the "ON" position, and start the engine. Purge the air from the system by extending and retracting the wedge several times until the motion is smooth.
 7. Check the hydraulic oil level using the sight glass. Add 0.8 gal. (3 L) of hydraulic oil, so the oil level is visible in the sight glass (C).

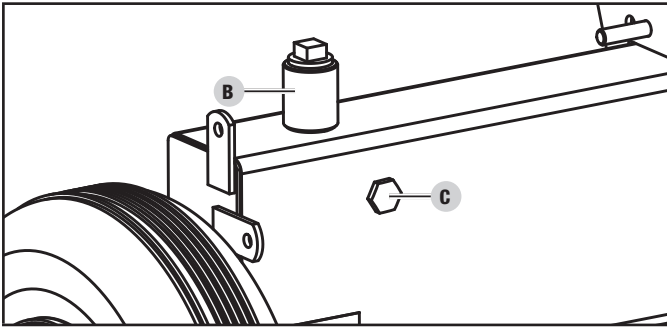

8. Dispose of used oil at approved recycling locations in accordance with Federal, State, Local or Provincial regulations.

⚠ WARNING

Always shut off the engine, disconnect the spark plug, and relieve system pressure before cleaning, adjusting, or repairing the log splitter. Relieve system pressure by moving split control lever back and forth several times

🗨 NOTICE

Refer to *Specifications* for a list of compatible replacement filters or call Champion Power Equipment at 1-877-338-0999 to order a replacement OEM filter.

Maintenance Schedule

Follow the service intervals indicated in the following maintenance schedule.

Service your log splitter more frequently when operating in adverse conditions.

Contact our Technical Support Team at 1-877-338-0999 to locate the nearest CPE certified service dealer for your log splitter or engine maintenance needs.

EVERY 8 HOURS OR DAILY

- Check engine and hydraulic oil levels
- Clean around air intake and muffler

FIRST 5 HOURS

- Change oil

EVERY 50 HOURS OR EVERY SEASON

- Clean air filter
- Change oil if operating under heavy load or in hot environments

EVERY 100 HOURS OR EVERY SEASON

- Change oil
- Clean/adjust spark plug
- Check/adjust valve clearance*
- Clean spark arrestor
- Clean fuel tank and filter*
- Change hydraulic oil
- Change hydraulic oil filter

EVERY 250 HOURS

- Clean combustion chamber*

EVERY YEAR

- Inspect wheel bearings and repack bearing grease as needed.

EVERY 3 YEARS

- Replace fuel line*

**To be performed by knowledgeable, experienced owners or CPE certified service centers.*

STORAGE

Refer to the *Maintenance* section for proper cleaning instructions.

Log Splitter Storage

1. The log splitter needs to be cool for at least 5 minutes before storing.
2. Clean the log splitter before storage according to the *Maintenance* section.
3. Retract the wedge to protect the rod from corrosion.
4. Wipe the beam and wedge with an oily rag to prevent rust and corrosion.

Engine Stored for Less than 30 Days

1. Allow the engine to cool completely before storage.
2. Clean engine according to the *Maintenance* section.
3. To extend the fuel storage life add a properly formulated fuel stabilizer to the tank.
4. Ensure the fuel valve is in the “OFF” position.

Engines Stored for Over 30 Days

1. Add a properly formulated fuel stabilizer to the tank.
2. Run the engine for a few minutes so the treated fuel cycles through the fuel system and carburetor.
3. Turn the fuel valve to the “OFF” position.
4. Let the engine run until fuel starvation has stopped the engine. This usually takes a few minutes.
5. The engine needs to cool completely before cleaning and storage.
6. Clean the engine according to the *Maintenance* section.
7. Change the oil.
8. Remove the spark plug and pour about 14.8 mL (½ ounce) of oil into the cylinder. Using the Recoil, crank the engine slowly to distribute the oil and lubricate the cylinder.
9. Reattach the spark plug.

WARNING

Never store the log splitter indoors next to appliances where there is a source of heat or open flame, spark or pilot light because they can ignite gasoline vapors.

DO NOT store a log splitter near fertilizer or any corrosive material. Even with an empty gas tank, gasoline vapors could ignite.

SPECIFICATIONS

Log Splitter Specifications

Ram Force	27 Ton
Cycle Time	16 seconds
Hydraulic Tank Capacity	5 gal. (18.9 L)
Max Log Length	24 in. (61 cm)
Max Log Weight	100 lb. (45 kg)
Coupler Ball Size	2 in. (5.1 cm)
Tire Size	16 in. (40.6 cm)
Max towing speed	45 MPH (72 KM/H)
Cylinder size	4.8 in. × 23 in. (12 cm × 58.4 cm)
Cylinder rod size	1.8 in. (4.5 cm)
Gear Pump	2-stage
Max pressure	3600 psi
Max flow capacity	14 GPM (53 LPM)
Control Valve	Detent (auto-return)
Net Weight	465 lb. (211 kg)
Length	87.3 in. (221.8 cm)
Width	51.3 in. (130.2 cm)
Height	40.8 in. (103.6 cm)

Engine Specifications

Model	R224P
Displacement	224 cc
Type	4-Stroke OHV
Start Type	Manual

Oil Specifications

DO NOT OVERFILL.

Type	See chart below
Capacity	16.9 fl. oz (500 ml)

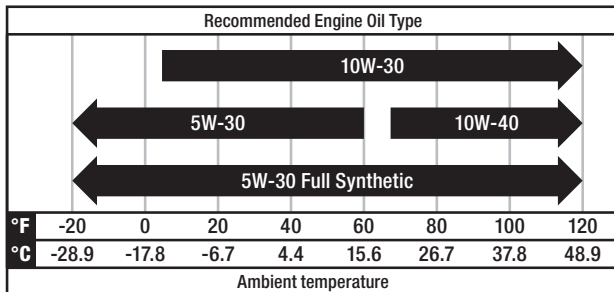

NOTICE

Temperature will affect engine oil and engine performance. Change the type of engine oil used based on temperature shown in the "Recommended Engine Oil Type" table.

Hydraulic Oil System

Capacity 5.8 gal. (22 L)

For year round use in warmer climates (always ABOVE 32°F/ 0°C):

- ISO 32/SAE10W
- Universal Hydraulic Oil

For year round use in colder climates (BELOW 32°F/ 0°C):

- Automatic Transmission Fluid

Replacement filters:

- Fram PH9342
- K&N HP-2008
- Wix 51361

Fuel Specifications

Use regular unleaded gasoline with a minimum octane rating of 87 and an ethanol content of less than 10% by volume. DO NOT USE E15 or E85. DO NOT OVERFILL.

Gasoline Capacity 0.82 gal. (3.1 L)

Spark Plug Specifications

OEM Type	F6RTC
Replacement Type	NGK BPR6ES or equivalent
Gap	0.028-0.031 in. (0.7-0.8 mm)

Valve Specifications

Intake Clearance	0.004-0.006 in. (0.10-0.15 mm)
Exhaust Clearance	0.0059-0.0079 in. (0.15-0.2 mm)

NOTICE

A technical bulletin regarding valve adjustment procedures is available at www.championpowerequipment.com.

Important Message About Temperature

Your product is designed and rated for continuous operation at ambient temperatures up to 104°F (40°C). When your product is needed it may be operated at temperatures ranging from 5°F (-15°C) to 122°F (50°C) for short periods of time. If exposed to temperatures outside this range during storage, it should be brought back within this range before operation. In any event, the product must always be operated outdoors, in a well-ventilated area and away from doors, windows and vents.

NOTICE

When temperature is below 32°F (0°C) use Automatic Transmission Fluid (Dexron-III or similar).

TROUBLESHOOTING

Problem	Cause	Solution
Engine will not start.	No fuel.	Add fuel.
	Faulty spark plug.	Replace spark plug.
	Unit loaded during start up.	Remove load from unit.
Engine will not start; Engine starts but runs roughly.	Low oil level.	Fill crankcase to the proper level. Place log splitter on a flat, level surface.
	Choke in the wrong position.	Adjust choke.
	Spark plug wire loose.	Attach wire to spark plug.
Engine shuts down during operation.	Out of fuel.	Fill fuel tank.
	Low oil level.	Fill crankcase to the proper level. Place log splitter on a flat, level surface.
Engine cannot supply enough power or overheating.	Insufficient ventilation.	Check for air restriction. Move to a well ventilated area.
Wedge movement is slow or erratic.	Air in the hydraulic oil system.	Purge air by extending and retracting the wedge several times until motion is smooth.
	Debris lodged in beam guides.	Clear debris from beam.
	Low hydraulic oil.	Check oil level and add as needed.
Oil leak from cylinder.	Faulty cylinder rod seal.	Contact Customer Service.
	Scored or bent cylinder rod.	Contact Customer Service.
	Loose hydraulic fitting.	Tighten hydraulic fitting.
	Faulty combination washer seal on cylinder hydraulic fitting.	Contact Customer Service.
Wedge will not extend or retract.	Faulty control valve.	Contact Customer Service.
	Faulty hydraulic pump.	Contact Customer Service.
	Low hydraulic oil.	Check oil level and add as needed.
Excessive bouncing while towing.	Under-inflated tires.	Inflate tires to proper pressure. Refer to tire sidewall.

For further technical support:

Technical Support Team
Toll Free 1-877-338-0999
support@championpowerequipment.com

WARRANTY*

CHAMPION POWER EQUIPMENT
2 YEAR LIMITED WARRANTY

Warranty Qualifications

To register your product for warranty and FREE lifetime call center technical support please visit:

<https://www.championpowerequipment.com/register>

To complete registration you will need to include a copy of the purchase receipt as proof of original purchase. Proof of purchase is required for warranty service. Please register within ten (10) days from date of purchase.

Repair/Replacement Warranty

CPE warrants to the original purchaser that the mechanical and electrical components will be free of defects in material and workmanship for a period of two years (parts and labor) from the original date of purchase and 180 days (parts and labor) for commercial and industrial use. Transportation charges on product submitted for repair or replacement under this warranty are the sole responsibility of the purchaser. This warranty only applies to the original purchaser and is not transferable.

Do Not Return The Unit To The Place Of Purchase

Contact CPE's Technical Service and CPE will troubleshoot any issue via phone or e-mail. If the problem is not corrected by this method, CPE will, at its option, authorize evaluation, repair or replacement of the defective part or component at a CPE Service Center. CPE will provide you with a case number for warranty service. Please keep it for future reference. Repairs or replacements without prior authorization, or at an unauthorized repair facility, will not be covered by this warranty.

Warranty Exclusions

This warranty does not cover the following repairs and equipment:

Normal Wear

Products with mechanical and electrical components need periodic parts and service to perform well. This warranty does not cover repair when normal use has exhausted the life of a part or the equipment.

Installation, Use and Maintenance

This warranty will not apply to parts and/or labor if the product is deemed to have been misused, neglected, involved in an accident, abused, loaded beyond the product's limits, modified, installed improperly or connected incorrectly to any electrical component. Normal maintenance is not covered by this warranty and is not required to be performed at a facility or by a person authorized by CPE.

Other Exclusions

This warranty excludes:

- Cosmetic defects such as paint, decals, etc.
- Wear items such as filter elements, o-rings, etc.
- Accessory parts such as hoses, storage covers, etc.
- Failures due to acts of God and other force majeure events beyond the manufacturer's control.
- Problems caused by parts that are not original Champion Power Equipment parts.

Limits of Implied Warranty and Consequential Damage

Champion Power Equipment disclaims any obligation to cover any loss of time, use of this product, freight, or any incidental or consequential claim by anyone from using this product. THIS WARRANTY AND THE ATTACHED U.S. EPA and/or CARB EMISSION CONTROL SYSTEM WARRANTIES (WHEN APPLICABLE) ARE IN LIEU OF ALL OTHER WARRANTIES, EXPRESS OR IMPLIED, INCLUDING WARRANTIES OF MERCHANTABILITY OR FITNESS FOR A PARTICULAR PURPOSE.

This warranty gives you certain legal rights which may change from state to state or province to province. Your state or province may also have other rights you may be entitled to that are not listed within this warranty.

Contact Information

Address

Champion Power Equipment, Inc.
6370 S Pioneer Way, Unit 101
Las Vegas, NV 89113 USA
www.championpowerequipment.com

Customer Service

Toll Free: 1-877-338-0999
info@championpowerequipment.com
Fax no.: 1-562-236-9429

Technical Service

Toll Free: 1-877-338-0999
tech@championpowerequipment.com
📞 EMERGENCY 24 HOUR SUPPORT: 1-562-204-1188

*Except as otherwise stipulated in any of the following enclosed Emission Control System Warranties (when applicable) for the Emission Control System: U.S. Environment Protection Agency (EPA) and/or California Air Resources Board (CARB).

**CHAMPION POWER EQUIPMENT, INC. (CPE)
AND THE UNITED STATES ENVIRONMENTAL PROTECTION AGENCY (U.S. EPA)
EMISSION CONTROL SYSTEM WARRANTY**

Your Champion Power Equipment (CPE) engine complies with U.S. EPA emissions regulations.

YOUR WARRANTY RIGHTS AND OBLIGATIONS:

The US EPA and CPE are pleased to explain the Federal Emission Control Systems Warranty on your 2023 small off-road engine (SORE) and engine powered equipment. New engines and equipment must be designed, built and equipped, at the time of sale, to meet U.S. EPA regulations for small off-road engines (SORE). CPE warrants the emission control system on your small off-road engine (SORE) and equipment for the period of time listed below, provided there has been no abuse, neglect, unapproved modification, or improper maintenance of your equipment.

Your emission control system may include parts such as the carburetor, fuel-injection system, the ignition system, catalytic converter and fuel lines. Also included may be hoses, belts, connectors and other emission related assemblies. Where a warrantable condition exists, CPE will repair your small off-road engine (SORE) at no cost to you including diagnosis, parts and labor.

MANUFACTURER'S EMISSION CONTROL SYSTEM WARRANTY COVERAGE:

This emission control system is warranted for two years, subject to provisions set forth below. If, during the warranty period, an emission related part on your engine is defective in materials or workmanship, the part will be repaired or replaced by CPE.

OWNER WARRANTY RESPONSIBILITIES:

As the small off-road engine (SORE) owner, you are responsible for the performance of the required maintenance listed in your Owner's Manual. CPE recommends that you retain all your receipts covering maintenance on your small off-road engine, but CPE cannot deny warranty solely for the lack of receipts or for your failure to ensure the performance of all scheduled maintenance.

As the small off-road engine (SORE) owner, you should however be aware that CPE may deny you warranty coverage if your small, off-road engine (SORE) or a part has failed due to abuse, neglect, improper maintenance or unapproved modifications.

You are responsible for presenting your small off-road engine (SORE) to an Authorized CPE service outlet or alternate service outlet as described in (3)(f.) below, CPE dealer or CPE, Las Vegas, NV. as soon as a problem exists. The warranty repairs should be completed in a reasonable amount of time, not to exceed 30 days.

If you have any questions regarding your warranty rights and responsibilities, you should contact:

Champion Power Equipment, Inc.
Customer Service
6370 S Pioneer Way, Unit 101
Las Vegas, NV 89113
1-877-338-0999
tech@championpowerequipment.com

EMISSION CONTROL SYSTEM WARRANTY

The following are specific provisions relative to your Emission Control System (ECS) Warranty Coverage.

- 1. APPLICABILITY:** This warranty shall apply to 1997 and later model year small off-road engines (SORE). The ECS Warranty Period shall begin on the date the new engine or equipment is delivered to its original, end-use purchaser, and shall continue for 24 consecutive months thereafter.
- 2. GENERAL EMISSIONS WARRANTY COVERAGE**

CPE warrants to the original, end-use purchaser of the new engine or equipment and to each subsequent purchaser that each of its small off-road engines (SORE) is:

 - 2a. Designed, built and equipped so as to conform to U.S. EPA emissions standards for spark-ignited engines at or below 19 kilowatts.
 - 2b. Free from defects in materials and workmanship that cause the failure of a warranted part to be identical in all material respects to the part as described in the engine manufacturer's application for certification for a period of two years.
- 3. THE WARRANTY ON EMISSION-RELATED PARTS WILL BE INTERPRETED AS FOLLOWS:**
 - 3a. Any warranted part that is not scheduled for replacement as required maintenance in the Owners Manual shall be warranted for the ECS Warranty Period. If any such part fails during the ECS Warranty Period, it shall be repaired or replaced by CPE according to Subsection "d" below. Any such part repaired or replaced under the ECS Warranty shall be warranted for any remainder of the ECS Warranty Period.
 - 3b. Any warranted, emissions-related part which is scheduled only for regular inspection as specified in the Owners Manual shall be warranted for the ECS Warranty Period. A statement in such written instructions to the effect of "repair or replace as necessary", shall not reduce the ECS Warranty Period. Any such part repaired or replaced under the ECS Warranty shall be warranted for the remainder of the ECS Warranty Period.
 - 3c. Any warranted, emissions-related part which is scheduled for replacement as required maintenance in the Owner's Manual shall be warranted for the period of time prior to the first scheduled replacement point for that part. If the part fails prior to the first scheduled replacement, the part shall be repaired or replaced by CPE according to Subsection "d" below. Any such emissions-related part repaired or replaced under the ECS Warranty, shall be warranted for the remainder of the ECS Warranty Period prior to the first scheduled replacement point for such emissions-related part.
 - 3d. Repair or replacement of any warranted, emissions-related part under this ECS Warranty shall be performed at no charge to the owner at a CPE Authorized Service Outlet.
 - 3e. The owner shall not be charged for diagnostic labor which leads to the determination that a part covered by the ECS Warranty is in fact defective, provided that such diagnostic work is performed at a CPE Authorized Service Outlet.
 - 3f. CPE shall pay for covered emissions warranty repairs at non-authorized service outlets under the following circumstances:
 - i. The service is required in a population center with a population over 100,000 according to U.S. Census 2000 without a CPE Authorized Service Outlet AND
 - ii. The service is required more than 100 miles from a CPE Authorized Service Outlet. The 100 mile limitation does not apply in the following states: Alaska, Arizona, Colorado, Hawaii, Idaho, Montana, Nebraska, Nevada, New Mexico, Oregon, Texas, Utah and Wyoming.
 - 3g. CPE shall be liable for damages to other original engine components or approved modifications proximately caused by a failure under warranty of an emission-related part covered by the ECS Warranty.
 - 3h. Throughout the ECS Warranty Period, CPE shall maintain a supply of warranted emission-related parts sufficient to meet the expected demand for such emission-related parts.
 - 3i. Any CPE Authorized and approved emission-related replacement part may be used in the performance of any ECS Warranty maintenance or repair and will be provided without charge to the owner. Such use shall not reduce CPE's warranty obligation.
 - 3j. Unapproved add-on or modified parts may not be used to modify or repair a CPE engine. Such use voids this ECS Warranty and shall be sufficient grounds for disallowing an ECS Warranty claim. CPE shall not be liable hereunder for failures of any warranted parts of a CPE engine caused by the use of such an unapproved add-on or modified part.

EMISSION-RELATED PARTS INCLUDE THE FOLLOWING: (using those portions of the list applicable to the engine)

Systems covered by this warranty	Parts Description
Fuel Metering System	Fuel regulator, Carburetor and internal parts
Air Induction System	Air cleaner, Intake manifold
Ignition System	Spark plug and parts, Magneto ignition system
Exhaust System	Exhaust manifold, catalytic converter
Miscellaneous Parts	Tubing, Fittings, Seals, Gaskets, and Clamps associated with these listed systems.
Evaporative Emissions	Fuel Tank, Fuel Cap, Fuel Lines (for liquid fuel and fuel vapors), Fuel Line Fittings, Clamps, Pressure Relief Valves, Control Valves, Control Solenoids, Electronic Controls, Vacuum Control Diaphragms, Control Cables, Control Linkages, Purge Valves, Gaskets, Liquid/Vapor Separator, Carbon Canister, Canister Mounting Brackets, Carburetor Purge Port Connector

TO OBTAIN WARRANTY SERVICE:

You must take your CPE engine or the product on which it is installed, along with your warranty registration card or other proof of original purchase date, at your expense, to any Champion Power Equipment dealer who is authorized by Champion Power Equipment, Inc. to sell and service that CPE product during his normal business hours. Alternate service locations defined in Section (3)(f.) above must be approved by CPE prior to service. Claims for repair or adjustment found to be caused solely by defects in material or workmanship will not be denied because the engine was not properly maintained and used.

If you have any questions regarding your warranty rights and responsibilities, or to obtain warranty service, please write or call Customer Service at Champion Power Equipment, Inc.

Champion Power Equipment, Inc.
6370 S Pioneer Way, Unit 101
Las Vegas, NV 89113
1-877-338-0999
Attn.: Customer Service
tech@championpowerequipment.com