



# OPERATOR'S MANUAL

MODEL #201092  
EARTH AUGER



### ACTIVATE YOUR WARRANTY

by registering your product:  
[championpowerequipment.com](http://championpowerequipment.com)

SERIAL NO.



 **1-877-338-0999**

or visit [championpowerequipment.com](http://championpowerequipment.com)

### WARNING

To reduce the risk of injury, the user must read and understand the operator's manual before using this product. If you do not understand the warnings and instructions in the operator's manual, do not use this product.

**SAVE THESE INSTRUCTIONS.** This manual contains important safety precautions which should be read and understood before operating the product. Failure to do so could result in serious injury. This manual should remain with the product.

Specifications, descriptions and illustrations in this manual are as accurate as known at the time of publication, but are subject to change without notice.

<b>TABLE OF CONTENTS</b>	
<b>Introduction</b> .....	<b>3</b>
<b>Safety Definitions</b> .....	<b>3</b>
<b>Important Safety Instructions</b> .....	<b>4</b>
Fuel Safety .....	5
Safety and Dataplate Labels .....	7
Safety Symbols .....	8
Operation Symbols .....	10
Quick Start Label Symbols .....	10
<b>Controls and Features</b> .....	<b>11</b>
Earth Auger .....	11
Parts Included .....	12
Tools Needed .....	12
<b>Assembly</b> .....	<b>13</b>
Unpacking .....	13
Assemble the Fishtail Point to the Auger Bit .....	13
To Assemble Auger Bit to Powerhead .....	13
Add Engine Oil .....	13
<b>Operation</b> .....	<b>14</b>
Fueling and Refueling .....	14
Starting the Engine .....	15
Stopping the Engine .....	17
Operating the Auger .....	17
Transporting the Auger .....	18
<b>Maintenance</b> .....	<b>18</b>
Cleaning the Earth auger .....	18
Changing the Engine Oil .....	19
Cleaning and Adjusting the Spark Plug(s) .....	19
Cleaning the Air Filter .....	20
Earth Blade and Fishtail Point .....	20
Adjusting the Governor .....	20
Maintenance Schedule .....	21
<b>Storage</b> .....	<b>21</b>
When storing 1 month or shorter: .....	21
When storing longer than a month: .....	21
<b>Specifications</b> .....	<b>22</b>
Earth Auger Specifications .....	22
Engine Specifications .....	22
Oil Specifications .....	22
Fuel Specifications .....	22
Temperature Specifications .....	22
<b>Troubleshooting</b> .....	<b>23</b>

 **FOR PARTS BREAKDOWN**

Search by model number at  
[championpowerequipment.com](http://championpowerequipment.com)

# INTRODUCTION

Congratulations on your purchase of a Champion Power Equipment (CPE) product. CPE designs, builds, and supports all of our products to strict specifications and guidelines. With proper product knowledge, safe use, and regular maintenance, this product should bring years of satisfying service.

Every effort has been made to ensure the accuracy and completeness of the information in this manual at the time of publication, and we reserve the right to change, alter and/or improve the product and this document at any time without prior notice.

CPE highly values how our products are designed, manufactured, operated, and serviced as well as providing safety to the operator and those around the earth auger. Therefore, it is IMPORTANT to review this product manual and other product materials thoroughly and be fully aware and knowledgeable of the assembly, operation, dangers and maintenance of the product before use. Fully familiarize yourself, and make sure others who plan on operating the product fully familiarize themselves too, with the proper safety and operation procedures before each use. Please always exercise common sense and always err on the side of caution when operating the product to ensure no accident, property damage, or injury occurs. We want you to continue to use and be satisfied with your CPE product for years to come.

When contacting CPE about parts and/or service, you will need to supply the complete model and serial numbers of your product. Transcribe the information found on your product's nameplate label to the table below

<b>CPE TECHNICAL SUPPORT TEAM</b>
1-877-338-0999
<b>MODEL NUMBER</b>
201092
<b>SERIAL NUMBER</b>
<b>DATE OF PURCHASE</b>
<b>PURCHASE LOCATION</b>

# SAFETY DEFINITIONS

The purpose of safety symbols is to attract your attention to possible dangers. The safety symbols, and their explanations, deserve your careful attention and understanding. The safety warnings do not by themselves eliminate any danger. The instructions or warnings they give are not substitutes for proper accident prevention measures.

**⚠ DANGER**

DANGER indicates a hazardous situation which, if not avoided, will result in death or serious injury.

**⚠ WARNING**

WARNING indicates a hazardous situation which, if not avoided, could result in death or serious injury.

**⚠ CAUTION**

CAUTION indicates a hazardous situation which, if not avoided, could result in minor or moderate injury.

**🗨 NOTICE**

NOTICE indicates information considered important, but not hazard-related (e.g., messages relating to property damage).

## IMPORTANT SAFETY INSTRUCTIONS

### ⚠ WARNING

Cancer and Reproductive Harm – [www.P65Warnings.ca.gov](http://www.P65Warnings.ca.gov)

### ⚠ DANGER

Earth auger exhaust contains carbon monoxide, a colorless, odorless, poisonous gas. Breathing carbon monoxide will cause nausea, dizziness, fainting or death. If you start to feel dizzy or weak, get to fresh air immediately.

**OPERATE THE EARTH AUGER OUTDOORS ONLY IN A WELL VENTILATED AREA AND POINT EXHAUST AWAY.**

NEVER operate the earth auger inside any building, including garages, basements, sheds or other confined spaces.

DO NOT allow exhaust fumes to enter a confined area through windows, doors, vents or other openings while operating the auger.

### ⚠ DANGER

Using an engine indoors **CAN KILL YOU IN MINUTES**. Engine exhaust contains carbon monoxide. This is a poison you cannot see or smell.

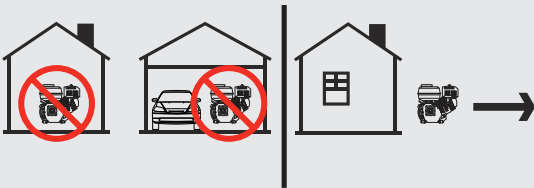

### ⚠ DANGER

Contact your local utility company to locate underground electrical lines or pipes prior to using this product. Failure to do so may result in serious personal injury or death and possible damage to equipment or property.

### ⚠ DANGER

DO NOT allow untrained individuals or children to use this unit.

### ⚠ DANGER

Rotating parts can entangle hands, feet, hair, clothing and/or accessories. Traumatic amputation or severe laceration can result.

Keep hands and feet away from rotating parts.

Tie up long hair and remove jewelry.

Operate equipment with guards in place.

DO NOT wear loose-fitting clothing, dangling drawstrings or items that could become caught.

### ⚠ DANGER

Rotating blades can cause severe bodily injury. Stop the engine and ensure blades have stopped rotating before installing/ changing parts or performing maintenance.

### ⚠ WARNING

Sparks can result in fire or electrical shock.

**When servicing the earth auger:**

Disconnect the spark plug wire and place it where it cannot contact the plug or any other metal object.

DO NOT check for spark with the plug removed.

Use only approved spark plug testers.

### ⚠ WARNING

Running engines produce heat. Severe burns can occur on contact. Combustible material can catch fire on contact.

DO NOT touch hot surfaces.

Avoid contact with hot exhaust gases.

Allow equipment to cool before touching.

Maintain at least 3 ft. (91.4 cm) of clearance on all sides to ensure adequate cooling.

Maintain at least 5 ft. (1.5 m) of clearance from combustible materials.

### ⚠ WARNING

Rapid retraction of the recoil cord will pull hand and arm towards the engine faster than you can let go. Broken bones, fractures, bruises or sprains could result.

When starting engine, pull the recoil cord slowly until resistance is felt and then pull rapidly to avoid kickback.

**⚠ WARNING**

- Clear the work area before each use. Remove all objects such as rocks, broken glass, nails, wire, or string which can be thrown or become entangled in the machine.
- Always wear eye protection with side shields marked to comply with ANSI Z87.1. Failure to do so could result in objects being thrown into your eyes and other possible serious injuries.
- Keep all bystanders, children, and pets at least 50' (15m) away when operating the earth auger.
- Always wear sound protection (ear muffers or ear plugs) to reduce the risk of hearing loss associated with long term engine sound level(s).
- Always wear heavy long pants, boots, gloves, and a long-sleeve shirt. Do not wear loose clothing, jewelry, short pants, sandals, or go barefoot. Secure long hair so it is above shoulder level to prevent entanglement in rotating parts.
- Do not operate this unit when you are tired, ill, or under the influence of alcohol, drugs, or medication.
- Do not operate in poor lighting.
- Always wear a face filter mask in dusty conditions to reduce the risk of injury associated with the inhalation of dust.
- Keep firm footing and balance. Maintain a firm grip on the handle with both hands while using the auger.
- Do not overreach. Overreaching can result in loss of balance or exposure to hot contact surfaces or rotating parts.
- This engine is equipped with a spark arrestor. Never operate the unit without a spark arrestor screen.
- Although the earth auger contains a spark arrester, maintain a minimum distance of 5 ft. (1.5 m) from dry vegetation to prevent fires.
- Always inspect the unit before each use for loose fasteners, fuel leaks, etc. Replace damaged parts.
- Use only identical manufacturer's replacement parts and accessories. Use of any other replacement parts may create a hazard or cause product damage and void your warranty.
- Maintain the equipment per maintenance instructions located in this Operator's Manual

**⚠ CAUTION**

Prolonged exposure to vibrations, also known as vibration white finger, through use of gasoline-powered equipment, such as this auger, could cause blood vessel or nerve damage in fingers, hands, and joints. If symptoms occur such as numbness, or loss of feeling in the fingers, hands, or joints, discontinue the use of this auger and seek medical attention.

**Fuel Safety****⚠ DANGER**

**GASOLINE AND GASOLINE VAPORS ARE HIGHLY FLAMMABLE AND EXPLOSIVE.**

Fire or explosion can cause severe burns or death.

**Gasoline and gasoline vapors:**

- Gasoline vapors are highly flammable and explosive.
- Gasoline vapors can cause a fire or explosion if ignited.
- Gasoline is a liquid fuel and the resulting gasoline vapors can ignite and cause a fire or explosion.
- Gasoline is a skin irritant and needs to be cleaned up immediately if spilled on skin or clothes.
- Gasoline has a distinctive odor, this will help detect potential leaks quickly.
- In any petroleum gas fire, flames should not be extinguished unless by doing so the fuel supply valve can be turned OFF. This is because if a fire is extinguished and a supply of fuel is not turned OFF, then an explosion hazard could be created.
- Gasoline vapors expand and contract with ambient temperatures. Never fill the gasoline tank past the red FULL indicator on the fuel filter, as gasoline vapors need room to expand if temperatures rise.

**⚠ WARNING****When adding or removing gasoline:**

Do not light or smoke cigarettes.

Always stop the engine and allow to cool for a minimum of two minutes before refueling.

Always loosen gasoline cap slowly to release vapor pressure and to keep fuel from escaping around the gasoline cap.

Always replace and tighten the gasoline cap securely after fueling.

Never remove the gasoline cap or add gasoline while the engine is running or when the engine is hot.

Only fill or drain gasoline outdoors in a well-ventilated area.

Do not pump gasoline directly into the earth auger at the gas station.

Always store gasoline in an EPA/CARB compliant container or to transfer the gasoline to the earth auger.

Do not overfill the gasoline tank.

Always keep gasoline away from sparks, open flames, pilot lights, heat and other sources of ignition.

**⚠ WARNING****When starting the earth auger:**

Do not attempt to start a damaged earth auger.

Always check that the gasoline cap, air filter, spark plug, fuel lines and exhaust system are properly in place.

Always allow spilled gasoline to evaporate fully before attempting to start the engine.

Always be certain that the earth auger is resting firmly on level ground.

**⚠ WARNING****When operating the earth auger:**

Do not move or tip the earth auger during operation.

**⚠ WARNING****When transporting or servicing the earth auger:**

Always check that the fuel valve is in the OFF position and the gasoline tank is empty.

Disconnect the spark plug wire.

**⚠ WARNING****When storing the earth auger:**

Store away from sparks, open flames, pilot lights, heat and other sources of ignition.

Do not store earth auger or gasoline near furnaces, water heaters, or any other appliances that produce heat or have automatic ignitions.

**⚠ DANGER**

Never place a gasoline container, gasoline tank, LPG cylinder or any combustible material in the path of the exhaust stream during operation of the engine.

**⚠ WARNING**





Never use a gasoline container, gasoline tank, or any other fuel item that is broken, cut, torn or damaged.

### Safety and Dataplate Labels

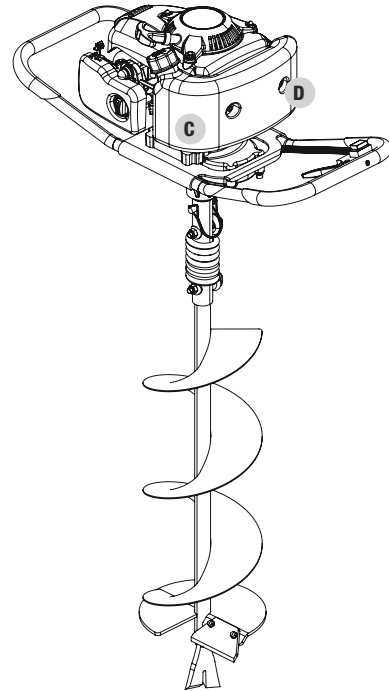
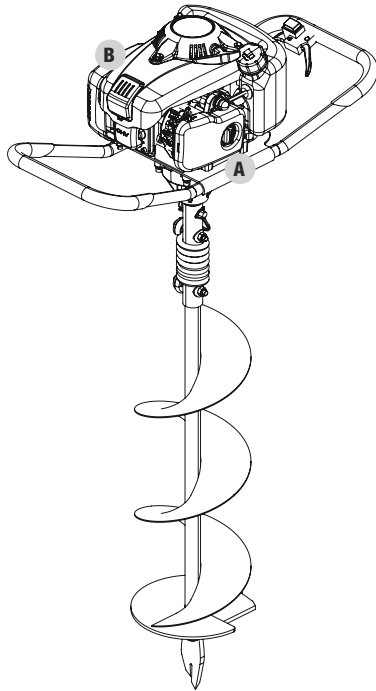
These labels warn you of potential hazards that can cause serious injury. Read them carefully.

If a label comes off or becomes hard to read, contact Technical Support Team for possible replacement.

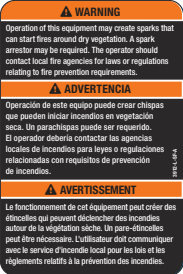



	LABEL	DESCRIPTION
A		Engine Danger Icon
B		Hot Surface Warning
C		Spark Arrestor Warning
D		Dataplate

## Safety Symbols

Some of the following symbols may be used on this product. Please study them and learn their meaning. Proper interpretation of these symbols will allow you to more safely operate the product.

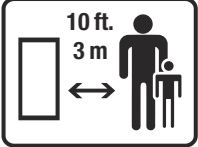
SYMBOL	MEANING
	<p><b>Read Operator's Manual.</b> To reduce the risk of injury, user must read and understand operator's manual before using this product.</p>
	<p><b>Eye and Ear Protection.</b> Always wear safety goggles or safety glasses with side shields, and as necessary a full face-shield as well as full ear protection when operating this product.</p>
	<p><b>Footwear.</b> Always wear safety shoes or heavy boots when operating the machine.</p>
	<p><b>Gloves.</b> Always wear nonslip, heavy-duty protective gloves when operating this product.</p>
	<p><b>Safety Alert.</b> Precautions that involve your safety.</p>
	<p><b>Risk of Fire.</b> Fuel and its vapors are extremely flammable and explosive. Fire can cause severe burns or death. Do not add fuel while the product is operating or still hot.</p>
	<p><b>Hot Surface.</b> To reduce the risk of injury or damage, avoid contact with any hot surface</p>
	<p><b>Open Flame alert.</b> Fuel and its vapors are extremely flammable and explosive. Keep fuel away from smoking, open flames, sparks, pilot lights, heat, and other ignition sources.</p>

SYMBOL	MEANING
	<p><b>Toxic Fumes.</b> The engine exhaust from this product contains chemicals known to the state of California to cause cancer and birth defects and other reproductive harm.</p> <p><b>Risk of Asphyxiation.</b> This engine emits carbon monoxide, an odorless, colorless poison gas. Breathing carbon monoxide can cause nausea, fainting or death. Use only in a well ventilated area.</p>
	<p><b>Clearance.</b> Keep all objects including others at least 10 feet (3m) from this machine. Only one person should operate the earth auger.</p>
	<p><b>Amputation Hazard.</b> Rotating parts can entangle hands, feet, hair, clothing and/or accessories. Traumatic amputation or severe laceration can result.</p>
	<p><b>Serious Personal Injury or Property Damage.</b> Before inspecting, cleaning, or servicing the auger, shut off the engine. Wait for all moving parts to stop, disconnect spark plug wire and move it away from the spark plug. Failure to follow these instructions could result in personal injury or damage to the auger.</p>

### Operation Symbols

Some of the following symbols may be used on this product. Please study them and learn their meaning. Proper interpretation of these symbols will allow you to more safely operate the product.

SYMBOL	MEANING
	Engine Switch ON
	Engine Switch OFF
	Choke
	Run

SYMBOL	MEANING
	Throttle: Slow
	Throttle: Fast

### Quick Start Label Symbols

Some of the following symbols may be used on this product. Please study them and learn their meaning. Proper interpretation of these symbols will allow you to more safely operate the product.



#### Starting the Engine

- Check Oil Level.**  
Recommended oil is 5W-30. The engine can be seriously damaged without oil. Always check the oil level before using. The machine must be resting firmly on level ground when checking.
- Check gasoline level.**  
When adding gasoline, use a minimum octane rating of 87 and an ethanol content of 10% or less by volume.
- Press the **engine switch** to the “ON” position.
- Primer Bulb: for cold engine, press the **primer bulb** 7-10 times, or until bulb is full of fuel. (not required for a warm engine).
- Choke: For a cold engine, move the **choke lever** to the “CHOKE” position. (not required for a warm engine)
- Pull the **recoil starter**.
- Allow the engine to idle for 3-10 seconds.
- Move the **choke lever** to the “RUN” position.

#### Stopping the Engine

- Press the **engine switch** to the “OFF” position.

## CONTROLS AND FEATURES

Read this operator's manual before operating your earth auger. Familiarize yourself with the location and function of the controls and features. Save this manual for future reference.

### Earth Auger

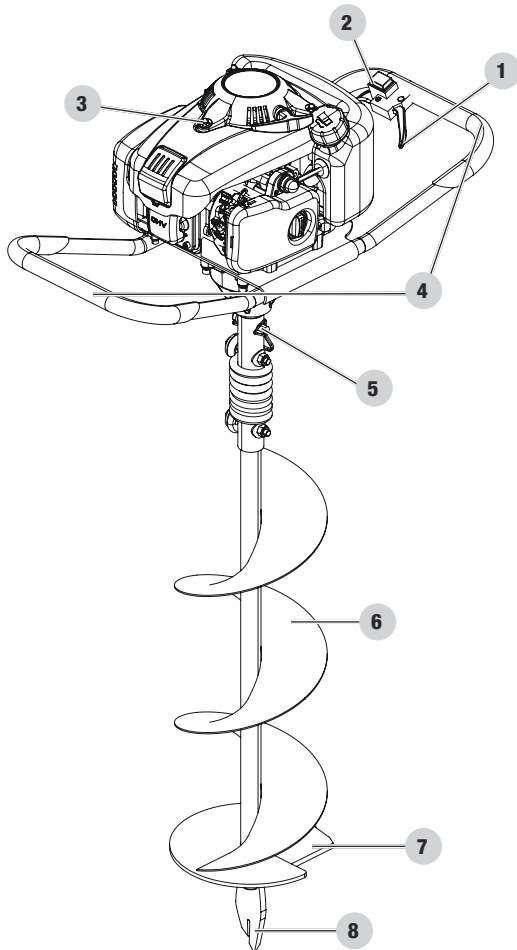

#### Auger

1. Throttle/Speed control
2. Engine ON/OFF switch
3. Engine
4. Soft grip handles
5. Clevis pin with double wire snap
6. 8 in. (20.3 cm) Auger bit
7. Earth blade (replaceable)
8. Fishtail bit point (replaceable)

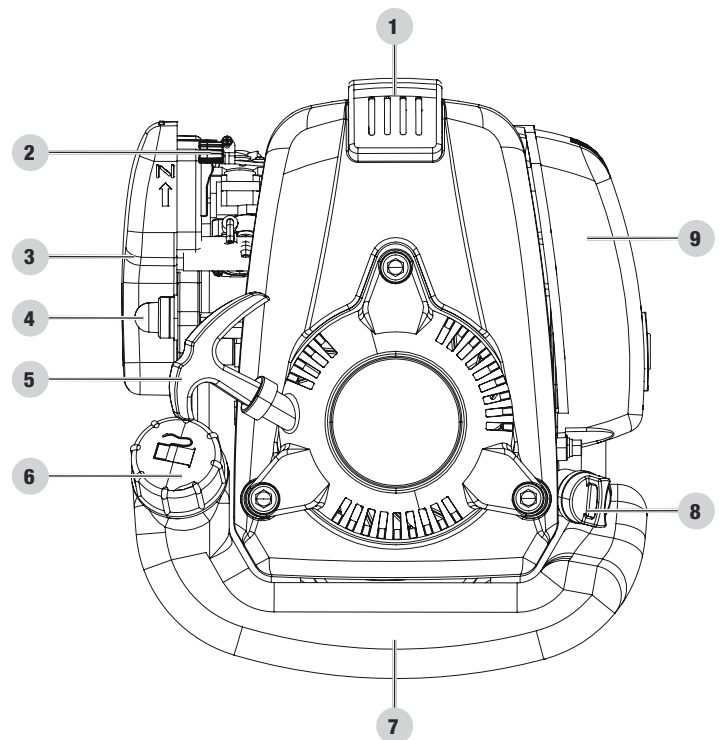

#### Engine

1. Spark plug
2. Choke lever
3. Air filter
4. Fuel primer bulb
5. Recoil starter handle
6. Fuel tank cap
7. Fuel tank
8. Oil fill cap/dipstick
9. Muffler

## Parts Included

### Assembly Parts

Part	Part Qty.	Hardware Needed	Hardware Qty.	Tool Needed
53.5 cc Auger Powerhead, handle bars and grips	1	Clevis pin	1	N/A
8 in. (20.3 cm) Auger bit	1	N/A		N/A
Fishtail point	1	N/A		Adjustable wrench

### Accessories

Spark plug socket ..... 1

Engine oil ..... 0.3 US qt. (240 mL)

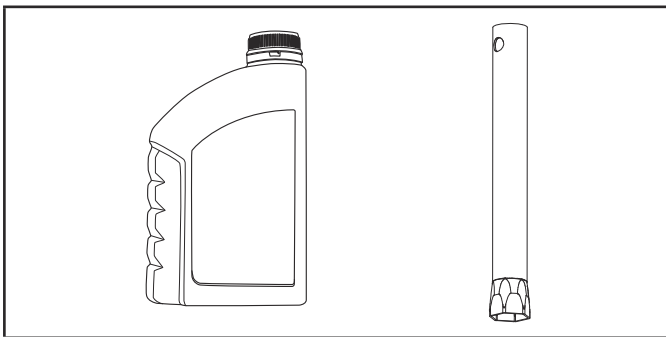

### Tools Needed

- Adjustable wrench

## ASSEMBLY

Your earth auger requires some assembly. This unit ships from our factory without oil. It must be properly serviced with fuel and oil before operation.

If you have any questions regarding the assembly of your earth auger, call our Technical Support Team at 1-877-338-0999. Please have your serial number and model number available.

### Unpacking

1. Set the shipping carton on a solid, flat surface.
2. Remove all contents from the carton.

### Assemble the Fishtail Point to the Auger Bit

1. Insert the threaded end of the fishtail point into the threaded hole on the end of the auger bit and rotate clockwise to hand tighten.

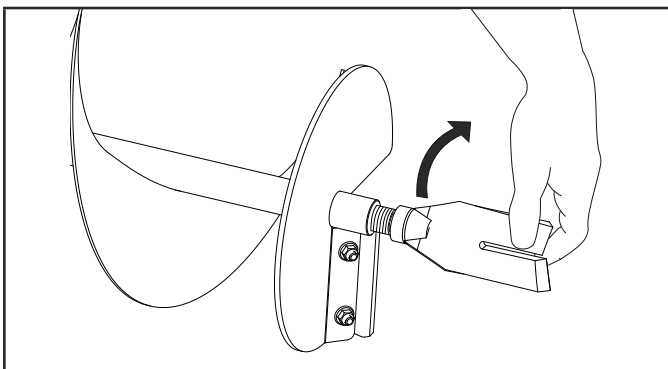

2. To tighten securely, grasp the auger bit shaft with one hand while placing an adjustable wrench on the fishtail bit point and tighten until it is securely in place.

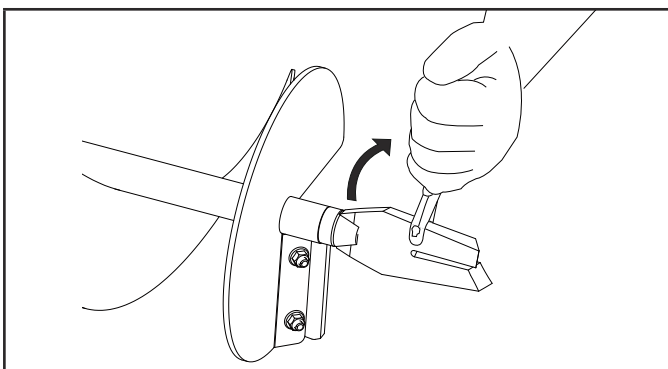

### To Assemble Auger Bit to Powerhead

1. Insert the power head output shaft into the auger bit shaft and align the hole in the output shaft with the holes in the auger bit shaft.
2. Insert the Ø9.5 x 45 mm clevis pin completely through the aligned holes on the powerhead output shaft and auger bit tube so it is extended out of the other side.
3. Place the open triangle looped Clevis pin end of the double wire snap around the exposed end of the Ø9.5 x 45 mm clevis pin to secure the bit to the power head output shaft.

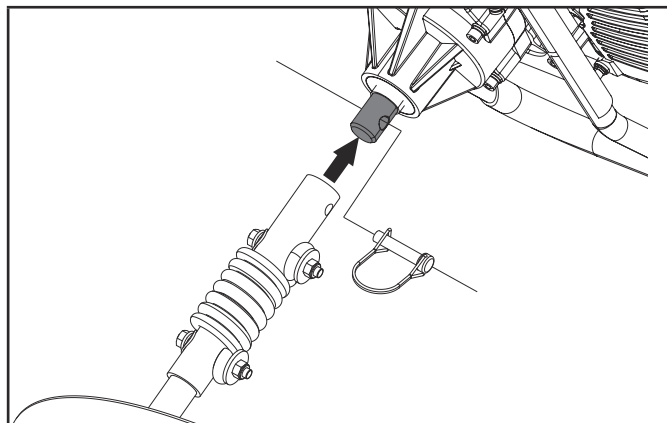

### Add Engine Oil

#### ⚠ WARNING

DO NOT attempt to crank or start the engine before it has been properly filled with the recommended type and amount of oil. Damage to the engine as a result of failing to follow these instructions will void your warranty.

#### 🗨 NOTICE

The recommended oil type for typical use is **5W-30 automotive oil**. However, using the listed conventional oils shown in the “Recommended Engine Oil Type” chart may be used for typical use including the first 5 hours of the break-in run time period of the engine.

If running engine in extreme temperatures, refer to the “Recommended Engine Oil Type” chart.

Recommended Engine Oil Type	
°F	-20    0    20    40    60    80    100    120
°C	-28.9    -17.8    -6.7    4.4    15.6    26.7    37.8    48.9
Ambient temperature	

1. Place the earth auger on a flat, level surface with the oil fill cap facing upward.
2. Remove oil fill cap/dipstick to add oil.
3. Using a funnel, add up to 0.3 US qt. (240 mL) of oil (included) and replace oil fill cap/dipstick. **DO NOT OVERFILL.**

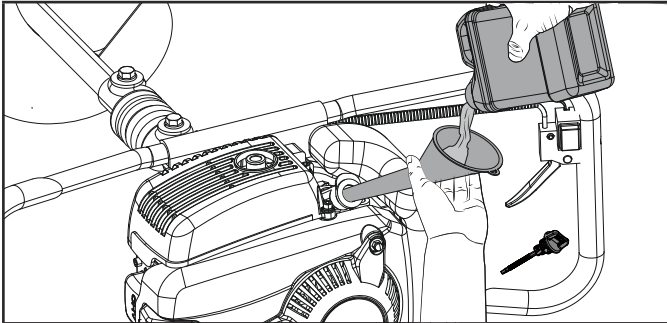

4. Check engine oil level at every use and add as needed.

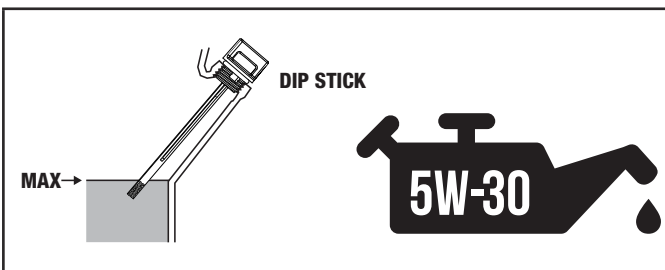

#### NOTICE

Check oil level often during the break-in period. Refer to the *Maintenance* section for recommended service intervals.

#### NOTICE

We consider the first 5 hours of run time to be the break-in period for the engine. During the break in period we recommend using standard automotive non-synthetic blended oils. After the break in period synthetic lubricant can be used but is not required. Adjusting throttle setting will increase/decrease engine speed helping to seat piston rings. Avoid bogging or lugging the engine down and avoid prolonged running at constant RPM. After the 5 hour break-in period, change the oil. Using synthetic lubricants does not increase the recommended oil change interval.

#### NOTICE

Synthetic oil may be used after the 5 hour initial break-in period. Using synthetic oil does not decrease the recommended oil change interval. Full synthetic 5W-30 oil will aid in starting in cold ambient < 41° F (5° C) temperatures.

## OPERATION

### Fueling and Refueling

#### WARNING

- Do not smoke while fueling or mixing fuel.
- Always mix and pour fuel outdoors away from electrical appliances where there are no sparks or open flames.
- Never add fuel to a running or hot engine.
- Always wait 15 minutes to cool down engine before refueling.

#### NOTICE

DO NOT USE E15 or E85 (fuel containing ethanol greater than 10%) in this engine. Use of gasoline containing more than 10% ethanol will damage the engine and void your warranty.

### Filling the Fuel Tank

1. Place the earth auger on a flat, level surface, resting on the handle with the throttle/speed control assembled to it so that the fuel tank cap is pointing upward.

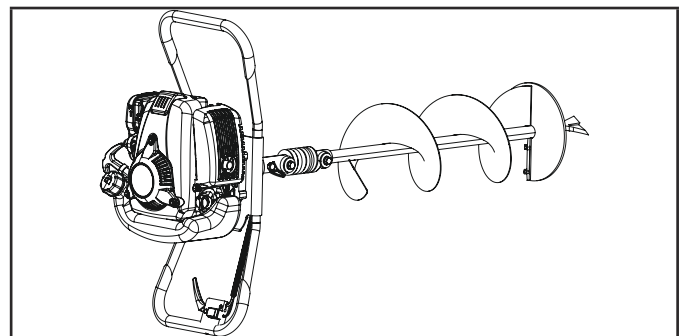

2. Clean the surface around the fuel cap to prevent contamination.
3. Loosen the fuel cap slowly by turning counterclockwise.
4. Pour the fuel carefully into the tank.

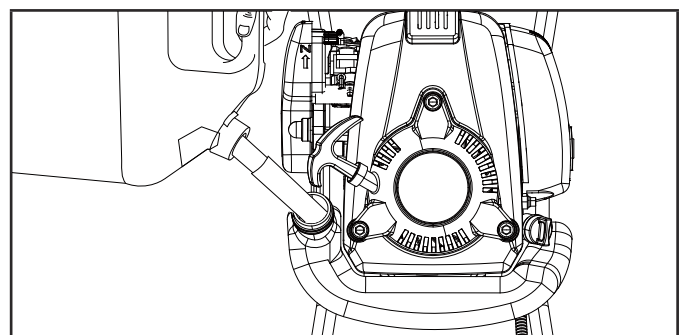

5. Only fill the fuel tank to 80% of the full capacity. Fuel level can be seen via the clear fuel tank.
6. Clean and inspect the fuel cap gasket before replacing the fuel cap.
7. Replace the fuel cap and tighten it by turning it clockwise.
8. Wipe spilled fuel from the product.
9. If you spill fuel on the unit, wait 10 minutes for evaporation after wiping and move at least 10 ft. (3 m) away from the spilled refueling area before starting the product.

### NOTICE

It is normal for smoke to be emitted from a new engine during first use.

## Starting the Engine

### Start a Cold Engine

1. Place the handlebar with the throttle/speed control assembly side flat to the ground surface.

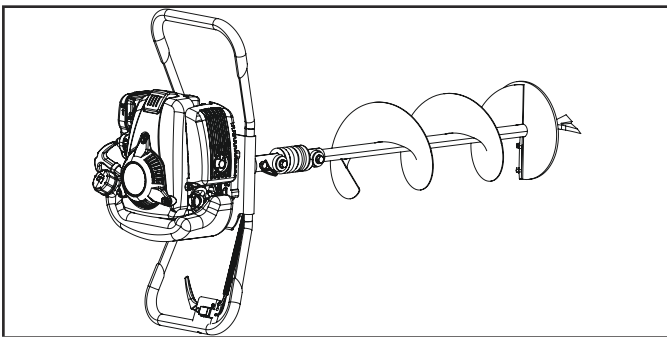

2. Move the engine On/Off switch to the "ON" (I) position.

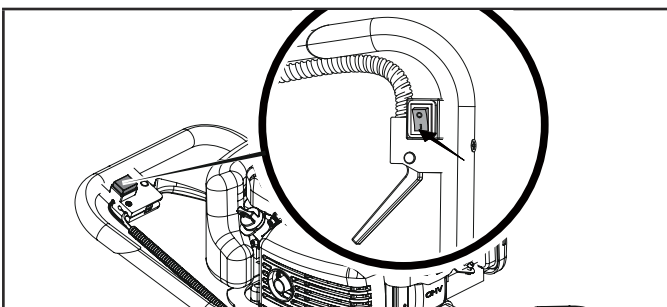

3. Slowly press the primer bulb 7-10 times or until fuel is visible.

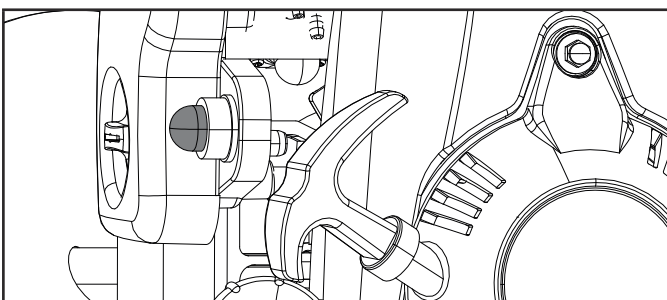

4. Set the choke lever to the "CHOKE" position.

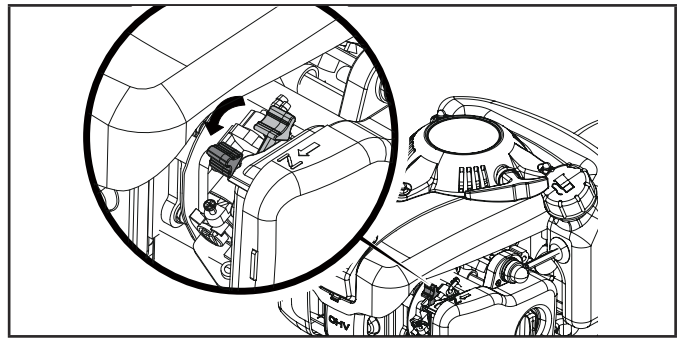

5. While standing on the operator side of the auger, place your foot on the handlebar that is on the ground to stabilize the unit. Grip the other handlebar with the other hand and tilt the auger so that the auger bit is off of the ground.

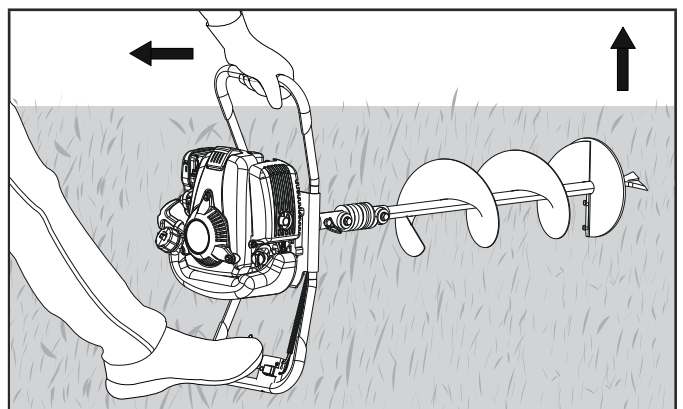

6. Holding the unit firmly, pull the recoil starter grip 2 times to prime with fuel, then pull until engine starts. Use short pulls and do not allow the rope to snap back. Do not pull more than 6 times.

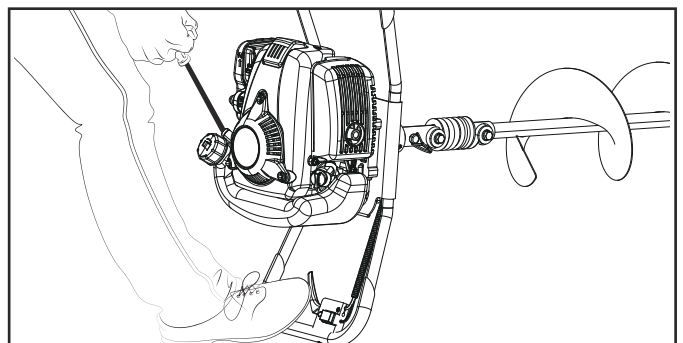

- Once the engine starts, stand the auger up in the vertical position and allow to run for 3-10 seconds.

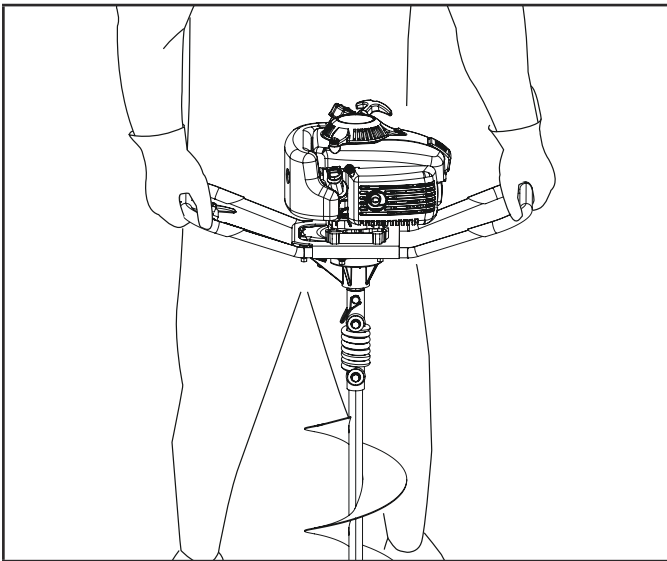

- After the engine runs for 3-10 seconds, move the choke lever to the "RUN" position.

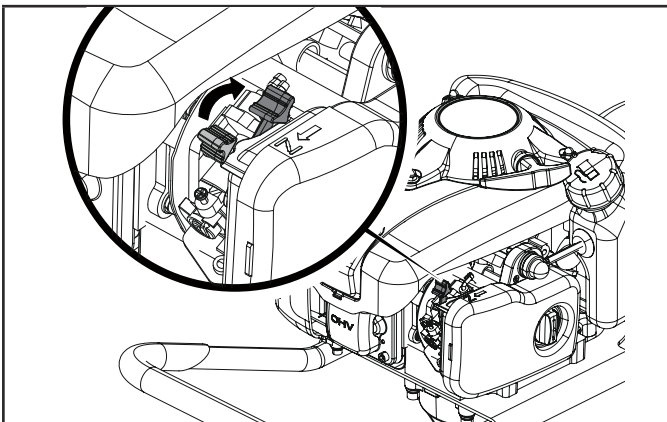

### Start a Warm Engine

- Place the handlebar with the throttle/speed control assembly side flat to the ground surface.

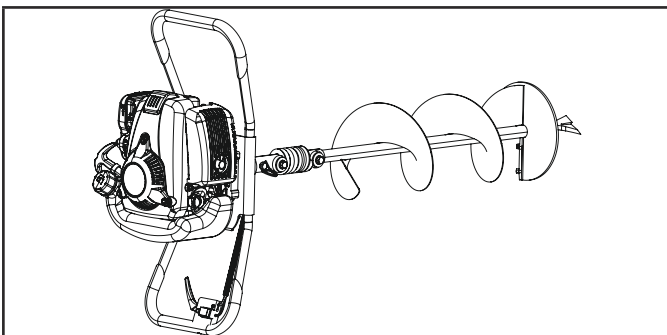

- Move the engine On/Off switch to the "ON" (I) position.

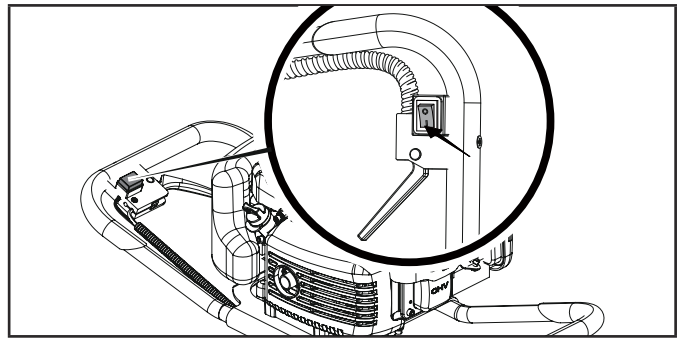

- Ensure that the choke lever is in the "RUN" position.

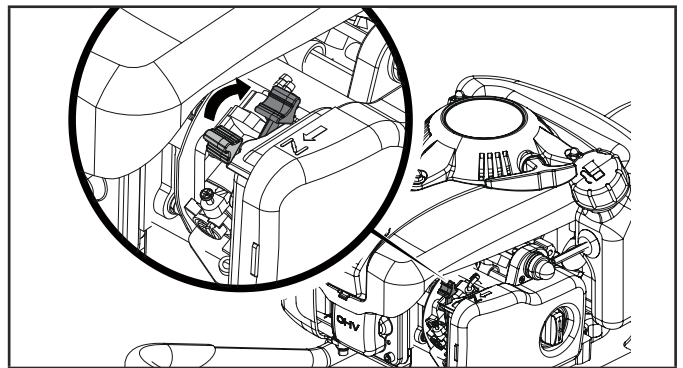

- While standing on the operator side of the auger, place your foot on the handlebar that is on the ground to stabilize the unit. Grip the other handlebar with the other hand and tilt the auger so that the auger bit is off the ground.

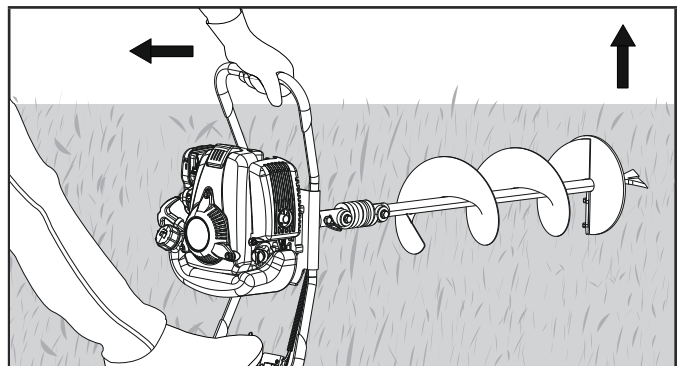

- Holding the unit firmly, pull the recoil starter grip until engine starts. Use short pulls and do not allow the rope to snap back.

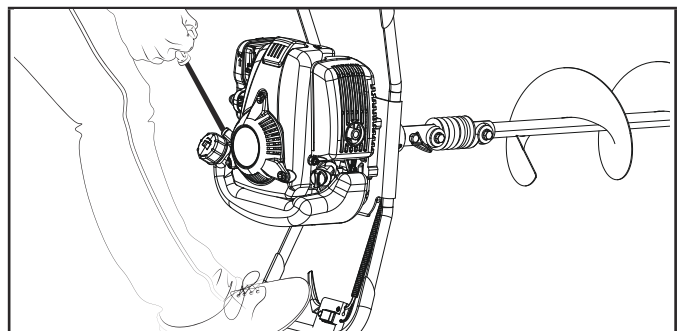

- Once the engine starts, stand the auger up in the vertical position.

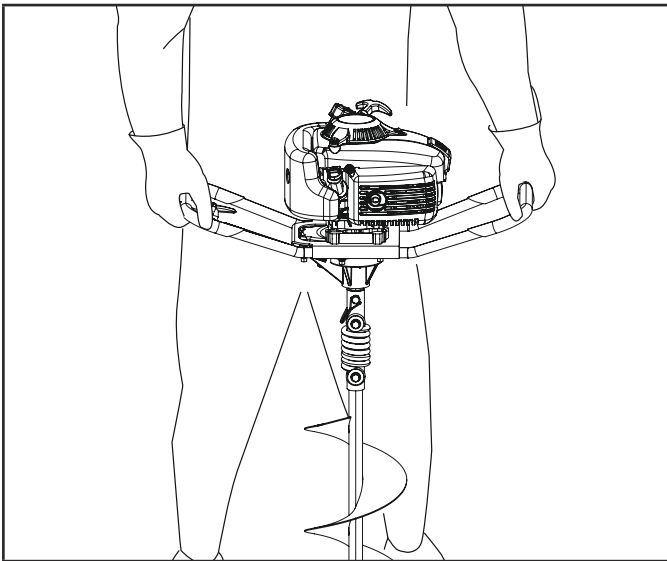

### ⚠ WARNING

Rapid retraction of the recoil cord could pull your hand and arm towards the engine faster than you can let go. Broken bones, fractures, bruises or sprains could result.

### 🗨 NOTICE

Manually adjusting or turning the choke lever to the CHOKE position during idle will cause the engine to stop.

### 🗨 NOTICE

If the engine does not start, return to the "Start a Cold Engine" and repeat the steps that follow.

## Stopping the Engine

- Release the throttle/speed control to stop the auger bit from rotating.

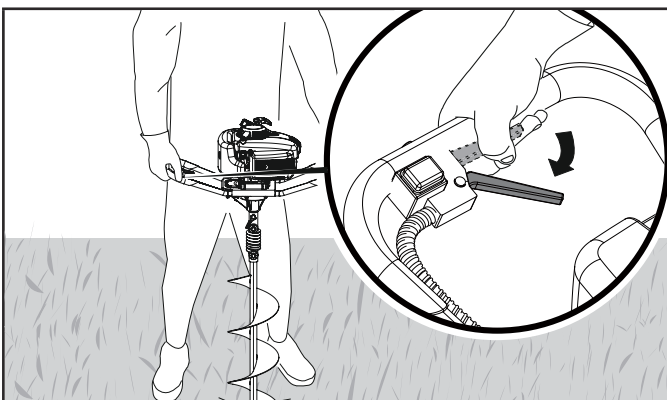

### ⚠ CAUTION

The auger bit will continue to rotate for a few seconds after the throttle/speed control is released.

- Move the engine On/Off switch to the "OFF" (O) position.

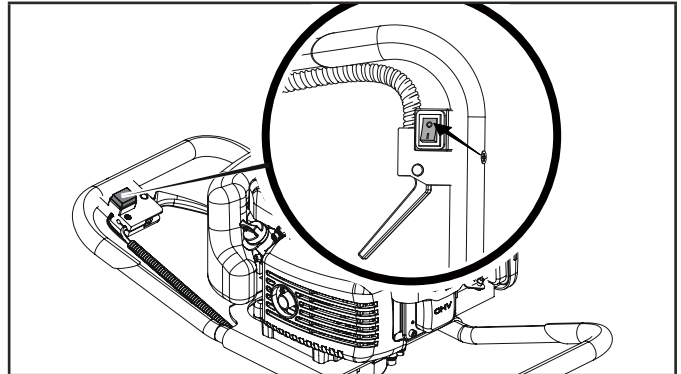

### ⚠ WARNING

If the engine does not stop when the engine switch is moved to the "STOP" position, release the throttle. Allow the engine to idle. Put the auger down and slide the choke lever to cold start (closed) position.

## Operating the Auger

- Holding the unit in the vertical position, place the tip of the fishtail bit point at the desired drilling location.

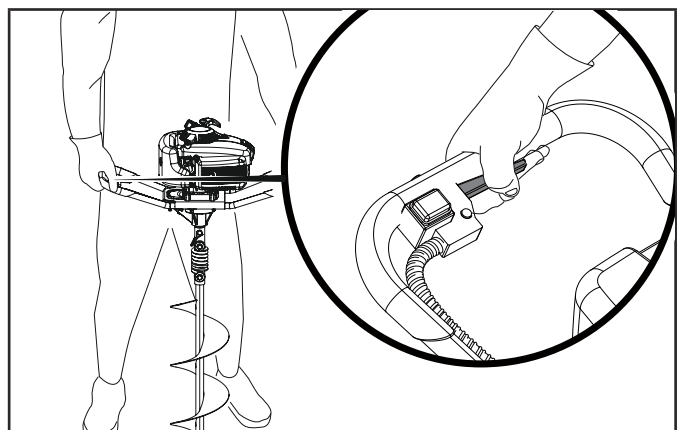

- Engage the throttle/speed control and first start digging the hole at a slow speed to get a good engagement with the soil.
- Gradually increase the speed as the auger bit enters the soil.
- As the auger bit penetrates deeper into the soil, occasionally lift the auger bit partially up out of the hole to disperse the loose soil. This will keep the hole free of loose soil and prevent the auger bit from becoming stuck in the hole. This will also reduce the time it takes to dig a hole and prevent overworking the engine.

**⚠ CAUTION**

If the auger bit will not turn in a hole, turn engine off and remove auger bit from the hole. Check auger bit for damage and remove any debris from auger bit or hole. Secure spark plug boot away from the engine and frame to alleviate potential arcing.

**Transporting the Auger****⚠ WARNING**

Before transporting the auger, shut off engine and wait for all moving parts to stop. Failure to follow these instructions could result in personal injury or property damage.

1. Disassemble the auger bit from the power head by removing the open triangle looped end of the double wire snap from the exposed end of the  $\varnothing$  9.5 x 45 mm clevis pin and removing the clevis pin from the auger bit and power head output shaft. This will disengage the bit from the power head output shaft.

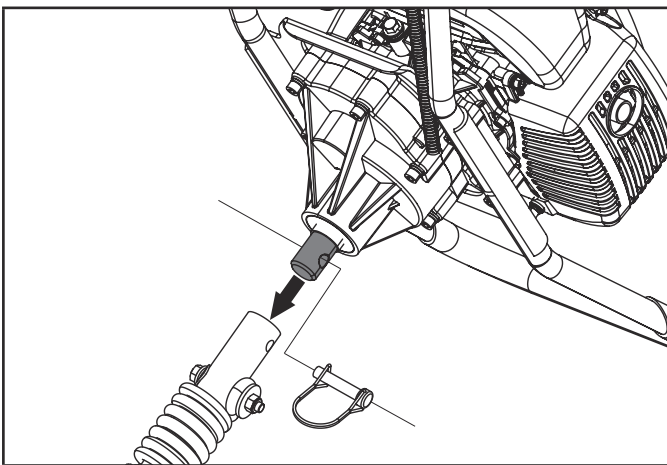

2. Carry the power head by the handle that does not have the throttle/speed control with the recoil starter against your leg so the fuel tank cap is pointed skyward while carrying the auger bit in the other hand, held by the shaft.

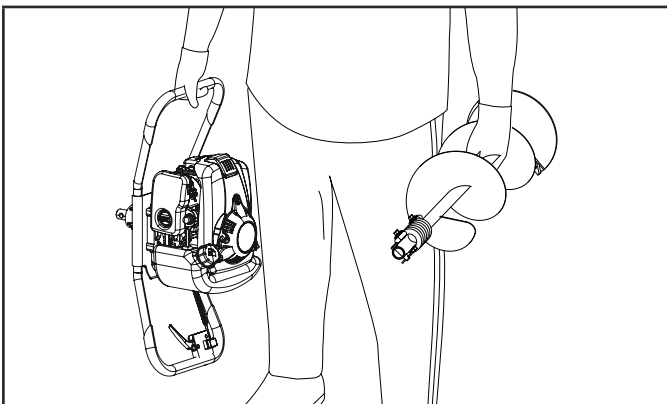
**MAINTENANCE**

Make certain that the earth auger is kept clean and stored properly. Only operate the unit on a flat, level surface in a clean, dry operating environment. DO NOT expose the unit to extreme conditions, excessive dust, dirt, moisture or corrosive vapors.

The owner/operator is responsible for all periodic maintenance.

Complete all scheduled maintenance in a timely manner.

Correct any issue before operating the earth auger.

For service or parts assistance, contact our Technical Support Team at 1-877-338-0999.

**⚠ WARNING**

Never operate a damaged or defective earth auger.

**⚠ WARNING**

Improper maintenance will void your warranty.

**⚠ WARNING**

Before inspecting, cleaning, or servicing the earth auger, shut off the engine. Wait for all moving parts to stop. Failure to follow these instructions could result in personal injury or damage to the earth auger.

**🗨 NOTICE**

For Emission control devices and systems, read and understand your responsibilities for service as stated in the Emission Control Warranty Statement of this manual.

**Cleaning the Earth auger****⚠ CAUTION**

DO NOT spray earth auger directly with water.

Water can contaminate the fuel system and can enter the engine through the cooling slots and damage the engine.

1. Use a damp cloth to clean exterior surfaces of the earth auger.
2. Use a soft bristle brush to remove dirt and oil.
3. Use an air compressor (25 PSI) to clear dirt and debris from the earth auger.
4. Inspect all air vents and cooling slots to ensure that they are clean and unobstructed.

## Changing the Engine Oil

### ⚠ WARNING

DO NOT attempt to crank or start the engine before it has been properly filled with the recommended type and amount of oil. Damage to the engine as a result of failing to follow these instructions will void your warranty.

### 🗨 NOTICE

The recommended oil type is 5W-30 automotive oil.

Change oil when the engine is warm. Refer to the *Oil Specification* to select the proper grade for your operating environment.

1. Place the earth auger on a flat, level surface with the drain plug facing downward.
2. Clean around the oil drain plug to prevent dirt from falling into the crankcase. Remove oil drain plug with a 10 mm socket (not included).

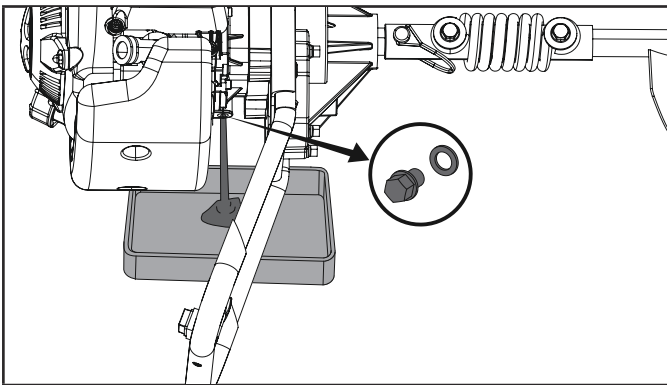

3. Allow the oil to drain completely into an appropriate container.
4. Replace the oil drain plug.
5. Remove the oil fill cap/dipstick to add oil.
6. Add oil according to *Add Engine Oil* in *Assembly* section. DO NOT OVERFILL. Oil not included for routine maintenance.

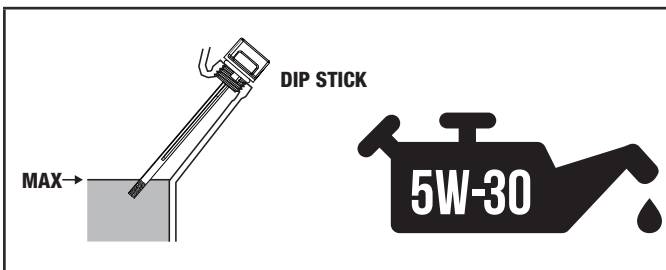

7. Dispose of used oil at an approved waste management facility.

## Cleaning and Adjusting the Spark Plug(s)

1. Depress the tab on the spark plug cover then lift upward removing the cover.

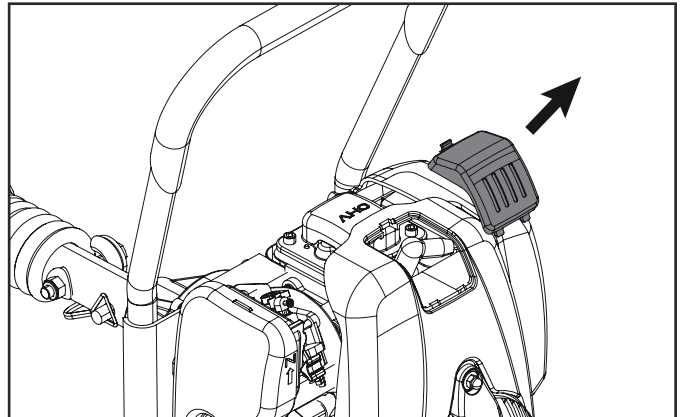

2. Remove the spark plug cable from the spark plug.

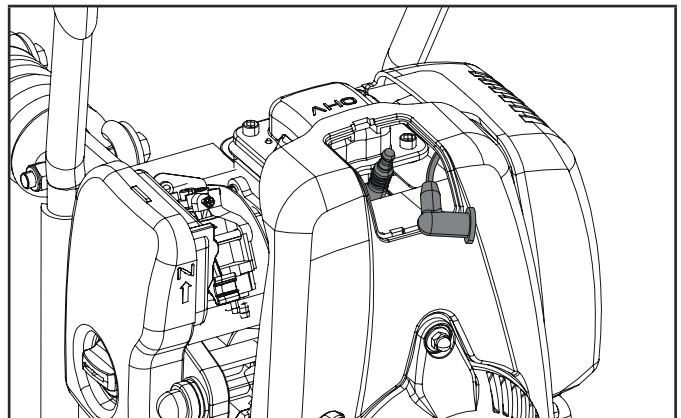

3. Use a spark plug socket tool, or a 41/64 in. (16 mm) socket to remove the plug.

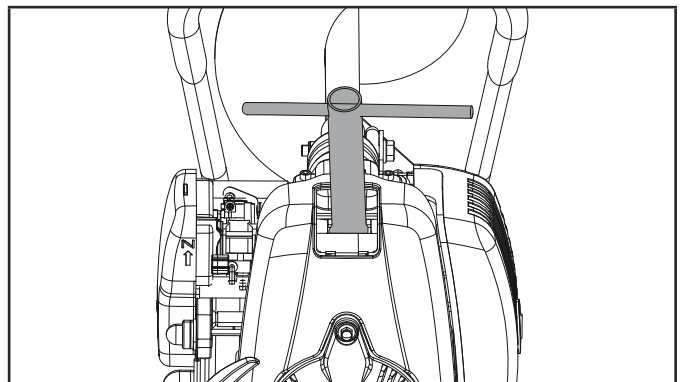

4. Inspect the electrode on the plug. It must be clean and not worn to produce the spark required for ignition.
5. Make certain the spark plug gap is set within limits. Refer to the *Specifications* section for values.

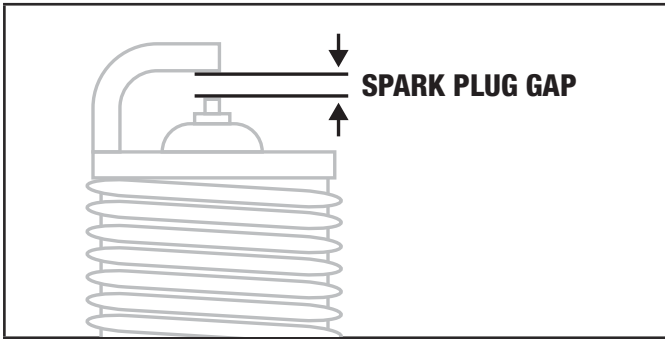

6. Refer to the spark plug types in *Specifications* when replacing the plug.
7. Carefully thread the plug into the engine.
8. Use a spark plug socket tool, or a 41/64 in. (16 mm) socket to install the plug.
9. Attach the spark plug wire to the plug.

### Cleaning the Air Filter

1. Using your fingers, turn the knob on the air filter cover counterclockwise to loosen the air filter cover.

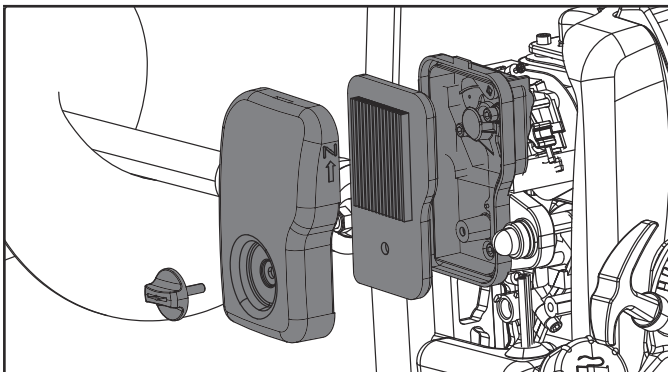

2. Remove the paper air filter element.
3. Clean filter by gently tapping it on a flat surface. If very dirty, replace with a new filter.
4. Place the air filter back into the assembly.
5. Reattach the air filter cover.

### Earth Blade and Fishtail Point

#### ⚠ WARNING

Use only the manufacturer's replacement part intended for this auger bit. Do not use any other earth blade, fishtail point or other branded replacement part to this auger bit which could result in serious personal injury. Replace worn or damaged earth blade or fishtail point.

1. Remove the mounting hardware (bolts and nuts), and take off the earth blade.

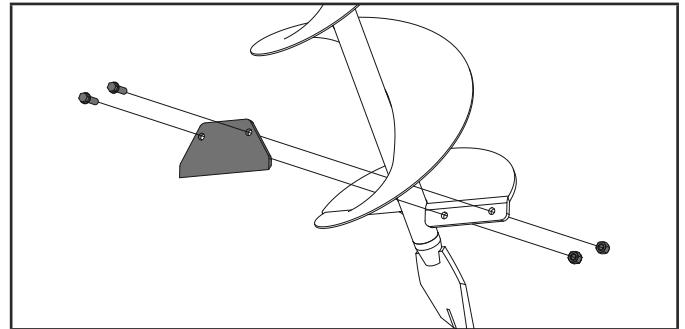

2. Install new earth blade with new mounting hardware.
3. Tighten the bolts to secure blade.
4. To replace the fishtail point, use an adjustable wrench to break it loose.

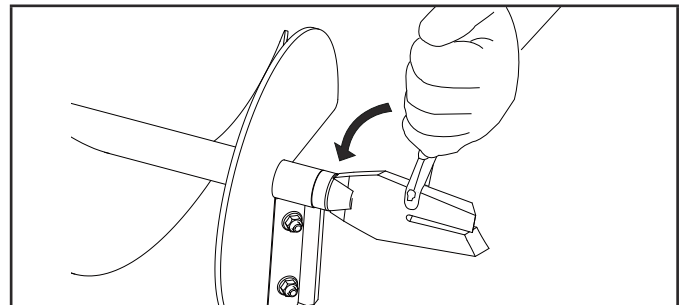

### Adjusting the Governor

#### ⚠ WARNING

Tampering with the factory set governor will void your warranty.

The air-fuel mixture is not adjustable. Tampering with the factory set governor can damage your earth auger. Contact our Technical Support Team at 1-877-338-0999 for all other service and/or adjustment needs.

## Maintenance Schedule

Follow the service intervals indicated in the following maintenance schedule.

Service your earth auger more frequently when operating in adverse conditions.

Contact our Technical Support Team at 1-877-338-0999 to locate the nearest CPE certified service dealer for your earth auger or engine maintenance needs.

### BEFORE USE

- Check oil level
- Wipe up fuel leaks, fuel spillage.
- Inspect and clean fuel tank.

### 25 HOURS

- Clean cylinder fins and intake cooling vent.
- Inspect and clean the air filter.

### EVERY 50 HOURS OR EVERY SEASON

- Change oil
- Clean and readjust spark plug gap (gap: 0.6 – 0.8 mm [0.024 – 0.031 in.]), and replace if necessary.
- Inspect and clean the air filter.

### ANNUALLY

- Replace spark plug.

## STORAGE

### WARNING

Never store the auger indoors or next to appliances where there is a source of heat, open flame, spark or pilot light as these conditions can ignite gasoline vapors. DO NOT store the auger near fertilizer or any corrosive material. Even with an empty fuel tank, gasoline vapors could ignite. When storing the auger for short or long periods of time, always be sure that the engine switch (where applicable) and the fuel valve (where applicable) are set in the “OFF” position.

### NOTICE

You can store the unit with ethanol free 50:1 TruFuel gasoline which is pretreated with advanced stabilizers to safeguard against water absorption during storage.

### NOTICE

The engine works well with 10% or less ethanol blended gasoline. When using ethanol-blended gasoline there are some issues worth noting:

Ethanol-blended gasoline can absorb more water than gasoline alone.

These ethanol blends can eventually separate, leaving water or a watery goo in the fuel tank, and carburetor. The compromised gasoline can be drawn into the carburetor and cause damage to the engine and/or create potential hazards.

If a fuel stabilizer is used, confirm that it is formulated to work with ethanol-gasoline blends.

- Clean all foreign material from the product. Store idle unit indoors in a dry, well-ventilated area that is inaccessible to children. Keep away from corrosive agents such as garden chemicals and deicing salts.
- Abide by all local regulations for the safe storage and handling of gasoline.

### When storing 1 month or shorter:

- Fuel stabilizer is an acceptable alternative in minimizing the formation of fuel gum deposits during storage. Add stabilizer to your fuel container (not the fuel tank on the auger). Run engine at least 3 minutes after adding stabilizer.

### When storing longer than a month:

- Drain all fuel from tank into a container approved for gasoline. Run engine until it stops.

# SPECIFICATIONS

## Earth Auger Specifications

Model ..... 201092  
 Auger Bit ..... 8 in. (20.3 cm)

### Overall Dimensions

Weight ..... 35 lbs. (16 kg)  
 Length ..... 48.4 in. (123 cm)  
 Width ..... 25.6 in. (65 cm)  
 Height ..... 10.6 in. (27 cm)

## Engine Specifications

Model ..... JF144FBV  
 Displacement ..... 53.5 cc  
 Type ..... 4-Stroke

### Spark Plug

OEM Type ..... A7TC  
 Replacement Type ..... A7RTC / CR7HSA  
 Gap ..... 0.023 - 0.031 in. (0.6 - 0.8 mm)

## Oil Specifications

DO NOT OVERFILL.

Type ..... \*See following chart  
 Capacity ..... 0.3 US qt. (240 mL)

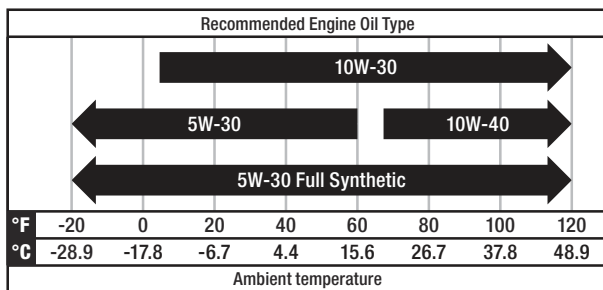

## Fuel Specifications

Use unleaded gasoline with a minimum octane rating of 87 and an ethanol content of 10% or less by volume. DO NOT USE E15 or E85. DO NOT OVERFILL.

Gasoline Capacity ..... 0.32 gal. (1.2 L)

## Temperature Specifications

Starting Temperature Range (°F/°C) ..... 5 to 104/-15 to 40

### NOTICE

**An important message about temperature:** Your product is designed and rated for continuous operation at ambient temperatures up to 104°F (40°C). When needed, it may be operated at temperatures ranging from 5°F (-15°C) to 122°F (50°C) for short periods of time. If exposed to temperatures outside this range during storage, it should be brought back within this range before operation. In any event, the product must always be operated outdoors, in a well-ventilated area and away from doors, windows and vents.

### NOTICE

Temperature will affect engine oil and engine performance. Change the type of engine oil used based on temperature shown in the "Recommended Engine Oil Type" table.

## TROUBLESHOOTING

Problem	Cause	Solution
Engine does not start.	The engine switch is in the "OFF" position	Move the engine switch to the "ON" position.
	Fuel strainer is clogged	Clean fuel strainer.
	Flooded engine	Let unit sit for 15 minutes or remove spark plug and clean per the instructions in the <i>Maintenance</i> section of this operator's manual.
	Spark plug gap is incorrect	Replace or adjust spark plug per the instructions in the <i>Maintenance</i> section in this operator's manual.
Engine will not accelerate, lacks power or stalls	Choke on	Ensure choke lever is in the "RUN" position.
	Air filter dirty	Clean air filter per the instructions in the <i>Maintenance</i> section of this operator's manual.
	Spark plug gap is incorrect	Replace or adjust spark plug per instructions in the <i>Maintenance</i> section of this operator's manual.
	Exhaust port/spark arrestor screen blocked	Clean exhaust port/spark arrestor screen per the instructions in the <i>Maintenance</i> section of this operator's manual.
Engine smokes excessively	Air filter dirty	Clean the air filter per the instructions in the <i>Maintenance</i> section of this operator's manual.
Auger bit turns while engine is idling	Idle speed is too high. Carburetor needs adjustment.	Call for free technical service at 1-877-338-0999

### For other issues and technical support:

Technical Support Team  
Toll Free 1-877-338-0999  
support@championpowerequipment.com

## WARRANTY\*

CHAMPION POWER EQUIPMENT  
2 YEAR LIMITED WARRANTY

### Warranty Qualifications

To register your product for warranty and FREE lifetime call center technical support please visit:

<https://www.championpowerequipment.com/register>

To complete registration you will need to include a copy of the purchase receipt as proof of original purchase. Proof of purchase is required for warranty service. Please register within ten (10) days from date of purchase.

### Repair/Replacement Warranty

CPE warrants to the original purchaser that the mechanical and electrical components will be free of defects in material and workmanship for a period of two years (parts and labor) from the original date of purchase and 180 days (parts and labor) for commercial and industrial use. Transportation charges on product submitted for repair or replacement under this warranty are the sole responsibility of the purchaser. This warranty only applies to the original purchaser and is not transferable.

### Do Not Return The Unit To The Place Of Purchase

Contact CPE's Technical Service and CPE will troubleshoot any issue via phone or e-mail. If the problem is not corrected by this method, CPE will, at its option, authorize evaluation, repair or replacement of the defective part or component at a CPE Service Center. CPE will provide you with a case number for warranty service. Please keep it for future reference. Repairs or replacements without prior authorization, or at an unauthorized repair facility, will not be covered by this warranty.

### Warranty Exclusions

This warranty does not cover the following:

#### Normal Wear

Products with mechanical and electrical components need periodic parts and service to perform well. This warranty does not cover repair when normal use has exhausted the life of a part or the equipment as a whole.

#### Installation, Use and Maintenance

This warranty will not apply to parts and/or labor if the product is deemed to have been misused, neglected, involved in an accident, abused, loaded beyond the product's limits or modified. Normal maintenance is not covered by this warranty and is not required to be performed at a facility or by a person authorized by CPE.

### Other Exclusions

This warranty excludes:

- Cosmetic defects such as paint, decals, etc.
- Wear items such as starter pulleys, starter ropes, filter elements, auger bits, earth blades, and fishtail blades.
- Failures due to acts of God and other force majeure events beyond the manufacturer's control.
- Problems caused by parts that are not original Champion Power Equipment parts.

### Limits of Implied Warranty and Consequential Damage

Champion Power Equipment disclaims any obligation to cover any loss of time, use of this product, freight, or any incidental or consequential claim by anyone from using this product. THIS WARRANTY AND THE ATTACHED U.S. EPA and/or CARB EMISSION CONTROL SYSTEM WARRANTIES (WHEN APPLICABLE) ARE IN LIEU OF ALL OTHER WARRANTIES, EXPRESS OR IMPLIED, INCLUDING WARRANTIES OF MERCHANTABILITY OR FITNESS FOR A PARTICULAR PURPOSE.

A unit provided as an exchange will be subject to the warranty of the original unit. The length of the warranty governing the exchanged unit will remain calculated by reference to the purchase date of the original unit.

This warranty gives you certain legal rights which may change from state to state or province to province. Your state or province may also have other rights you may be entitled to that are not listed within this warranty.

### Contact Information

#### Address

Champion Power Equipment, Inc.  
6370 S Pioneer Way, Unit 101  
Las Vegas, NV 89113 USA  
[www.championpowerequipment.com](http://www.championpowerequipment.com)

#### Customer Service

Toll Free: 1-877-338-0999  
[info@championpowerequipment.com](mailto:info@championpowerequipment.com)  
Fax no.: 1-562-236-9429

#### Technical Service

Toll Free: 1-877-338-0999  
[tech@championpowerequipment.com](mailto:tech@championpowerequipment.com)

📞 EMERGENCY 24 HOUR SUPPORT: 1-562-204-1188

\*Except as otherwise stipulated in any of the following enclosed Emission Control System Warranties (when applicable) for the Emission Control System: U.S. Environment Protection Agency (EPA) and/or California Air Resources Board (CARB).

**CHAMPION POWER EQUIPMENT, INC. (CPE),  
THE UNITED STATES ENVIRONMENTAL PROTECTION AGENCY (U.S. EPA)  
EMISSION CONTROL SYSTEM WARRANTY**

**Your Champion Power Equipment (CPE) engine complies with U.S. EPA emissions regulations.**

**YOUR WARRANTY RIGHTS AND OBLIGATIONS:**

The U.S. EPA and Champion Power Equipment (CPE) are pleased to explain the Federal Emission Control System's Warranty on your 2026 small off-road engine and engine powered equipment. In the United States new equipment that use small off-road engines shall be designed, built and equipped to meet U.S. EPA regulations.

CPE shall warrant the emission control system on your small off-road engine and equipment for the period of listed below, provided there has been no abuse, neglect, unapproved modification or improper maintenance of your equipment.

Your emission control system may include parts such as: carburetor, fuel tanks, fuel lines (for liquid fuel and fuel vapors), fuel caps, valves, canisters, filters, clamps, connectors, and other emission related assemblies. Where a warrantable condition exists, CPE will repair your small off-road engine at no cost to you including diagnosis, parts and labor.

**MANUFACTURER'S WARRANTY COVERAGE:**

This emission control system is warranted for two years, subject to provisions set forth below. If, during the warranty period, an emission related part on your engine is defective in materials or workmanship, the part will be repaired or replaced by CPE.

**OWNER'S WARRANTY RESPONSIBILITIES:**

As the small off-road engine owner, you are responsible for the performance of the required maintenance listed in your Owner's Manual. CPE recommends that you retain all your receipts covering maintenance on your small off-road engine, but CPE cannot deny warranty solely for the lack of receipts or for your failure to ensure the performance of all scheduled maintenance.

As the small off-road engine owner, you should be aware that CPE may deny you warranty coverage if your small off-road engine or a part has failed due to abuse, neglect, or improper maintenance or unapproved modifications.

You are responsible for presenting your small off-road engine to an Authorized CPE service outlet, distribution center or alternate service outlet as described in (3)(f.) below, CPE dealer or CPE, Las Vegas, NV. as soon as a problem exists. The warranty repairs should be completed in a reasonable amount of time, not to exceed 30 days.

If you have any questions regarding your warranty coverage, you should contact:

Champion Power Equipment, Inc.  
Customer Service  
6370 S Pioneer Way, Unit 101  
Las Vegas, NV 89113  
1-877-338-0999  
tech@championpowerequipment.com

## **EMISSION CONTROL SYSTEM WARRANTY**

The following are specific provisions relative to your Emission Control System (ECS) Warranty Coverage.

- 1. APPLICABILITY:** This warranty shall apply to 1997 and later model year small off-road engines. The warranty period begins on the date the new engine or equipment is delivered to an ultimate purchaser and shall continue for 24 consecutive months thereafter.
- 2. GENERAL EMISSIONS WARRANTY COVERAGE**

CPE warrants to the ultimate purchaser of the new engine or equipment and to each subsequent owner that the ECS when installed is:

  - 2a. Designed, built and equipped to conform to U.S. EPA emissions standards for spark-ignited engines at or below 19 kilowatts;
  - 2b. Free from defects in materials and workmanship that cause the failure of a warranted part to be identical in all material respects to the part as described in the engine manufacturer's application for certification for a period of two years.
- 3. THE WARRANTY ON EXHAUST AND EVAPORATIVE EMISSION-RELATED PARTS WILL BE INTERPRETED AS FOLLOWS:**
  - 3a. Any warranted part that is not scheduled for replacement as required maintenance in the Operators Manual required by subsection (e) must be warranted for the warranty period defined in subsection (b)(2). If any such part fails during the period of warranty coverage, it must be repaired or replaced by CPE according to subsection (3)(3d) below. Any such part repaired or replaced under the warranty must be warranted for a time not less than the any remaining warranty period.
  - 3b. Any warranted emissions-related part that is scheduled only for regular inspection in the Operators Manual shall be warranted for the warranty period defined in subsection (b)(2). A statement in such written instructions to the effect of "repair or replace as necessary" shall advise owners of the warranty coverage for emissions related parts. Replacement within the warranty period is covered by the warranty and will not reduce the period of warranty coverage. Any such emission-related part repaired replaced under warranty shall be warranted for a time not less than the remaining warranty period.
  - 3c. Any warranted emissions-related part that is scheduled for replacement as required maintenance in the Operators Manual shall be warranted for the period of time prior to the first scheduled replacement point for that part. If the part fails prior to the first scheduled replacement, the part shall be repaired or replaced by CPE according to Subsection (3)(3d) below. Any such emissions-related part repaired or replaced under warranty shall be warranted for a time not less than the remainder of the period prior to the first scheduled replacement point for such emissions-related part.
  - 3d. Repair or replacement of any warranted emissions-related part under the Warranty provisions of this article shall be performed at no charge to the owner at a CPE Authorized Service Outlet.
  - 3e. The owner of the small off-road engine shall not be charged for diagnostic labor that leads to the determination that a warranted part is in fact defective, provided that such diagnostic work is performed at a CPE Authorized Service Outlet.
  - 3f. CPE shall pay for covered emissions warranty repairs at non-authorized service outlets under the following circumstances:
    - i. The service is required in a population center with a population over 100,000 according to U.S. Census 2000 without a CPE Authorized Service Outlet AND
    - ii. The service is required more than 100 miles from a CPE Authorized Service Outlet. The 100-mile limitation does not apply in the following states: Alaska, Arizona, Colorado, Hawaii, Idaho, Montana, Nebraska, Nevada, New Mexico, Oregon, Texas, Utah and Wyoming.
  - 3g. CPE shall be liable for damages to other original engine components or approved modifications proximately caused by a failure under warranty of an emission-related part covered by the ECS Warranty.
  - 3h. Throughout the ECS Warranty period, CPE shall maintain a supply of warranted emission-related parts sufficient to meet the expected demand for such emission-related parts.
  - 3i. Any CPE Authorized, and approved emission-related replacement part may be used in the performance of any ECS Warranty maintenance or repair and will be provided without charge to the owner. Such use shall not reduce CPE's warranty obligation.
  - 3j. Unapproved add-on or modified parts may not be used to modify or repair a CPE engine. Such use voids this Warranty and shall be grounds for disallowing a warranty claim. CPE shall not be liable hereunder for failures of any warranted parts of a CPE engine caused by the use of such an unapproved add-on or modified part.

**EMISSION-RELATED PARTS INCLUDE THE FOLLOWING: (using those portions of the list applicable to the engine)**

<b>Systems covered by this warranty</b>	<b>Parts Description</b>
Fuel Metering System	Fuel regulator, Carburetor and internal parts
Air Induction System	Air cleaner, Intake manifold
Ignition System	Spark plug and parts, Magneto ignition system
Exhaust System	Exhaust manifold, catalytic converter
Miscellaneous Parts	Tubing, Fittings, Seals, Gaskets, and Clamps associated with these listed systems.
Evaporative Emissions	Fuel Tank, Fuel Cap, Fuel Lines (for liquid fuel and fuel vapors), Fuel Line Fittings, Clamps, Pressure Relief Valves, Control Valves, Control Solenoids, Electronic Controls, Vacuum Control Diaphragms, Control Cables, Control Linkages, Purge Valves, Gaskets, Liquid/Vapor Separator, Carbon Canister, Canister Mounting Brackets, Carburetor Purge Port Connector

**TO OBTAIN WARRANTY SERVICE:**

You must take your CPE engine or the product on which it is installed, along with your warranty registration card or other proof of original purchase date, at your expense, to any Champion Power Equipment dealer who is authorized by Champion Power Equipment, Inc. to sell and service that CPE product during normal business hours. Alternate service locations defined in Section (3)(f.) above must be approved by CPE prior to service. Claims for repair or adjustment found to be caused solely by defects in material or workmanship will not be denied because the engine was not properly maintained and used.

**If you have any questions regarding your warranty rights and responsibilities, or to obtain warranty service, please write or call Customer Service at Champion Power Equipment, Inc.**

**Champion Power Equipment, Inc.**  
6370 S Pioneer Way, Unit 101  
Las Vegas, NV 89113  
1-877-338-0999  
Attn.: Customer Service  
tech@championpowerequipment.com