



OPERATOR'S MANUAL

MODEL #201495
8.8 CU. FT., 79 CC CONCRETE MIXER



ACTIVATE YOUR WARRANTY

by registering your product:
championpowerequipment.com

SERIAL NO.



 **1-877-338-0999**

or visit championpowerequipment.com

SAVE THESE INSTRUCTIONS. This manual contains important safety precautions which should be read and understood before operating the product. Failure to do so could result in serious injury. This manual should remain with the product.

Specifications, descriptions and illustrations in this manual are as accurate as known at the time of publication, but are subject to change without notice.

TABLE OF CONTENTS	
Introduction	3
Safety Definitions	3
Important Safety Instructions	4
Fuel Safety	5
Safety and Dataplate Labels	7
Safety Symbols	9
Operation Symbols	11
Quick Start Label Symbols	11
Controls and Features	12
Concrete Mixer	12
Engine	13
Accessories	14
Tools Needed	14
Parts Included	15
Assembly	16
Unpacking	16
Assemble the Wheel Bracket to the U-Frame	16
Assemble the Support Leg to the U-Frame	16
Assemble the Wheels	16
Assemble the Bottom Drum Half to the U-Frame	17
Assemble the Drum Tipping Wheel	17
Assemble the Drum Tipping Wheel Lock Bar and Foot Lever	17
Assemble the Top Half of the Drum to the Bottom Half of the Drum	18
Assemble the Mixing Blades to the Drum	18
Assemble the Engine	19
Add Engine Oil	20
Add Fuel	21
Operation	22
Before Each Use Inspect the Mixer	22
Tipping Wheel	22
Loading and Mixing Positions	23
Starting the Engine	23
Stopping the Engine	24
Under Normal Conditions	24
Loading the Mixer	24
Maintenance	24
Cleaning the Mixer	25
Check Hardware	25
Changing the Engine Oil	25
Cleaning and Adjusting the Spark Plug(s)	25
Cleaning the Air Filter	26
Maintenance Schedule	26
Storage	26
Concrete Mixer Storage	27
Engine Stored for Less than 30 Days	27
Engines Stored for Over 30 Days	27
Specifications	28
Concrete Mixer Specifications	28
Engine Specifications	28
Engine Oil Specifications	28
Fuel Specifications	28
Spark Plug Specifications	28
Valve Specifications	28
Regulatory Compliance	28
Troubleshooting	29

 **FOR PARTS BREAKDOWN**

Search by model number at
championpowerequipment.com

INTRODUCTION

Congratulations on your purchase of a Champion Power Equipment (CPE) product. CPE designs, builds, and supports all of our products to strict specifications and guidelines. With proper product knowledge, safe use, and regular maintenance, this product should bring years of satisfying service.

Every effort has been made to ensure the accuracy and completeness of the information in this manual at the time of publication, and we reserve the right to change, alter and/or improve the product and this document at any time without prior notice.

CPE highly values how our products are designed, manufactured, operated, and serviced as well as providing safety to the operator and those around the product. Therefore, it is **IMPORTANT** to review this product manual and other product materials thoroughly and be fully aware and knowledgeable of the assembly, operation, dangers and maintenance of the product before use. Fully familiarize yourself, and make sure others who plan on operating the product fully familiarize themselves too, with the proper safety and operation procedures before each use. Please always exercise common sense and always err on the side of caution when operating the product to ensure no accident, property damage, or injury occurs. We want you to continue to use and be satisfied with your CPE product for years to come.

When contacting CPE about parts and/or service, you will need to supply the complete model and serial numbers of your product. Transcribe the information found on your product's nameplate label to the table below

CPE TECHNICAL SUPPORT TEAM
1-877-338-0999
MODEL NUMBER
201495
SERIAL NUMBER
DATE OF PURCHASE
PURCHASE LOCATION

SAFETY DEFINITIONS

The purpose of safety symbols is to attract your attention to possible dangers. The safety symbols, and their explanations, deserve your careful attention and understanding. The safety warnings do not by themselves eliminate any danger. The instructions or warnings they give are not substitutes for proper accident prevention measures.

DANGER

DANGER indicates a hazardous situation which, if not avoided, will result in death or serious injury.

WARNING

WARNING indicates a hazardous situation which, if not avoided, could result in death or serious injury.

CAUTION

CAUTION indicates a hazardous situation which, if not avoided, could result in minor or moderate injury.

NOTICE

NOTICE indicates information considered important, but not hazard-related (e.g., messages relating to property damage).

IMPORTANT SAFETY INSTRUCTIONS

⚠ WARNING

Cancer and Reproductive Harm – www.P65Warnings.ca.gov

⚠ DANGER

Concrete mixer exhaust contains carbon monoxide, a colorless, odorless, poisonous gas. Breathing carbon monoxide will cause nausea, dizziness, fainting or death. If you start to feel dizzy or weak, get to fresh air immediately.

OPERATE THE CONCRETE MIXER OUTDOORS ONLY IN A WELL VENTILATED AREA AND POINT EXHAUST AWAY FROM ANY BUILDING OR OTHER CONFINED STRUCTURES.

NEVER operate the concrete mixer inside any building, including garages, basements, sheds or other confined spaces.

DO NOT allow exhaust fumes to enter a confined area through windows, doors, vents or other openings while operating the concrete mixer.

⚠ DANGER

Using an engine indoors **CAN KILL YOU IN MINUTES**. Engine exhaust contains carbon monoxide. This is a poison you cannot see or smell.

NEVER use inside a building, garage or any enclosed structure, **EVEN IF** doors and windows are open.

ALWAYS use **OUTSIDE** and far away from windows, doors, and vents.

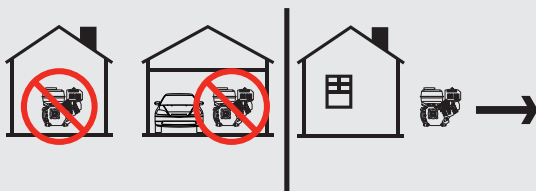

⚠ WARNING

DO NOT allow untrained individuals or children to use this unit.

⚠ DANGER

Rotating parts can entangle hands, feet, hair, clothing and/or accessories. Traumatic amputation or severe laceration can result.

Keep hands and feet away from rotating parts.

Tie up long hair and remove jewelry.

Operate equipment with guards in place.

DO NOT wear loose-fitting clothing, dangling drawstrings or items that could become caught.

⚠ WARNING

Before operating your machine, carefully read and understand all safety, controls and operating instructions in this Operator's Manual.

Failure to follow these instructions can result in serious personal injury.

⚠ WARNING

- Always clear the work area before each use. Remove all objects such as rocks, broken glass, nails, wire, or string which can be thrown or become entangled in the machine.
- ALWAYS operate on level surfaces.
- Always wear eye protection with side shields marked to comply with ANSI Z87.1. Failure to do so could result in objects being thrown into your eyes and other possible serious injuries.
- Always keep all bystanders, children, and pets at least 10 ft. (3m) away when operating the concrete mixer.
- Always wear sound protection (ear muffs or ear plugs) to reduce the risk of hearing loss associated with long term engine sound level(s).
- Always wear heavy long pants, boots, gloves, and a long-sleeve shirt. Do not wear loose clothing, jewelry, short pants, sandals, or go barefoot. Secure long hair so it is above shoulder level to prevent entanglement in rotating parts.
- Do not operate this unit when you are tired, ill, or under the influence of alcohol, drugs, or medication.
- Do not operate in poor lighting.
- Always wear a face filter mask in dusty conditions to reduce the risk of injury associated with the inhalation of dust and cement powder.
- Always keep firm footing and balance when operating and loading the mixer drum.
- Do not overreach. Overreaching can result in loss of balance or exposure to hot contact surfaces or rotating parts.

⚠ WARNING

- Always inspect the unit before each use for loose fasteners, fuel leaks, etc. Replace damaged parts.
- Use only identical manufacturer's replacement parts and accessories. Use of any other replacement parts may create a hazard or cause product damage and void your warranty.
- Maintain the equipment per maintenance instructions located in this Operator's Manual.

⚠ DANGER

Rotating parts can cause severe bodily injury. Stop the engine and ensure all parts have stopped rotating before installing/ changing parts or performing maintenance.

⚠ WARNING

Sparks can result in fire or electrical shock.

When servicing the engine:

Disconnect the spark plug wire and place it where it cannot contact the plug.

DO NOT check for spark with the plug removed.

Use only approved spark plug testers.

⚠ WARNING

Running engines produce heat. Severe burns can occur on contact. Combustible material can catch fire on contact.

DO NOT touch hot surfaces.

Avoid contact with hot exhaust gases.

Allow equipment to cool before touching.

Maintain at least 3 ft. (91.4 cm) of clearance on all sides to ensure adequate cooling and safe operation during use.

Maintain at least 5 ft. (1.5 m) of clearance from combustible materials.

⚠ WARNING

Rapid retraction of the starter cord will pull hand and arm towards the engine faster than you can let go. Broken bones, fractures, bruises or sprains could result.

Unintentional startup can result in entanglement, traumatic amputation or laceration.

When starting engine, pull the starter cord slowly until resistance is felt and then pull rapidly to avoid kickback.

Fuel Safety**⚠ DANGER**

GASOLINE AND GASOLINE VAPORS ARE HIGHLY FLAMMABLE AND EXPLOSIVE.

Fire or explosion can cause severe burns or death.

Gasoline and gasoline vapors:

- Gasoline vapors are highly flammable and explosive.
- Gasoline vapors can cause a fire or explosion if ignited.
- Gasoline is a liquid fuel and the resulting gasoline vapors can ignite and cause a fire or explosion.
- Gasoline is a skin irritant and needs to be cleaned up immediately if spilled on skin or clothes.

- Gasoline has a distinctive odor, this will help detect potential leaks quickly.
- In any petroleum gas fire, flames should not be extinguished unless by doing so the fuel supply valve can be turned OFF. This is because if a fire is extinguished and a supply of fuel is not turned OFF, then an explosion hazard could be created.
- Gasoline vapors expand and contract with ambient temperatures. Never fill the gasoline tank past the red FULL indicator on the fuel filter, as gasoline vapors need room to expand if temperatures rise.

⚠ WARNING

When adding or removing gasoline:

Do not light or smoke cigarettes.

Always stop the engine and allow to cool for a minimum of two minutes before refueling.

Always loosen gasoline cap slowly to release vapor pressure and to keep fuel from escaping around the gasoline cap.

Always replace and tighten the gasoline cap securely after fueling.

Never remove the gasoline cap or add gasoline while the engine is running or when the engine is hot.

Always fill or drain gasoline outdoors in a well-ventilated area.

Do not pump gasoline directly into the concrete mixer at the gas station.

Always store gasoline in an EPA compliant container or to transfer the gasoline to the concrete mixer.

Do not overfill the gasoline tank.

Always keep gasoline away from sparks, open flames, pilot lights, heat and other sources of ignition.

⚠ WARNING

When starting the concrete mixer:

Do not attempt to start a damaged concrete mixer.

Always check that the gasoline cap, air filter, spark plug, fuel lines and exhaust system are properly in place.

Always allow spilled gasoline to evaporate fully before attempting to start the engine.

Always be certain that the concrete mixer is resting firmly on level ground.

⚠ WARNING

When operating the concrete mixer:

Do not move or tip the concrete mixer during operation.

⚠ WARNING

When transporting or servicing the concrete mixer:

Always check that the fuel valve is in the OFF position and the gasoline tank is empty.

Disconnect the spark plug wire.

⚠ WARNING

When storing the concrete mixer:

Always store away from sparks, open flames, pilot lights, heat and other sources of ignition.

Never store the concrete mixer or gasoline near furnaces, water heaters, or any other appliances that produce heat or have automatic ignitions.

⚠ WARNING

Never use a gasoline container, gasoline tank, or any other fuel item that is broken, cut, torn or damaged.



Safety and Dataplate Labels

These labels warn you of potential hazards that can cause serious injury. Read them carefully.

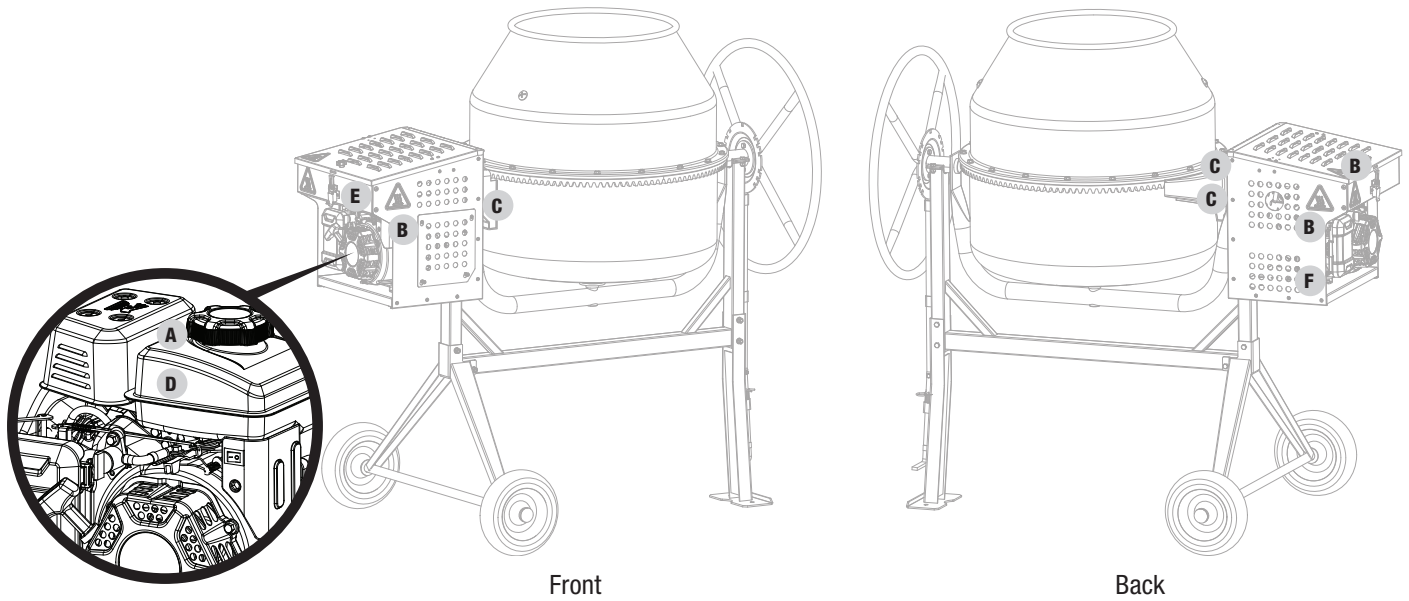
If a label comes off or becomes hard to read, contact Technical Support Team for possible replacement.











	LABEL	DESCRIPTION
A		Hot Surface Engine
B		Hot Surface Unit
C		Pinch Point
D		Safety Icons Engine

LABEL	DESCRIPTION
<p>E</p> 	<p>Safety Icons Unit</p>
<p>F</p> 	<p>Dataplate</p>

Safety Symbols

Some of the following symbols may be used on this product. Please study them and learn their meaning. Proper interpretation of these symbols will allow you to more safely operate the product.

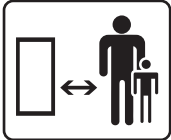
SYMBOL	MEANING
	Read Operator's Manual. To reduce the risk of injury, user must read and understand operator's manual before using this product.
	Eye and Ear Protection. Always wear safety goggles or safety glasses with side shields, and as necessary a full face-shield as well as full ear protection when operating this product.
	Footwear. Always wear safety shoes or heavy boots when operating the machine.
	Gloves. Always wear nonslip, heavy-duty protective gloves when operating this product.
	Safety Alert. This machine was built to be operated according to the safe operation practices in this manual. As with any type of power equipment, carelessness or error on the part of the operator can result in serious injury. This machine is capable of amputating fingers, hands, toes and feet and throwing foreign objects. Failure to observe the safety instructions could result in serious injury or death.
	Risk of Fire. Fuel and its vapors are extremely flammable and explosive. Fire can cause severe burns or death. Do not add fuel while the product is operating or still hot.
	Hot Surface. To reduce the risk of injury or damage, avoid contact with any hot surface.
	Open Flame Alert. Fuel and its vapors are extremely flammable and explosive. Keep fuel away from smoking, open flames, sparks, pilot lights, heat, and other ignition sources.

SYMBOL	MEANING
	<p>Toxic Fumes. The engine exhaust from this product contains chemicals known to the state of California to cause cancer and birth defects and other reproductive harm.</p> <p>Risk of Asphyxiation. This engine emits carbon monoxide, an odorless, colorless poison gas. Breathing carbon monoxide can cause nausea, fainting or death. Always use in a well ventilated area.</p>
	<p>Clearance. Keep all objects including others at least 10 feet (3m) from this machine. Only one person should operate the concrete mixer.</p>
	<p>Risk of loose clothing, long hair and body parts being drawn into the spinning drum or drive gear.</p>

Operation Symbols

Some of the following symbols may be used on this product. Please study them and learn their meaning. Proper interpretation of these symbols will allow you to more safely operate the product.

SYMBOL	MEANING
	STOP or OFF
	Choke
	Run
	Fuel Valve ON/OFF

SYMBOL	MEANING
	Throttle Lever FAST: forward position
	Throttle Lever SLOW: rear position

Quick Start Label Symbols

Some of the following symbols may be used on this product. Please study them and learn their meaning. Proper interpretation of these symbols will allow you to more safely operate the product.

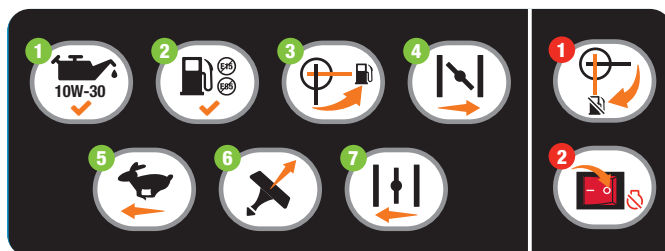

Starting the Engine

⚠ DANGER

Move concrete mixer outside and far away from windows, doors and intake ventilation covers.

1. **Check oil level.**
Recommended oil is 10W-30.
2. **Check gasoline level.**
When adding gasoline, use a minimum octane rating of 87 and an ethanol content of 10% or less by volume.
3. Turn the **fuel valve** to “ON” position.
4. Move **choke lever** to “CHOKE” position.
5. Move the **throttle lever** to the left for the full throttle position.
6. Pull the **recoil cord**.
7. Move the **choke lever** to “RUN” position.

Stopping the Engine

1. Turn the **fuel valve** to “OFF” position.
2. Press **engine switch** to the “OFF” position.

CONTROLS AND FEATURES

Read this operator's manual before operating your concrete mixer. Familiarize yourself with the location and function of the controls and features. Save this manual for future reference.

Concrete Mixer

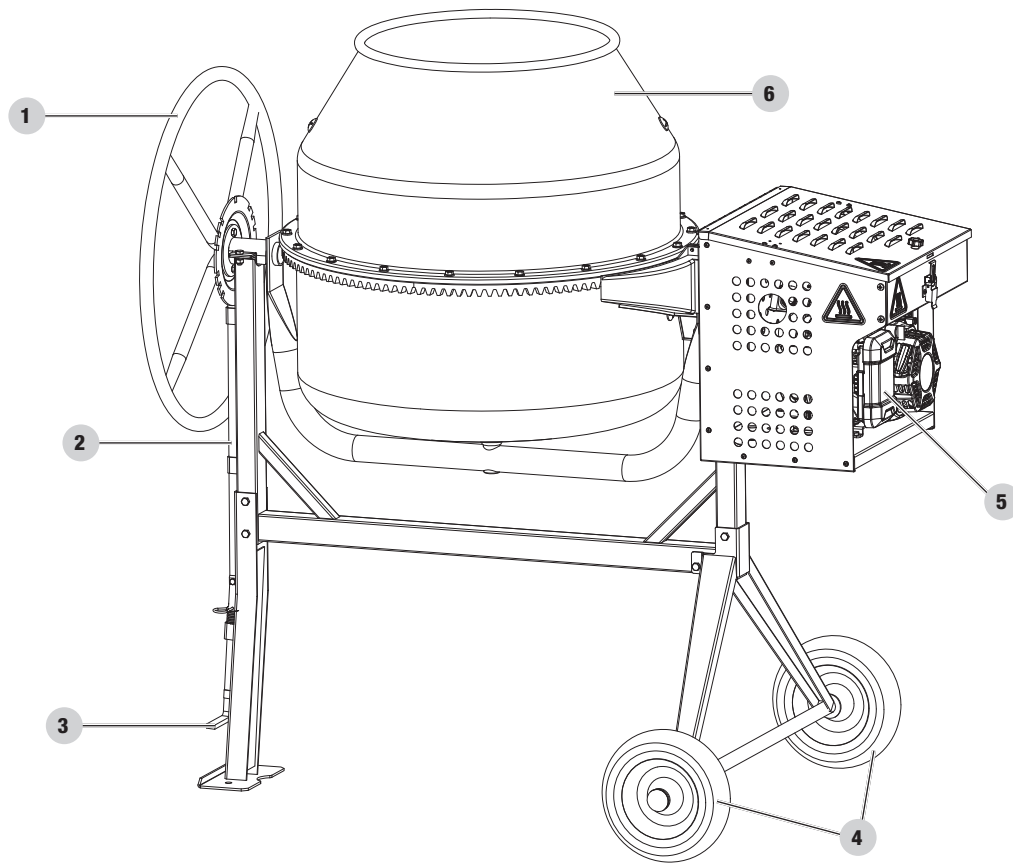

1. Tipping Wheel
2. Tipping Wheel Lock Bar
3. Foot Lever
4. Wheels
5. Engine
6. Drum

Engine

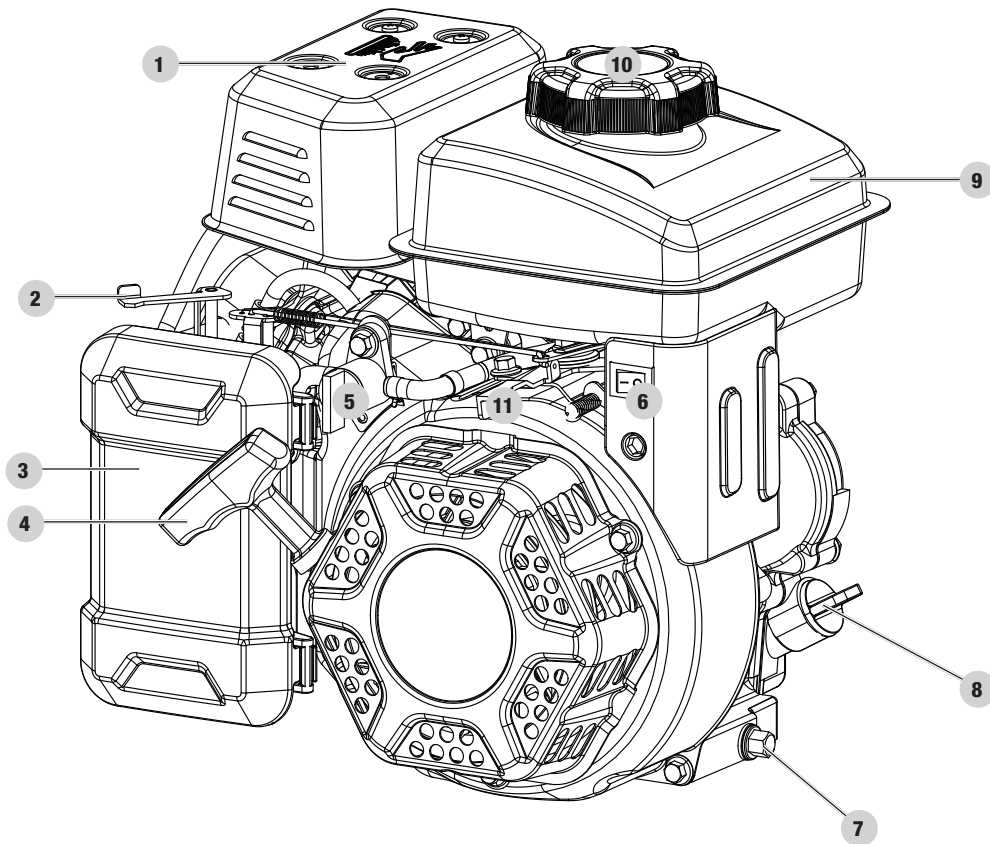

- | | |
|--------------------------|---|
| 1. Muffler | 6. Engine On / Off Switch |
| 2. Choke | 7. Oil Drain Bolt (on each side) |
| 3. Air Filter | 8. Engine Oil Fill Cap / Dipstick (on each side) |
| 4. Recoil Starter | 9. Gasoline Tank – 0.3 gal. (1.29 L) |
| 5. Fuel Valve | 10. Gasoline Tank Cap |
| | 11. Throttle Control |

Accessories



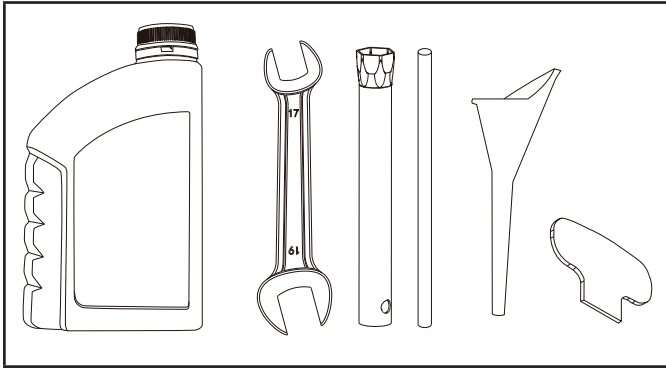

Engine Oil [10W-30: 13.5 fl. oz. (400 ml)]	1
Engine Oil Funnel	1
Spark Plug Wrench	1
17 x 19mm Open End Wrench	1
Butterfly Wrench	1

Tools Needed

- Metric Wrench and Socket Set
- Rubber Mallet
- Phillips Head Screwdriver

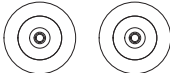
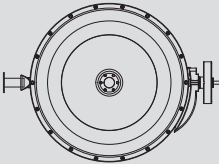
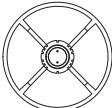

Parts Included

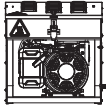
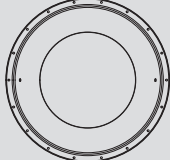
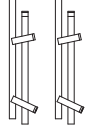
Part	Part Qty.	Part Reference	Hardware Needed	Hardware Qty.	Tool Needed	Torque (N.m)
Wheel Bracket	1		Bolt M8 × 70	2	1× 14mm wrench or socket	7.8
			Nut M8	2	1× 14mm wrench	
			Lock Washer Ø8	2		
			Flat Washer Ø8	2		
Support Leg	1		Bolt M8 × 70	2	1× 14mm wrench or socket	7.8
			Nut M8	2	1× 14mm wrench	
			Lock Washer Ø8	2		
			Flat Washer Ø8	2		
Wheels	1		Wheel Cap	2	Rubber Mallet	
Bottom Drum Half	1		Bolt M8 × 70	1	1× 14mm wrench or socket	7.8
			Bolt M8 × 20	2	1× 14mm wrench or socket	7.8
			Nut M8	3	1× 14mm wrench	
			Lock Washer Ø8	3		
			Flat Washer Ø8	3		
Tipping Wheel	1		Bolt M8 × 20	2	1× 14mm wrench or socket	7.8
			Nut M8	2	1× 14mm wrench	
			Lock Washer Ø8	2		
			Flat Washer Ø8	2		
Tipping Wheel Lock Bar & Foot Lever	1		Spring 2 × 22 × 36 × 7.5mm	1		
			Bolt M6 × 25	1	1× 10mm wrench or socket	2.8
			Nut M6	1	1× 10mm wrench or socket	
			R clip	1		
Engine	1		Bolt M8 × 70	1	1× 14mm wrench or socket	7.8
			Nut M8	3	1× 14mm wrench	
			Lock Washer Ø8	3		
			Flat Washer Ø8	3		
			Engine Mount Foam	1		
Top Drum Half	1		Bolt M8 × 16	6	1× 12mm wrench or socket	7.8
			Nut M8	12	1× 12mm wrench	
Mixing Blades	2		Bolt M12 × 25	4	Butterfly Wrench (included)	
			Nut M12	4	1× 19mm wrench (included)	24
			Lock Washer Ø12	4		
			Butterfly Wrench	1		

ASSEMBLY

NOTICE

This assembly requires 2 people.

If your concrete mixer is already assembled, skip this section and move to the *Add Engine Oil* section.

If unassembled, please read and follow these instructions.

This concrete mixer includes many large and heavy parts. The assembly requires 2 people.

If you have any questions regarding the assembly of your concrete mixer, call our Technical Support Team at 1-877-338-0999. Please have your serial number and model number available.

Unpacking

1. Set the package on a solid flat surface.
2. Carefully cut and remove any shipping bands and remove the lid from the package.
3. Remove all parts and hardware before beginning assembly.

NOTICE

The assembly hardware is organized by assembly step to assist in the assembly of the mixer.

Assemble the Wheel Bracket to the U-Frame

1. Insert the U-frame (A) into the slot on the wheel bracket (B) as shown and align the bolt holes.
2. Insert two (2) M8 x 70 bolts through the holes on the wheel bracket and U-frame.
3. Place a flat washer and lock washer on each bolt, then thread a M8 nut onto each bolt and hand tighten.
4. Using a 14mm socket and wrench, securely tighten each set of nuts and bolts.

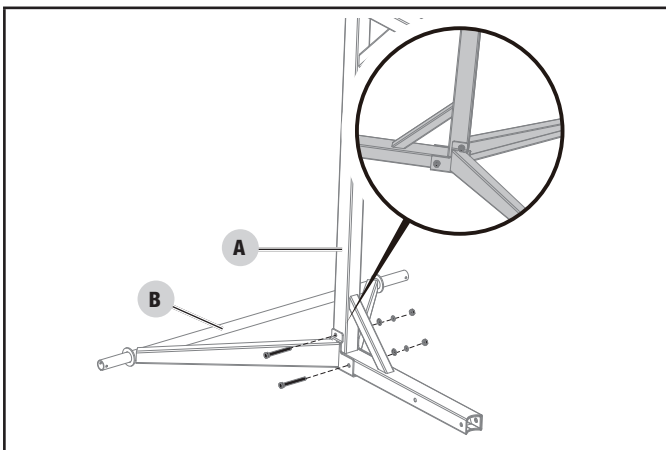

Assemble the Support Leg to the U-Frame

1. With the assembly resting on the wheel bracket and U-frame as shown, slide the support leg (C) over the corner of the U-frame (A) and align the bolt holes.
2. Insert two (2) M8 x 70 bolts through the holes on the support leg (C) and the U-frame (A).
3. Place a flat washer and lock washer on each bolt, then thread a M8 nut onto each bolt and hand tighten.
4. Using a 14mm socket and wrench, securely tighten each set of nuts and bolts.

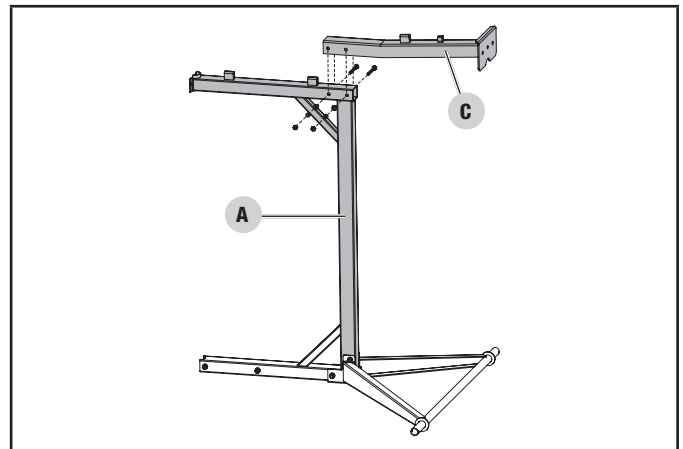

Assemble the Wheels

1. Flip the assembly up to stand on the wheel bracket (B) and the support leg (C) as shown.
2. Lift one side of the wheel bracket and slide a wheel onto the axle. Repeat this step for the other side.
3. Ensuring that the wheel is completely seated on the axle, using a rubber mallet, lightly tap a wheel cap on the axle. Ensure that the wheel cap is securely seated, and the wheel does not move outward. Repeat these steps for the other wheel.

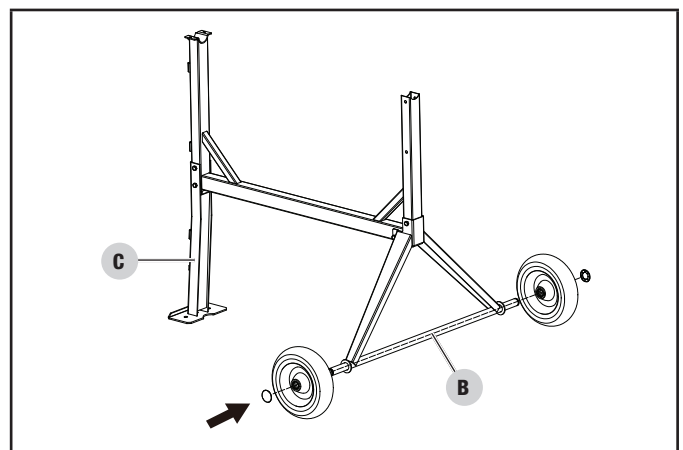

Assemble the Bottom Drum Half to the U-Frame

NOTICE

This assembly requires 2 people.

1. With the assembly resting on the wheels and front support leg, using 2 people, lift the bottom drum half (D) up over the U-frame (A).
2. Align the square tube (1), below the engine shaft with the hole in the frame (2) while also aligning the round tube (3) with the U-bracket (4) on the opposite side, then gently lower the bottom drum half into place.
3. Insert a M8 x 70 bolt through the holes on the frame tube (2) and the bottom drum half tube (1).
4. Place a flat washer and lock washer onto the bolt, then thread a M8 nut onto the bolt and hand tighten.
5. Using a 14mm socket and wrench, securely tighten bolt and nut.
6. On the opposite side, place the upper U-bracket (5) over the round tube (3) aligning the bolt holes.
7. Insert two (2) M8 x 20 bolts down through the holes on the upper U-bracket (5) and the lower U-bracket (4).
8. Place a flat washer and lock washer onto each bolt, then thread a M8 nut onto each bolt and hand tighten.
9. Using a 13mm and 14mm wrench, securely tighten each set of nuts and bolts.

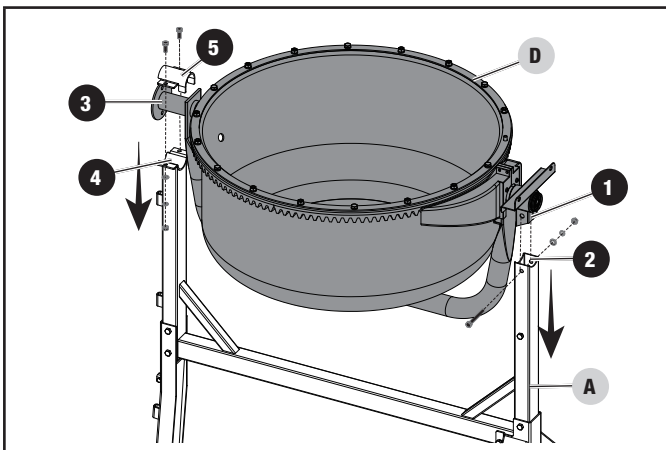

Assemble the Drum Tipping Wheel

NOTICE

This assembly requires 2 people.

1. From the support leg side, insert a M8 x 20 hex bolt through each hole on the mounting bracket (1). You will need to tip the drum to one side to get the lower bolt through the hole.
2. Align the holes in the tipping wheel (2) with the bolts that were inserted in step 1 and place the tipping wheel on the bolts.
3. Place a flat washer and lock washer on each bolt, then thread a M8 nut onto each bolt and hand tighten.
4. Using a 13mm and 14mm wrench, securely tighten each set of nuts and bolts. You will need to tip the drum to one side to access the lower bolt with the 14mm socket and wrench.

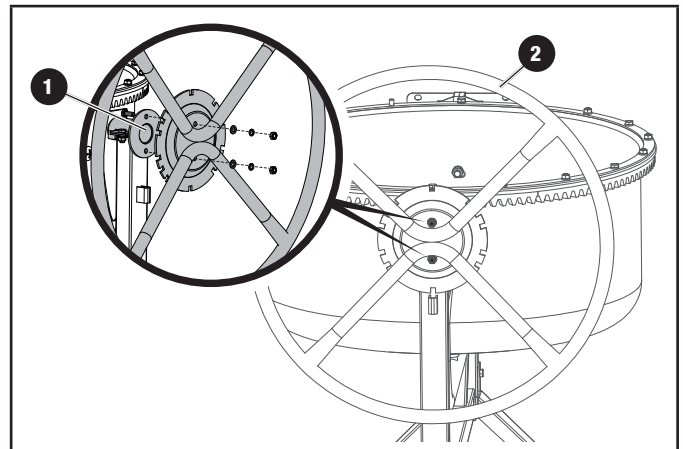

Assemble the Drum Tipping Wheel Lock Bar and Foot Lever

NOTICE

This assembly requires 2 people.

1. With the assembly standing on the wheels and front support leg, insert the lock bar (1) up through the middle hole (2) on the front support leg and the top hole (3) on the U-frame.
2. Insert the L-shaped foot lever (4) up through the bottom hole (5) with the L portion pointed to either the right or left side, depending on the preference of which foot you prefer to use to actuate the lever during use of the mixer.
3. Slide the spring (6) over the top of the L-shaped foot lever (4).
4. Align the holes on the lock bar (1) with the hole on the foot lever (4) and insert the M6 x 25 bolt through the holes, then thread the M6 lock nut onto the bolt and hand tighten.

- Using a 10mm socket and wrench, securely tighten the lock nut and bolt.
- Pull the spring (6) back slightly and insert the R-clip (7) through the hole on the L-shaped foot lever (4) to lock the spring in place.

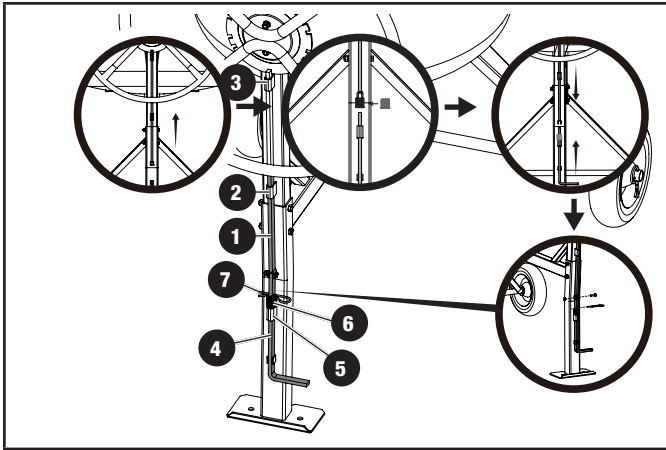

Assemble the Top Half of the Drum to the Bottom Half of the Drum

NOTICE

This assembly requires 2 people.

- Using the foot lever, release the drum lock and tip the drum so it faces skyward.

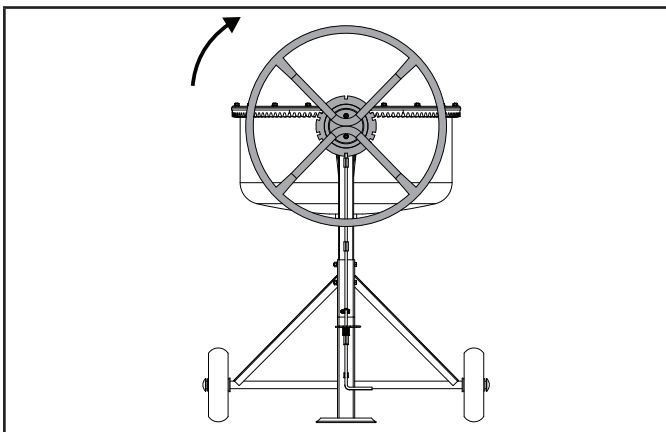

- The hardware for this step (flange nuts and bolts) are assembled to the bottom drum half. Using a 12mm socket or wrench, remove each flange nut and bolt from the bottom drum half and set them aside.



- Using the arrows on the top and bottom drum halves, align the top drum half with the bottom drum half and seat the top drum half onto the bolts in the bottom drum half.
- Ensure that the holes in the top drum half are completely seated on the protruding bolts.
- Thread a flange nut (removed in step 1) onto each protruding bolt and thread a flange bolt (removed in step 1) into each threaded hole around the base of the drum and hand tighten.
- Using a 12mm socket or wrench, securely tighten each nut and bolt.

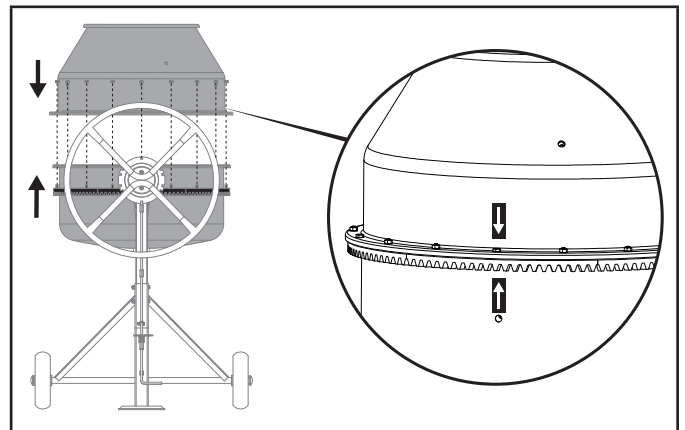

Assemble the Mixing Blades to the Drum

NOTICE

The mixing blades have an L shape on one end. This L shape will go to the bottom of the drum.

- Using the foot lever, release the drum lock and tip the drum a 1/4 turn to one side, insert a mixing blade, L shaped end (1) towards the bottom of the drum and align the mounting holes with the holes in the drum.

- From the outside of the drum, insert two (2) flat head, M12 x 25 bolts through the holes in the drum, then place a lock washer on each bolt and thread a M12 nut onto each bolt and hand tighten.
- Using a 19mm socket or wrench and the included butterfly wrench, securely tighten each set of nuts and bolts.
- Repeat these steps for the other mixing blade.

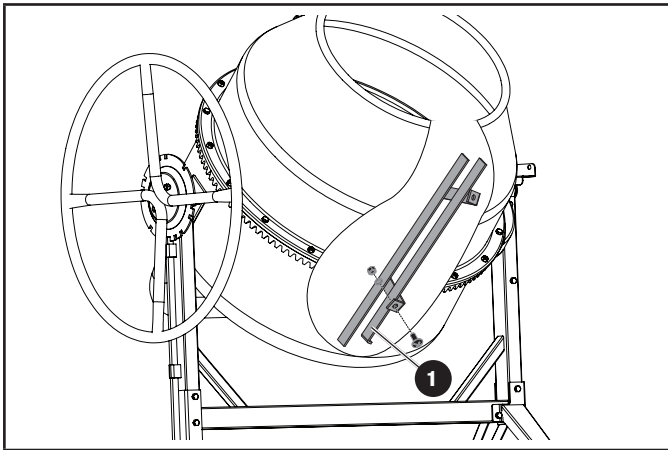

- Spin the drum until the foam tape on the drum gear teeth engage with the engine shaft gear holding the drum in place. This will ensure that the drum and engine shaft do not spin as you are mounting the engine on the engine shaft.

NOTICE

There is a guard covering the drive gear. You will not be able to see it as shown here. This is simply to clarify where the foam needs to engage the drive gear.

WARNING

NEVER remove any guards or safety devices.

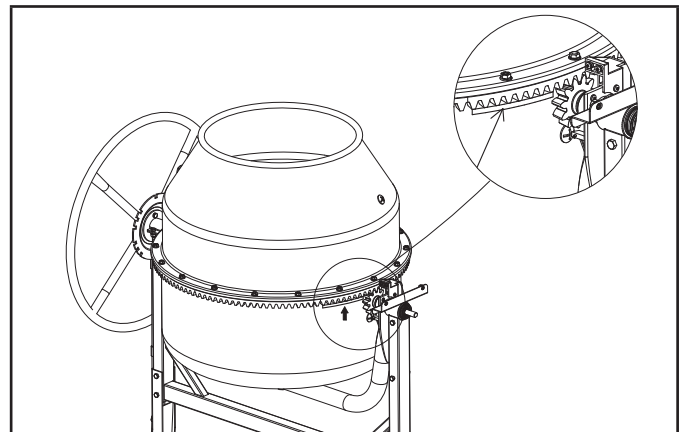

Assemble the Engine

NOTICE

This assembly requires 2 people.

NOTICE

Ensure that the engine drive shaft and receptacle on the back of the engine are free of any dirt and/or debris.

- With the drum in the upright position, place the adhesive backed engine mount foam piece up against the bottom of the drum gear teeth as shown.

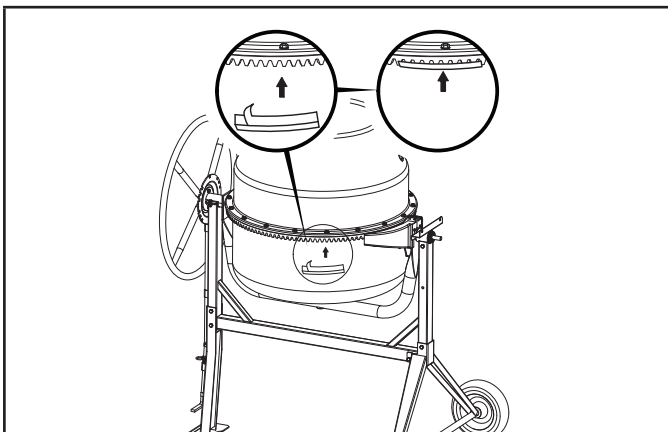

- Using 2 people (one on each side of the engine box) lift the engine up and align the receptacle on the back of the engine with the protruding drive shaft while also aligning the threaded studs on the engine box with the holes on the engine mounting bracket. Push inward until the engine is fully seated on the shaft and the studs are protruding through the holes on the mounting bracket.
- Place a flat washer and lock washer on each threaded stud, then thread a M8 nut onto each stud on the back of the engine box and hand tighten.
- Using a 14mm wrench or socket, securely tighten each nut. This will draw the engine in to fully seat on the shaft and against the mounting bracket.
- Put a M8 x 70 bolt through the bottom holes on the mounting bracket below the engine and U-frame, then place a flat washer and lock washer on the bolt. Thread a M8 nut onto the bolt and hand tighten.

- Using a 14mm socket and wrench, securely tighten the nut and bolt.

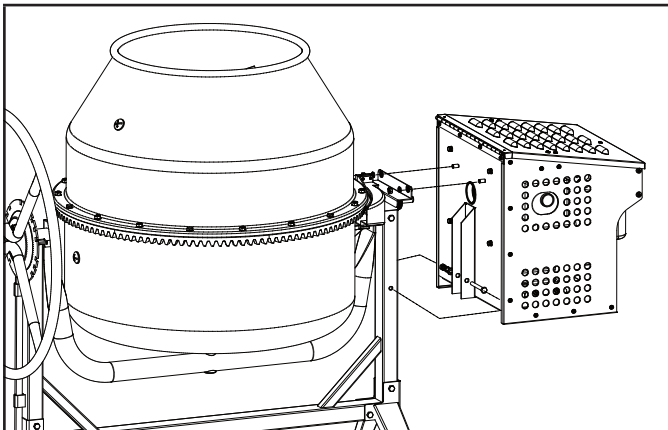

- Once the engine is mounted, gently pull the recoil start on the engine 5 to 6 times to expose the foam tape that is mounted to the drum gear teeth, then remove the foam tape. Your engine is now successfully mounted.

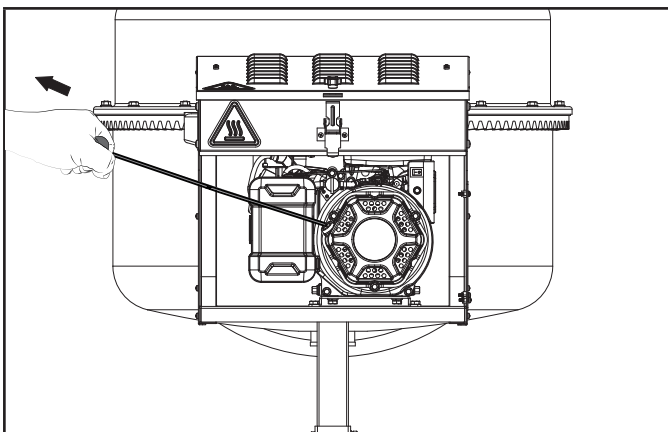

Add Engine Oil

⚠ WARNING

DO NOT attempt to crank or start the engine before it has been properly filled with the recommended type and amount of oil. Damage to the concrete mixer as a result of failing to follow these instructions will void your warranty.

🗨 NOTICE

The recommended oil type is **10W-30 automotive oil**.

🗨 NOTICE

Once oil has been added, a visual check should show oil about 1-2 threads from running out of the fill hole.

If using the dipstick to check oil level, DO NOT screw in the dipstick while checking.

🗨 NOTICE

Check oil often during the break-in period. Refer to the *Maintenance* section for recommended service intervals.

🗨 NOTICE

We consider the first 5 hours of run time to be the break-in period for the engine. During the break in period we recommend using standard automotive non-synthetic blended oils. After the break in period synthetic lubricant can be used but is not required. Adjusting throttle setting will increase/decrease engine speed helping to seat piston rings. Avoid bogging or lugging the engine down and avoid prolonged running at constant RPM.

🗨 NOTICE

Temperature will affect engine oil and engine performance. Change the type of engine oil used based on temperature shown in *Recommended Engine Oil Type* table.

🗨 NOTICE

Synthetic oil may be used after the 5 hour initial break-in period. Using synthetic oil does not decrease the recommended oil change interval. Full synthetic 5W-30 oil will aid in starting in cold ambient < 41°F (5°C).

Recommended Engine Oil Type	
°F	-20 0 20 40 60 80 100 120
°C	-28.9 -17.8 -6.7 4.4 15.6 26.7 37.8 48.9
Ambient temperature	

- Place the concrete mixer on a flat, level surface.
- Using a Philips head screwdriver, loosen the 4 screws on the oil fill access panel.

- Once all screws are loose, slide the panel upward and pull outward slightly. Allow the panel to drop and hang by the bottom left screw.

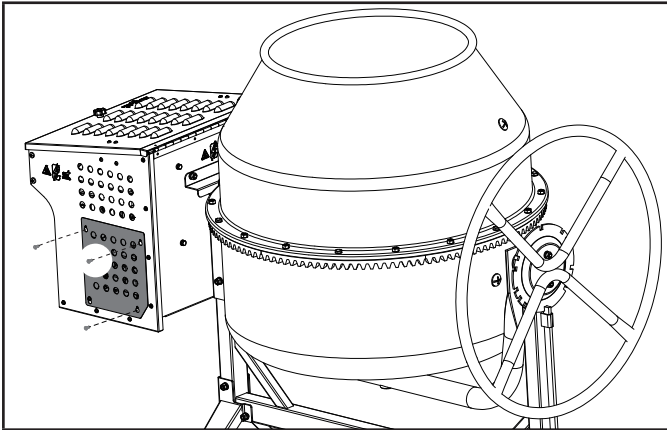

- Remove the oil fill cap/dipstick to add oil.
- Using a funnel, add up to 11.8 fl. oz. (350 ml) of oil (included) and replace the oil fill cap/dipstick. **DO NOT OVERFILL.**

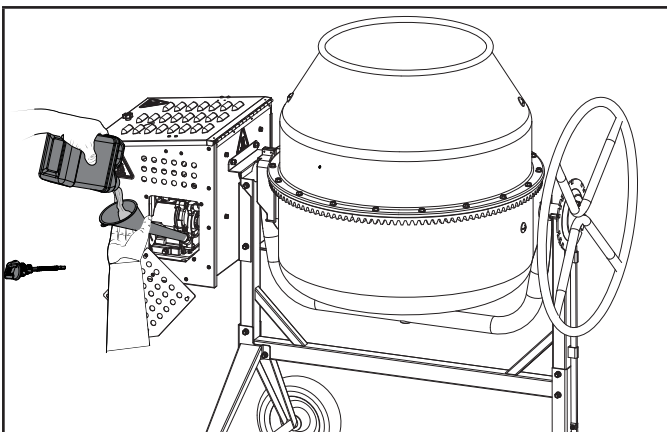

- Replace the access panel by rotating it upward and seating it back onto the screws. Securely tighten all screws to secure the panel in place.
- Check engine oil level daily and add as needed.

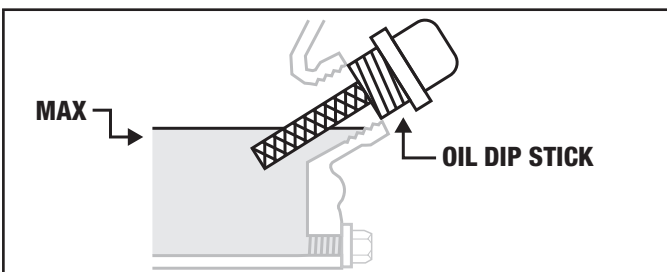

Add Fuel

⚠ WARNING

Pouring gasoline too fast through the fuel screen may result in blow back of gasoline at the operator while filling.

⚠ CAUTION

Use regular unleaded gasoline with a minimum octane rating of 87 and an ethanol content of less than 10% by volume.

DO NOT light cigarettes or smoke when filling the tank.

DO NOT mix oil and gasoline.

Fill tank to approximately ¼ in. (6.4 mm) below the top of the tank to allow for gasoline expansion.

DO NOT pump gasoline directly into the concrete mixer at the pump. Use an approved container to transfer the gasoline to the concrete mixer.

DO NOT fill tank indoors.

DO NOT fill tank when the engine is running or hot.



DO NOT overfill the tank.

🗨 NOTICE

Our engines work well with 10% or less ethanol blend gasoline. When using ethanol-gasoline blends there are some issues worth noting:

- Ethanol-gasoline blends can absorb more water than gasoline alone.
- These blends can eventually separate, leaving water or a watery goo in the tank, fuel valve and carburetor.
- With gravity-fed supplies, the compromised gasoline can be drawn into the carburetor and cause damage to the engine and/or potential hazards.
- There are only a few suppliers of fuel stabilizer that are formulated to work with ethanol-gasoline blends.
- Any damages or hazards caused by using improper gasoline, improperly stored gasoline, and/or improperly formulated stabilizers, are not covered by manufacturer's warranty.

It is advisable to always shut off the gasoline supply, run the engine to starvation and drain the tank when the equipment is not in use for more than 30 days.

- Use clean, fresh, regular unleaded gasoline with a minimum octane rating of 87 and an ethanol content of less than 10% by volume.   
- DO NOT mix oil with gasoline.

- Open the engine box cover.

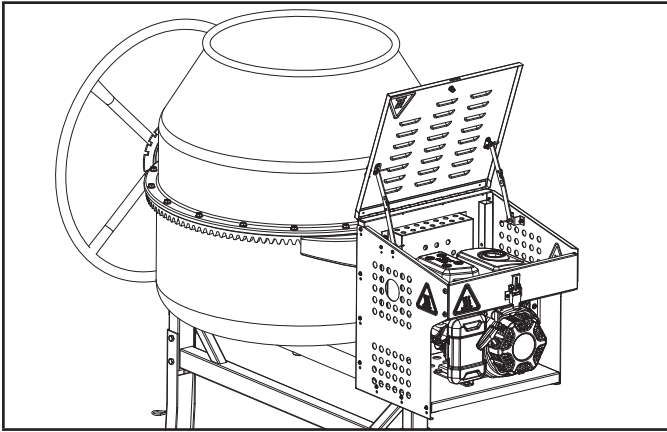

- Remove the gasoline cap.
- Using a funnel, slowly add gasoline to the tank. DO NOT OVERFILL.
- Gasoline can expand after filling. A minimum of $\frac{1}{4}$ in. (6.4 mm) of space left in the tank is required for gasoline expansion, although more than $\frac{1}{4}$ in. (6.4 mm) is recommended. Gasoline can be forced out of the tank as a result of expansion if overfilled, and can affect the stable running condition of the concrete mixer.
- Screw on the gasoline cap and wipe away any spilled fuel.

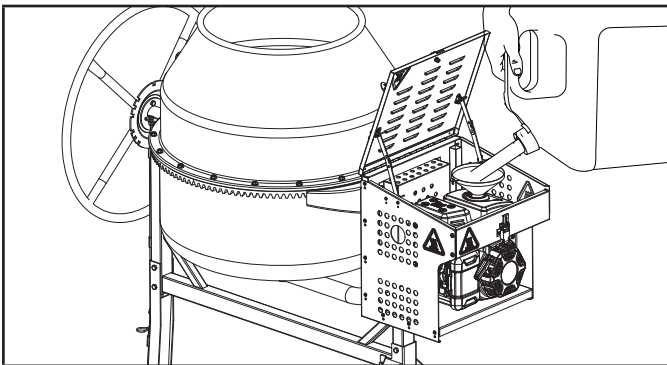

OPERATION

⚠ WARNING

ALWAYS use the mixer for its intended use. The mixer should only be used to mix and prepare mortar and concrete.

NEVER modify, alter or change the mixer in any way. Modifications will void warranty.

DO NOT modify or change the engine and operating speeds. These changes can cause safety issues.

ONLY operate the mixer in daylight.

NEVER operate or let anyone else operate the mixer while under the influence of alcohol, drugs or medication.

NEVER leave the mixer unattended while the engine is running.

Before Each Use Inspect the Mixer

- Inspect all parts for damage, cracks, loose fittings or other damage
- DO NOT operate the mixer if there is any indication of damage.

⚠ WARNING

Before operating your machine, carefully read and understand all safety, controls and operating instructions.

Failure to follow these instructions can result in serious personal injury.

Tipping Wheel

The tipping wheel with locking lugs allows for tipping control of the drum (see below) and can be locked in the following positions: Loading/Mixing - mortar, Loading/Mixing - concrete, Discharging, and Storage.

The drum is locked into the desired position by the lugs on the tipping wheel, which engage with the locking bar. To tip the drum, push down on the foot actuated locking lever to disengage the locking lugs. This allows the tipping wheel to turn the drum in the desired direction.

To lock the drum in position, release the foot lever when rotating the drum. The locking bar will slide into the nearest lug on the tilt wheel and lock into place.

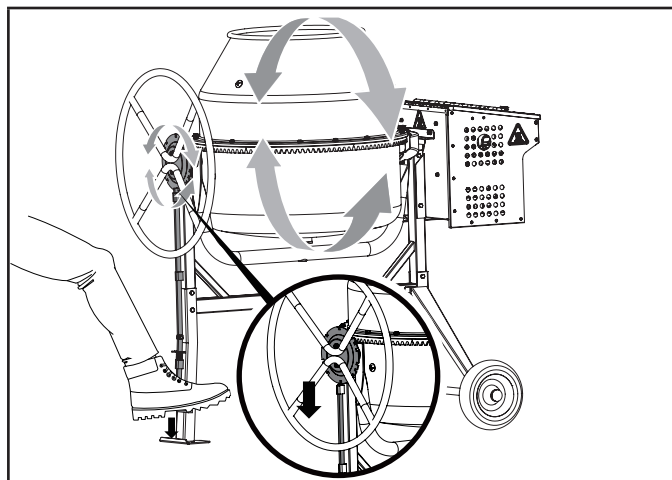

Loading and Mixing Positions

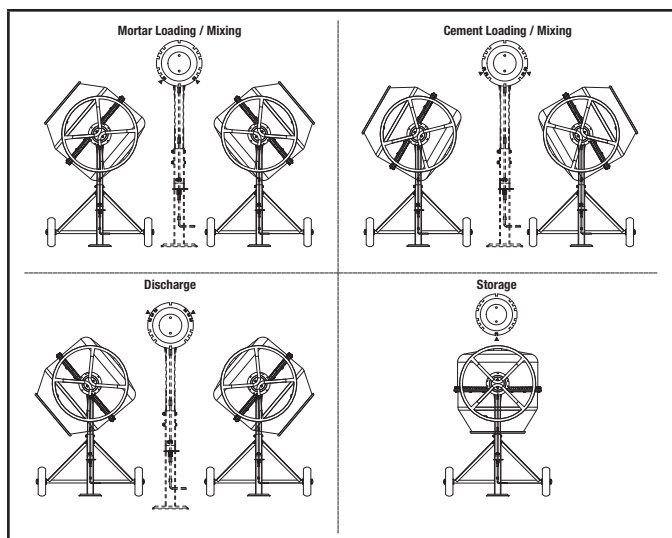

Starting the Engine

1. Make certain the mixer is on a flat, level surface.
2. Rotate the fuel valve to "ON" position.

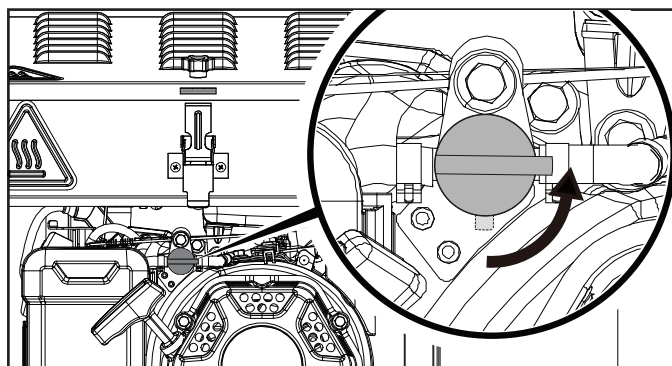

3. Move the choke lever to the "CHOKE" position.

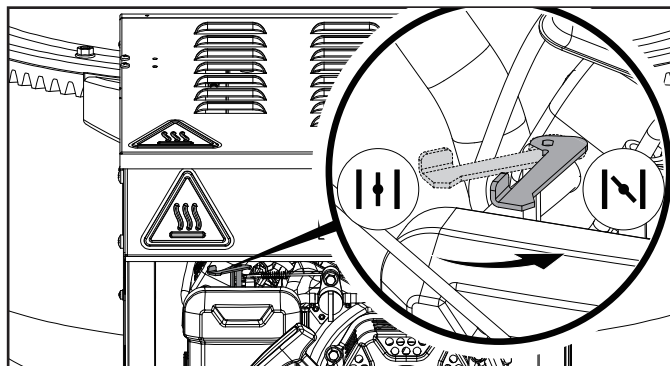

4. Move the throttle lever to the left to the full throttle position.

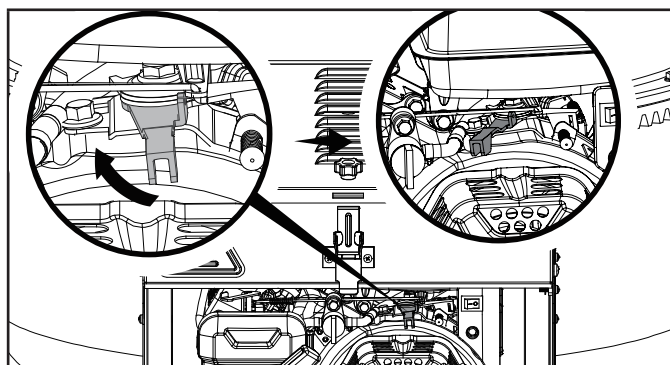

5. Pull the starter cord slowly until resistance is felt and then pull rapidly.

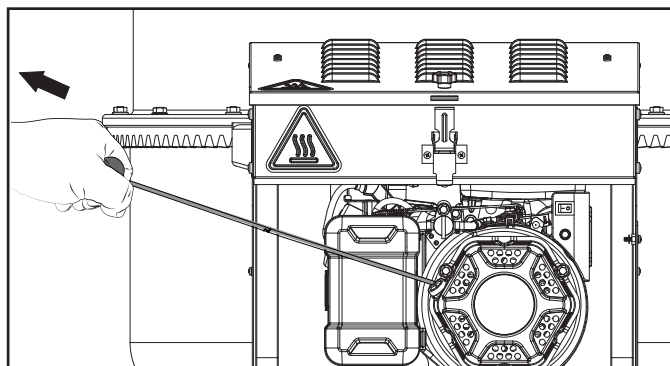

6. Keep choke lever in "CHOKE" position for 2 pulls of the recoil starter. After second pull, move choke lever to the "RUN" position for up to the next 3 pulls of the recoil starter. Too much choke leads to spark plug fouling/engine flooding due to the lack of incoming air. This will cause the engine to not start.

- As the engine warms up, move the choke lever to the "RUN" position.

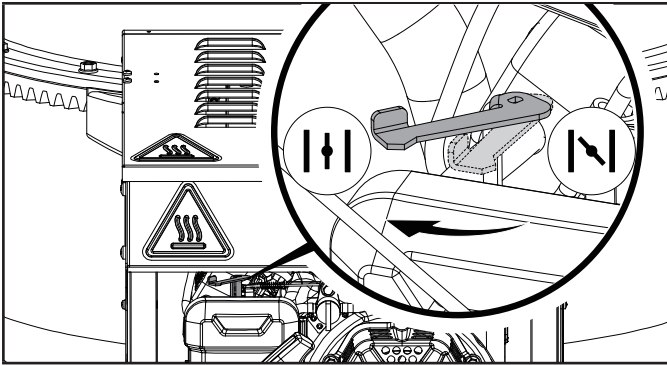

Stopping the Engine

In an emergency, turn the engine switch to the "OFF" position.

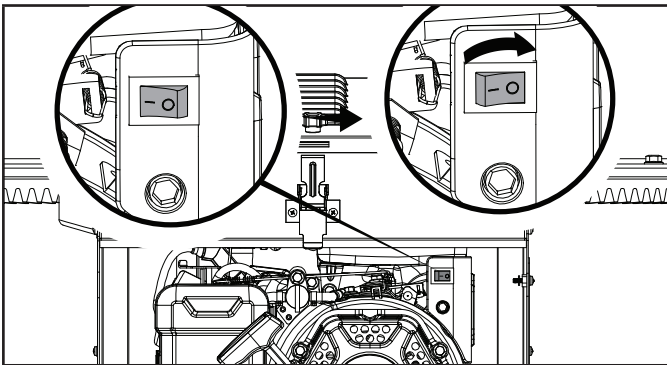

NOTICE

If the engine will not be used for a period of two (2) weeks or longer, please see the *Storage* section for proper engine and fuel storage.

Under Normal Conditions

- Turn the fuel valve to the "OFF" position.

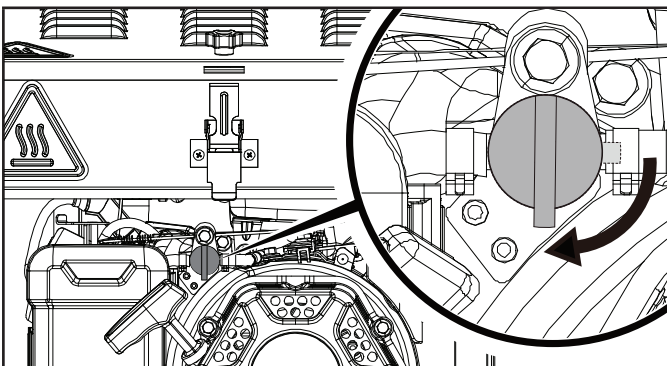

- Let the engine run until fuel starvation has stopped the engine. This usually takes a few minutes.

Loading the Mixer

NOTICE

Always start the engine before you start loading the drum. The mixer blades should be turning before you start adding the contents.

NOTICE

To avoid concrete or mortar sticking to the insides of the mixer drum, slowly pour material into the mixer steadily over the rim.

For best results, always load the mixer in the following order:

- Add the required amount of gravel into the drum.
- Add the required amount of cement into the drum.
- Add the required amount of sand into the drum.
- Pour the required amount of water into the drum.

NOTICE

Do not turn the mixer off (stop rotating) if you have content inside the drum. Always empty the drum completely with the mixer rotating.

MAINTENANCE

Make certain that the concrete mixer is kept clean and stored properly. Only operate the unit on a flat, level surface.

Inspect all air vents and cooling slots to ensure that they are clean and unobstructed.

Check and tighten all bolts and nuts before operating the concrete mixer.

WARNING

Never operate a damaged or defective mixer.

WARNING

Improper maintenance will void your warranty.

NOTICE

For Emission control devices and systems, read and understand your responsibilities for service as stated in the Emission Control Warranty Statement of this manual.

The owner/operator is responsible for all periodic maintenance.

Complete all scheduled maintenance in a timely manner.

Correct any issue before operating the concrete mixer.

For service or parts assistance, contact our Technical Support Team at 1-877-338-0999.

Cleaning the Mixer

⚠ WARNING

Never put hands or limbs inside the drum while the mixer is rotating.

⚠ CAUTION

DO NOT spray engine with water.

Water can contaminate the fuel system and can enter the engine through the cooling slots and damage the engine.

🗨 NOTICE

Wipe off any external material on the engine box.

Keep your mixer clean. Thoroughly clean the mixer at the end of each day's operation. The slightest trace of material left in the drum will harden and accumulate more each time you use it until the machine will no longer operate. Dried concrete should be scraped out of the drum. Do not throw bricks into mixer drum to clean it out. Do not beat on the drum with a shovel, a hammer or other tools to break up accumulations of dried concrete mix, as damage to the mixer may result. The drum may be scoured for approximately 2 minutes, using 1" gravel and water mixture. Then discharge the gravel/water mixture and hose down the drum assembly inside and out.

Check Hardware

Check for loose or missing hardware after every 10 operating hours and tighten or replace (as needed) before reusing the mixer.

Changing the Engine Oil

🗨 NOTICE

Once oil has been added, a visual check should show oil about 1-2 threads from running out of the fill hole. If using the dipstick to check oil level, DO NOT screw in the dipstick while checking.

🗨 NOTICE

Change oil when the engine is warm. Refer to the oil specification to select the proper grade for your operating environment.

1. Place the concrete mixer on a flat, level surface.

2. Using a Philips head screwdriver, loosen the 4 screws on the oil fill access panel.
3. Once all screws are loose, slide the panel upward and pull outward slightly. Allow the panel to drop and hang by the bottom left screw.

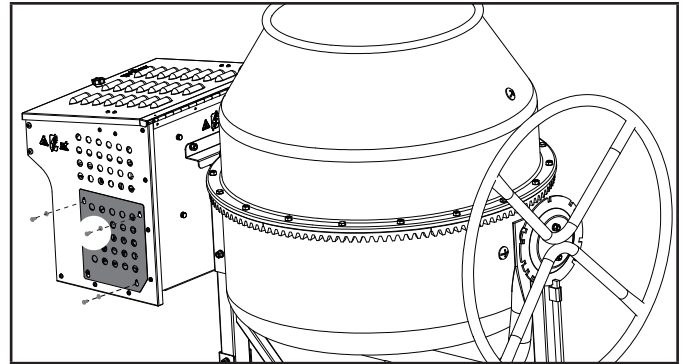

4. Remove the oil drain plug with a 10 mm socket.

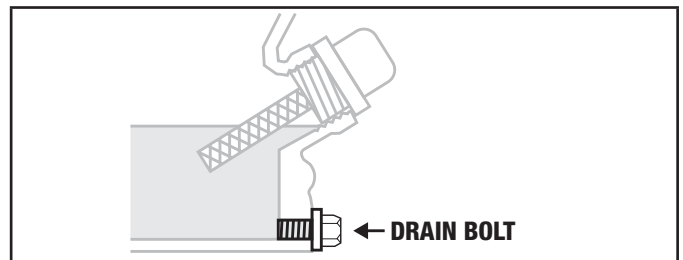

5. Allow the oil to drain completely into an appropriate container.
6. Replace the oil drain plug.
7. Remove the oil fill cap/dipstick to add oil.
8. Using a funnel, add up to 11.8 fl. oz. (350 ml) of oil (included) and replace oil fill cap/dipstick. DO NOT OVERFILL.

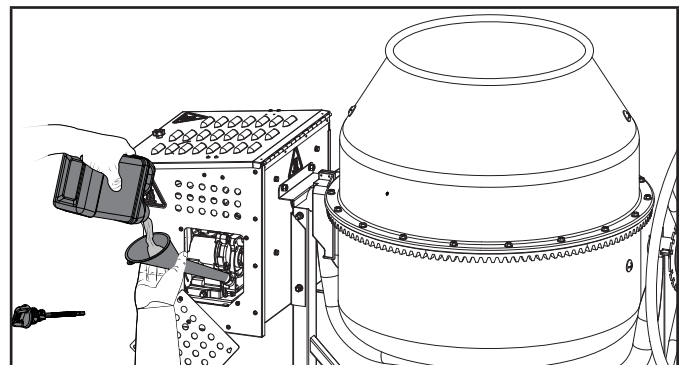

9. Dispose of used oil at an approved waste management facility.

Cleaning and Adjusting the Spark Plug(s)

1. Remove the spark plug cable from the spark plug.
2. Use a spark plug socket tool (included), or a 5/8 in. (16 mm) socket (not included) to remove the plug.

- Inspect the electrode on the plug. It must be clean and not worn to produce the spark required for ignition.
- Make certain the spark plug gap is 0.024-0.031 in. (0.6-0.8 mm).

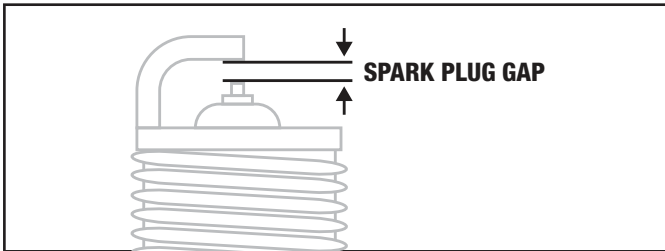

- Refer to the spark plug types in *Specifications* when replacing the plug.
- Firmly re-install the plug.
- Attach the spark plug cable to the spark plug.

Cleaning the Air Filter

- Remove the plastic cover by pressing the snap on the side of the cover.

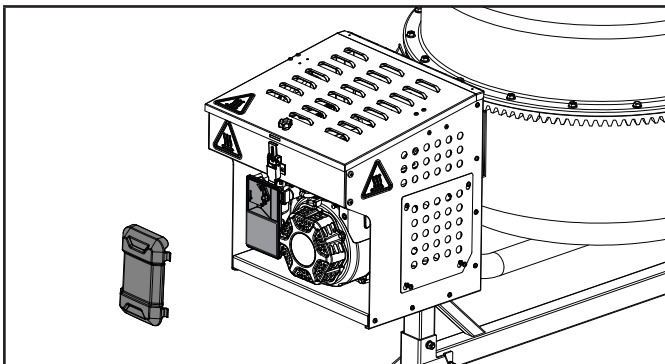

- Remove the foam element.

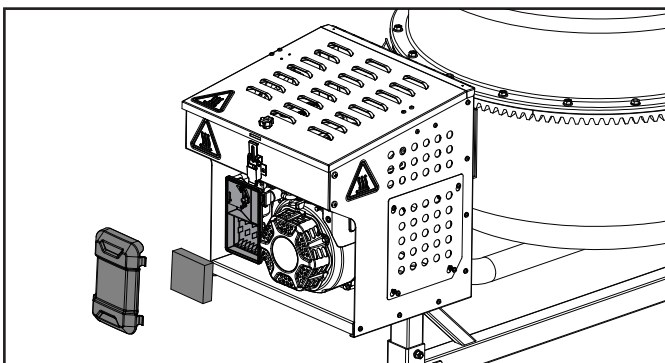

- Wash in liquid detergent and water. Squeeze thoroughly dry in a clean cloth.
- Saturate in clean engine oil.
- Squeeze in a clean, absorbent cloth to remove all excess oil.
- Place the filter in the assembly.

- Reattach the filter cover by inserting the tabs on the side closest to the fuel tank then pivot the other side into place. Ensure that the filter cover snaps into place.

Maintenance Schedule

Follow the service intervals indicated in the following maintenance schedule.

Service your concrete mixer more frequently when operating in adverse conditions.

Contact our Technical Support Team at 1-877-338-0999 to locate the nearest CPE certified service dealer for your concrete mixer or engine maintenance needs.

EVERY 8 HOURS OR DAILY

- Check engine oil levels
- Clean around air intake and muffler

FIRST 5 HOURS

- Change engine oil

EVERY 50 HOURS OR EVERY SEASON

- Clean air filter
- Change oil if operating under heavy load or in hot environments

EVERY 100 HOURS OR EVERY SEASON

- Change oil
- Clean/adjust spark plug*
- Clean/adjust valve clearance*
- Clean fuel tank and filter*

EVERY 250 HOURS

- Clean combustion chamber*

EVERY 3 YEARS

- Replace fuel line*

*To be performed by knowledgeable, experienced owners or CPE certified service centers.

STORAGE

Refer to the *Maintenance* section for proper cleaning instructions.

⚠ WARNING

Never store the concrete mixer indoors next to appliances where there is a source of heat or open flame, spark or pilot light because they can ignite gasoline vapors. Even with an empty gas tank, gasoline vapors could ignite.

DO NOT store a concrete mixer near fertilizer or any corrosive material.

Concrete Mixer Storage

1. The concrete mixer needs to be cool for at least 5 minutes before storing.
2. Clean the concrete mixer before storage according to the *Maintenance* section.

Engine Stored for Less than 30 Days

1. Allow the engine to cool completely before storage.
2. Clean engine according to the *Maintenance* section.
3. To extend the fuel storage life add a properly formulated fuel stabilizer to the tank.

Engines Stored for Over 30 Days

1. Add a properly formulated fuel stabilizer to the tank.
2. Run the engine for a few minutes so the treated fuel cycles through the fuel system and carburetor.
3. The engine needs to cool completely before cleaning and storage.
4. Clean the engine according to the *Maintenance* section.
5. Change the oil.
6. Remove the spark plug and pour about ½ oz (14.8 mL) of oil into the cylinder. Using the Recoil, crank the engine slowly to distribute the oil and lubricate the cylinder.
7. Reattach the spark plug.

SPECIFICATIONS

Concrete Mixer Specifications

Model	201495
Drum Cubic Feet	8.8
Drum Material	Steel
Weight Capacity	441 lb. (200 kg)
Number of Mixing Blades	2
Drum Opening Diameter	17.5 in. (44.5 cm)
Net Weight	192.9 lb. (87.5 kg)
Length	56.3 in. (143 cm)
Width	37 in. (94 cm)
Height	55.9 in. (142 cm)

Engine Specifications

Model	R80-VP
Displacement	79 cc
Type	4-Stroke OHV
Start Type	Manual

Engine Oil Specifications

DO NOT OVERFILL.

Type	*See Engine Oil chart
Capacity	11.8 fl. oz. (350 ml)

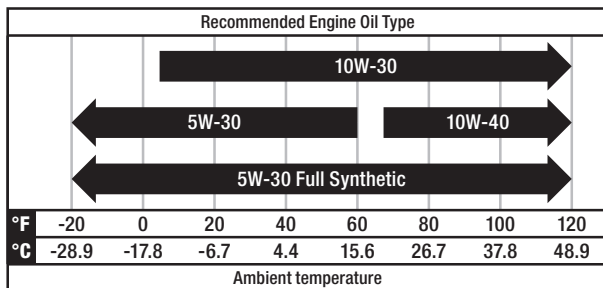

NOTICE

Temperature will affect engine oil and engine performance. Change the type of engine oil used based on temperature shown in the "Recommended Engine Oil Type" table.

Fuel Specifications

Use unleaded gasoline with a minimum octane rating of 87 and an ethanol content of 10% or less by volume. DO NOT USE E15 or E85. DO NOT OVERFILL.

Gasoline Capacity	0.3 gal. (1.29 L)
-------------------------	-------------------

Spark Plug Specifications

OEM Type	A5RTC
Replacement Type	CR5HSA or equivalent
Gap	0.024-0.031 in. (0.6-0.8 mm)

Valve Specifications

Intake Clearance	0.002-0.0059 in. (0.05-0.15 mm)
Exhaust Clearance	0.002-0.0059 in. (0.05-0.15 mm)

NOTICE

A technical bulletin regarding valve adjustment procedures is available at www.championpowerequipment.com.

NOTICE

An important message about temperature: Your product is designed and rated for continuous operation at ambient temperatures up to 104°F (40°C). When needed, it may be operated at temperatures ranging from 5°F (-15°C) to 122°F (50°C) for short periods of time. If exposed to temperatures outside this range during storage, it should be brought back within this range before operation. In any event, the product must always be operated outdoors, in a well-ventilated area and away from doors, windows and vents.

Regulatory Compliance

CAN ICES-002(B) / NMB-002(B)

Changes or modifications not expressly approved by Champion Power Equipment could void the user's authority to operate the equipment.

TROUBLESHOOTING

Problem	Cause	Solution
Engine will not start.	No fuel.	Add fuel.
	Faulty spark plug.	Replace spark plug.
	Unit loaded during start up.	Remove load from unit.
Engine will not start; Engine starts but runs roughly.	Low oil level.	Fill crankcase to the proper level.
		Place concrete mixer on a flat, level surface.
	Choke in the wrong position.	Adjust choke.
	Spark plug wire loose.	Attach wire to spark plug.
Engine shuts down during operation.	Out of fuel.	Fill fuel tank.
	Low oil level.	Fill crankcase to the proper level. Place concrete mixer on a flat, level surface.
Engine cannot supply enough power or overheating.	Insufficient ventilation.	Check for air restriction. Move to a well ventilated area.
Drum fails to rotate.	Debris in the drum teeth or drive gear.	Remove debris.
	Engine stops working.	See engine troubleshooting steps above.

For further technical support:

Technical Support Team
Toll Free 1-877-338-0999
support@championpowerequipment.com

WARRANTY*

CHAMPION POWER EQUIPMENT
2 YEAR LIMITED WARRANTY

Warranty Qualifications

To register your product for warranty and FREE lifetime call center technical support please visit:

<https://www.championpowerequipment.com/register>

To complete registration you will need to include a copy of the purchase receipt as proof of original purchase. Proof of purchase is required for warranty service. Please register within ten (10) days from date of purchase.

Repair/Replacement Warranty

CPE warrants to the original purchaser that the mechanical and electrical components will be free of defects in material and workmanship for a period of two years (parts and labor) from the original date of purchase and 180 days (parts and labor) for commercial and industrial use. Transportation charges on product submitted for repair or replacement under this warranty are the sole responsibility of the purchaser. This warranty only applies to the original purchaser and is not transferable.

Do Not Return The Unit To The Place Of Purchase

Contact CPE's Technical Service and CPE will troubleshoot any issue via phone or e-mail. If the problem is not corrected by this method, CPE will, at its option, authorize evaluation, repair or replacement of the defective part or component at a CPE Service Center. CPE will provide you with a case number for warranty service. Please keep it for future reference. Repairs or replacements without prior authorization, or at an unauthorized repair facility, will not be covered by this warranty.

Warranty Exclusions

This warranty does not cover the following repairs and equipment:

Normal Wear

Products with mechanical and electrical components need periodic parts and service to perform well. This warranty does not cover repair when normal use has exhausted the life of a part or the equipment.

Installation, Use and Maintenance

This warranty will not apply to parts and/or labor if the product is deemed to have been misused, neglected, involved in an accident, abused, loaded beyond the product's limits, modified, installed improperly or connected incorrectly to any electrical component. Normal maintenance is not covered by this warranty and is not required to be performed at a facility or by a person authorized by CPE.

Other Exclusions

This warranty excludes:

- Cosmetic defects such as paint, decals, etc.
- Wear items such as filter elements, o-rings, etc.
- Accessory parts such as hoses, storage covers, etc.
- Failures due to acts of God and other force majeure events beyond the manufacturer's control.
- Problems caused by parts that are not original Champion Power Equipment parts.

Limits of Implied Warranty and Consequential Damage

Champion Power Equipment disclaims any obligation to cover any loss of time, use of this product, freight, or any incidental or consequential claim by anyone from using this product. THIS WARRANTY AND THE ATTACHED U.S. EPA and/or CARB EMISSION CONTROL SYSTEM WARRANTIES (WHEN APPLICABLE) ARE IN LIEU OF ALL OTHER WARRANTIES, EXPRESS OR IMPLIED, INCLUDING WARRANTIES OF MERCHANTABILITY OR FITNESS FOR A PARTICULAR PURPOSE.

This warranty gives you certain legal rights which may change from state to state or province to province. Your state or province may also have other rights you may be entitled to that are not listed within this warranty.

Contact Information

Address

Champion Power Equipment, Inc.
6370 S Pioneer Way, Unit 101
Las Vegas, NV 89113 USA
www.championpowerequipment.com

Customer Service

Toll Free: 1-877-338-0999
info@championpowerequipment.com
Fax no.: 1-562-236-9429

Technical Service

Toll Free: 1-877-338-0999
tech@championpowerequipment.com

📞 EMERGENCY 24 HOUR SUPPORT: 1-562-204-1188

*Except as otherwise stipulated in any of the following enclosed Emission Control System Warranties (when applicable) for the Emission Control System: U.S. Environment Protection Agency (EPA) and/or California Air Resources Board (CARB).

**CHAMPION POWER EQUIPMENT, INC. (CPE)
AND THE UNITED STATES ENVIRONMENTAL PROTECTION AGENCY (U.S. EPA)
EMISSION CONTROL SYSTEM WARRANTY**

Your Champion Power Equipment (CPE) engine complies with U.S. EPA emissions regulations.

YOUR WARRANTY RIGHTS AND OBLIGATIONS:

The US EPA and CPE are pleased to explain the Federal Emission Control Systems Warranty on your 2026 small off-road engine and engine powered equipment. New engines and equipment must be designed, built and equipped, at the time of sale, to meet U.S. EPA regulations for small off-road engines. CPE warrants the emission control system on your small off-road engine and equipment for the period of time listed below, provided there has been no abuse, neglect, unapproved modification, or improper maintenance of your equipment.

Your emission control system may include parts such as the carburetor, fuel-injection system, the ignition system, catalytic converter and fuel lines. Also included may be hoses, belts, connectors and other emission related assemblies. Where a warrantable condition exists, CPE will repair your small off-road engine at no cost to you including diagnosis, parts and labor.

MANUFACTURER'S EMISSION CONTROL SYSTEM WARRANTY COVERAGE:

This emission control system is warranted for two years, subject to provisions set forth below. If, during the warranty period, an emission related part on your engine is defective in materials or workmanship, the part will be repaired or replaced by CPE.

OWNER'S WARRANTY RESPONSIBILITIES:

As the small off-road engine owner, you are responsible for the performance of the required maintenance listed in your Owner's Manual. CPE recommends that you retain all your receipts covering maintenance on your small off-road engine, but CPE cannot deny warranty solely for the lack of receipts or for your failure to ensure the performance of all scheduled maintenance.

As the small off-road engine owner, you should however be aware that CPE may deny you warranty coverage if your small, off-road engine or a part has failed due to abuse, neglect, improper maintenance or unapproved modifications.

You are responsible for presenting your small off-road engine to an Authorized CPE service outlet or alternate service outlet as described in (3)(f.) below, CPE dealer or CPE, Las Vegas, NV. as soon as a problem exists. The warranty repairs should be completed in a reasonable amount of time, not to exceed 30 days.

If you have any questions regarding your warranty rights and responsibilities, you should contact:

Champion Power Equipment, Inc.
Customer Service
6370 S Pioneer Way, Unit 101
Las Vegas, NV 89113
1-877-338-0999
tech@championpowerequipment.com

EMISSION CONTROL SYSTEM WARRANTY

The following are specific provisions relative to your Emission Control System (ECS) Warranty Coverage.

- 1. APPLICABILITY:** This warranty shall apply to 1997 and later model year small off-road engines. The ECS Warranty Period shall begin on the date the new engine or equipment is delivered to its original, end-use purchaser, and shall continue for 24 consecutive months thereafter.
- 2. GENERAL EMISSIONS WARRANTY COVERAGE**

CPE warrants to the original, end-use purchaser of the new engine or equipment and to each subsequent purchaser that the ECS when installed is:

 - 2a. Designed, built and equipped so as to conform to U.S. EPA emissions standards for spark-ignited engines at or below 19 kilowatts.
 - 2b. Free from defects in materials and workmanship that cause the failure of a warranted part to be identical in all material respects to the part as described in the engine manufacturer's application for certification for a period of two years.
- 3. THE WARRANTY ON EMISSION-RELATED PARTS WILL BE INTERPRETED AS FOLLOWS:**
 - 3a. Any warranted part that is not scheduled for replacement as required maintenance in the Operator's Manual shall be warranted for the ECS Warranty Period. If any such part fails during the ECS Warranty Period, it shall be repaired or replaced by CPE according to Subsection "d" below. Any such part repaired or replaced under the ECS Warranty shall be warranted for any remainder of the ECS Warranty Period.
 - 3b. Any warranted, emissions-related part which is scheduled only for regular inspection as specified in the Operator's Manual shall be warranted for the ECS Warranty Period. A statement in such written instructions to the effect of "repair or replace as necessary", shall not reduce the ECS Warranty Period. Any such part repaired or replaced under the ECS Warranty shall be warranted for the remainder of the ECS Warranty Period.
 - 3c. Any warranted, emissions-related part which is scheduled for replacement as required maintenance in the Operator's Manual shall be warranted for the period of time prior to the first scheduled replacement point for that part. If the part fails prior to the first scheduled replacement, the part shall be repaired or replaced by CPE according to Subsection "d" below. Any such emissions-related part repaired or replaced under the ECS Warranty, shall be warranted for the remainder of the ECS Warranty Period prior to the first scheduled replacement point for such emissions-related part.
 - 3d. Repair or replacement of any warranted, emissions-related part under this ECS Warranty shall be performed at no charge to the owner at a CPE Authorized Service Outlet.
 - 3e. The owner shall not be charged for diagnostic labor which leads to the determination that a part covered by the ECS Warranty is in fact defective, provided that such diagnostic work is performed at a CPE Authorized Service Outlet.
 - 3f. CPE shall pay for covered emissions warranty repairs at non-authorized service outlets under the following circumstances:
 - i. The service is required in a population center with a population over 100,000 according to U.S. Census 2000 without a CPE Authorized Service Outlet AND
 - ii. The service is required more than 100 miles from a CPE Authorized Service Outlet. The 100 mile limitation does not apply in the following states: Alaska, Arizona, Colorado, Hawaii, Idaho, Montana, Nebraska, Nevada, New Mexico, Oregon, Texas, Utah and Wyoming.
 - 3g. CPE shall be liable for damages to other original engine components or approved modifications proximately caused by a failure under warranty of an emission-related part covered by the ECS Warranty.
 - 3h. Throughout the ECS Warranty Period, CPE shall maintain a supply of warranted emission-related parts sufficient to meet the expected demand for such emission-related parts.
 - 3i. Any CPE Authorized and approved emission-related replacement part may be used in the performance of any ECS Warranty maintenance or repair and will be provided without charge to the owner. Such use shall not reduce CPE's warranty obligation.
 - 3j. Unapproved add-on or modified parts may not be used to modify or repair a CPE engine. Such use voids this ECS Warranty and shall be sufficient grounds for disallowing an ECS Warranty claim. CPE shall not be liable hereunder for failures of any warranted parts of a CPE engine caused by the use of such an unapproved add-on or modified part.

EMISSION-RELATED PARTS INCLUDE THE FOLLOWING: (using those portions of the list applicable to the engine)

Systems covered by this warranty	Parts Description
Fuel Metering System	Fuel regulator, Carburetor and internal parts
Air Induction System	Air cleaner, Intake manifold
Ignition System	Spark plug and parts, Magneto ignition system
Exhaust System	Exhaust manifold, catalytic converter
Miscellaneous Parts	Tubing, Fittings, Seals, Gaskets, and Clamps associated with these listed systems.
Evaporative Emissions	Fuel Tank, Fuel Cap, Fuel Lines (for liquid fuel and fuel vapors), Fuel Line Fittings, Clamps, Pressure Relief Valves, Control Valves, Control Solenoids, Electronic Controls, Vacuum Control Diaphragms, Control Cables, Control Linkages, Purge Valves, Gaskets, Liquid/Vapor Separator, Carbon Canister, Canister Mounting Brackets, Carburetor Purge Port Connector

TO OBTAIN WARRANTY SERVICE:

You must take your CPE engine or the product on which it is installed, along with your warranty registration card or other proof of original purchase date, at your expense, to any Champion Power Equipment dealer who is authorized by Champion Power Equipment, Inc. to sell and service that CPE product during his normal business hours. Alternate service locations defined in Section (3)(f.) above must be approved by CPE prior to service. Claims for repair or adjustment found to be caused solely by defects in material or workmanship will not be denied because the engine was not properly maintained and used.

If you have any questions regarding your warranty rights and responsibilities, or to obtain warranty service, please write or call Customer Service at Champion Power Equipment, Inc.

Champion Power Equipment, Inc.
6370 S Pioneer Way, Unit 101
Las Vegas, NV 89113
1-877-338-0999
Attn.: Customer Service
tech@championpowerequipment.com